



Université d'Oran 2

Institut de Maintenance et de Sécurité
Industrielle

THÈSE

Pour l'obtention du diplôme de Doctorat « L.M.D » En hygiène et
sécurité industrielle

**La sûreté de fonctionnement dans l'ingénierie des
systèmes complexes**

Présentée et soutenue publiquement

par :

Chakrit ammar

Le 21-06-2022

Devant le jury composé de :

LOUNIS ZOUBIDA	Professeur	Université d'Oran 2	Président
CHENNOUFI MOHAMMED	Maître de conférences A	Université d'Oran 2	Encadreur
AISSANI NASSIMA	Maître de conférences A	Université d'Oran 2	Examinatrice
HASSINI ABDELATIF	Professeur	Université d'Oran 2	Examineur
BOUAMRANE KARIM	Professeur	Université d'Oran 1	Examineur
CHAKER KADER	Professeur	Ecole National Polytechnique	Examineur

Année 2021/2022

Table des matières

Figures table

List of tables

Acknowledgement

Introduction General

1. Problematic	1
2. Objectives of the thesis	1
3. The contribution	2
4. General plan of the thesis	3

Chapter I: Literature review on analysis by dependability

1.1. INTRODUCTION	5
1.2. Dependability of system	5
1.2.1. Definition of dependability	6
1.2.2. Components of the dependability	6
1.2.2.1. Reliability $R(t)$	6
1.2.2.2. Availability $A(t)$	7
1.2.2.3. Safety	7
1.2.2.4. Maintainability	7
1.2.3. The Means to Attain Dependability	7
1.3. Concept of System	8
1.3.1. System definition	8
1.3.2. Complexity	9
1.3.3. Features of complex systems	9
1.3.3.1. Emergence	9
1.3.3.2. Nonlinearity	10
1.3.3.3. Hierarchical organization	10
1.3.3.4. Robustness and lack of central control	10

1.4. Systems engineering	11
1.4.1. Life cycle and development cycle.....	11
1.4.2. Exigencies engineering	12
1.4.2.1. Definition of an exigency.....	12
1.4.2.2. Role and interest of exigencies engineering.....	12
1.4.2.3. Expression of exigencies.....	13
1.4.2.4. Traceability	13
1.4.2.5. Change of requirements	14
1.5. Risk management	14
1.5.1. Definition of a risk	15
1.5.2. Why be interested in risks	16
1.6. Description of risk analysis methods.....	16
1.6.1. Qualitative / Quantitative	16
1.6.1.1. Qualitative methods	16
1.6.1.2. Quantitative methods	16
1.6.2. Statics / dynamics.....	17
1.6.2.1. Static methods	17
1.6.2.2. Dynamic methods.....	17
1.7. Dysfunctional analysis and assessment	18
1.7.1. FMEA / FMECA.....	18
1.7.2. Fault Tree Analysis	19
1.7.2.1. Fault Tree Construction.....	19
1.7.2.2. Construction Guidelines.....	20
1.7.3. Event Tree Analysis	23
1.7.3.1. Event tree methodology	24
1.7.4. Petri Net Analysis	25
1.7.5. Markov Analysis	26
1.8. Limitation of risk analysis methods.....	28
1.9. Criteria for choosing a risk analysis method	30

1.10. Conclusion.....	31
Chapter II: Criticality evaluation in FMECA method of the industrial risks	
2.1. INTRODUCTION.....	35
2.2. Multi-criteria decision making approaches (MCDM).....	35
2.2.1. Pairwise comparison methods.....	35
2.2.1.1. The analytic hierarchy process (AHP).....	36
2.2.1.1.1 Steps to Conduct AHP.....	36
2.2.1.1.2. Fuzzy Analytic Hierarchy Process.....	39
2.2.2. Distance-based methods (the grey relational analysis (GRA)).....	40
2.2.2.1 The main procedure of the grey relational analysis.....	40
2.2.2.1.1 Recognizing Comparative Series.....	40
2.2.2.1.2. Standard series identification.....	41
2.2.2.1.3. Obtain the difference between comparative and standard series.....	41
2.2.2.1.4. Compute the Grey Relationship Coefficient.....	41
2.2.2.1.5. Integrate the weighted factors to determine the degree of relation.....	41
2.2.2.1.6. Priority Ranking.....	42
2.3. Artificial intelligence approaches.....	42
2.3.1. Fuzzy LOGIC.....	42
2.3.1.1 Basic Definitions and Terminology.....	42
2.3.1.2 Membership Functions (MF).....	43
2.3.1.2.1. Triangular Membership Function.....	44
2.3.1.2.2. Trapezoidal Membership Function.....	44
2.3.1.2.3. Gaussian Membership Function.....	44
2.3.1.2.4. Generalized Bell Membership Function.....	44
2.3.1.2.5. Sigmoid Membership Function.....	45
2.3.1.3. Linguistic Variables and Fuzzy If-Then Rules.....	45
2.3.1.4. Fuzzy Inference Process.....	45
2.3.1.4.1. Fuzzification.....	46
2.3.1.4.2. Apply Fuzzy Operator.....	46

2.3.1.4.3 Apply Implication Method.....	47
2.3.1.4.4. Aggregate All Outputs	47
2.3.1.4.5. defuzzification.....	48
2.3.1.5. Why Use Fuzzy Logic.....	49
2.3.2. Development of the ANFIS Model and the structure	50
2.3.2.1.ANFIS architecture	50
2.3.2.2. ANFIS Process	52
2.3.2.2.1. Data collection	53
2.3.2.2.2. Training Data	53
2.3.2.2.2.1. Generating FIS Structure.....	53
2.3.2.2.2.2. Training Error.....	54
2.3.2.2.3. Checking Data.....	54
2.3.2.2.3.1. Checking Error	55
2.4. Conclusion	55

Chapter III: Traditional methodology of risk assessment in FMECA

3.1. INTRODUCTION.....	59
3.2. LPG storage system.....	59
3.2.1. What is LPG?	59
3.2.2. Properties of LPG.....	60
3.2.2.1. Vapour pressure	60
3.2.2.2. Specific weight of liquid	60
3.2.2.3. Specific weight of vapour.	60
3.2.2.4. Calorific power.....	60
3.2.3. Uses of LPG	60
3.3. Identification of the systems to be studied	61
3.3.1. LPG Storage zone	61
3.3.2. Phenomena observed.....	62
3.3.3. The severity of accidents.....	62
3.3.3.1. The causes of accidents.....	63

3.3.3.2. Important safety elements	64
3.4. Traditional FMECA method for criticality evaluation (case study I)	64
3.5. Gas turbine.....	66
3.5.1. Gas Turbine Categories.....	67
3.5.1.1. Aeronautical Gas Turbine	67
3.5.1.2. Electrical Power Generation	67
3.5.2. Gas Turbine Configurations	67
3.5.3. Working Principle of a Gas Turbine	68
3.5.4. Common Failures in Gas Turbine System	70
3.5.4.1. Vibration	71
3.5.4.2. Over temperature.....	71
3.5.4.3. Over-speed	72
3.5.4.4. Stall	72
3.5.4.5. Flame Out.....	72
3.5.4.6. Flame Leakage	72
3.5.4.7. Hot Spot on Flame Tube	72
3.5.4.8. Erosion	73
3.5.4.9. Corrosion.....	73
3.6. Traditional FMECA method for criticality evaluation (Gas turbine)	73
3.7. CONCLUSION	75
Chapter IV: Risk evaluation approaches in failure mode and effects analysis	
4.1. Introduction	78
4.2. Application of the proposed methodology to the LPG storage system	79
4.2.1. Quantification of the various input parameters (Step 1)	82
4.2.2. Fuzzy system Application to evaluate the five partial criticalities (Step 2).....	84
4.2.3. Application of the AHP method to evaluate the overall criticality and improving the decision-making (Step 3)	88
Results analysis	93
4.3. Application of the proposed methodology to the gas turbine system.....	94

4.3.1. Failure mode analysis by fuzzy methodology.....	95
4.3.2. Failure mode analysis by an adaptive neural fuzzy inference system	98
4.3.3. Failure mode analysis by Proposed Grey modeling.....	102
4.3.3.1. Recognizing Comparative Series	102
4.3.3.2. Standard series identification	102
4.3.3.4. Obtain the difference between comparative and standard series	102
4.3.3.4. Compute the Grey Relationship Coefficient	102
4.3.3.5. Integrate the weighted factors to determine the degree of relation.....	102
4.3.3.5. 1.Fuzzy Analytic Hierarchy Process	102
Results and discussion.....	107
4.4. Conclusion.....	108
GENERAL CONCLUSION.....	110

Figures table

FIGURE 1.1 RELIABILITY DECREASES OVER TIME	7
FIGURE 1.2 DIFFERENCE BETWEEN COMPLICATED SYSTEM AND COMPLEX SYSTEM	9
FIGURE 1.3 RISK CRITICALITY	15
FIGURE 1.4 EXAMPLE OF A FAULT TREE STRUCTURE.....	21
FIGURE 1.5 FLOW CHART FOR THE SEQUENTIAL PROCEDURE OF FMEA ANALYSIS	23
FIGURE 1.6 EVENT TREE DIAGRAM EXAMPLE.....	25
FIGURE 1.7 EXAMPLE OF A PETRI NET	26
FIGURE 1.8 EXAMPLE OF A MARKOV GRAPH.....	27
FIGURE 2.1 HIERARCHY STRUCTURE OF THE AHP METHOD	37
FIGURE 2.2 FUZZY TRIANGULAR MEMBERSHIP FUNCTIONS	39
FIGURE 2.3 INFERENCE SYSTEMS PROCESS	46
FIGURE 2.4 FUZZY OPERATOR EXAMPLE	47
FIGURE 2.5 GLOBAL FUZZY INFERENCE PROCESS	49
FIGURE 2.6 ANFIS ARCHITECTURE	52
FIGURE 2.7 THE FLOWCHART OF THE ANFIS	53
FIGURE 3.1 LPG SPHERE DESIGN	62
FIGURE 3.2 CAUSES OF INJURY OR DEATH[85]	63
FIGURE 3.3 BREAKDOWN BY TYPE OF CAUSE-CIRCUMSTANCE.....	63
FIGURE 3.4 GAS TURBINE DESIGN[86].....	67
FIGURE 3.5 THE SCHEMATIC OF SIMPLE CYCLE GAS TURBINE POWER GENERATOR	68
FIGURE 3.6 THE SCHEMATIC OF COMBINED CYCLE POWER GENERATOR	68
FIGURE 3.7 FUNCTIONAL TREE OF GAS TURBINE.....	70
Figure 4.1 Flow chart of the proposed approach.....	81
Figure 4.2 Fault tree analysis for “loss of containment in the LPG system”	83
Figure 4.3 Membership functions generated for (a) (F), (b) (S) and, (c) (ND)	86
Figure 4.4 Fuzzy inference process: case of criticality on equipment.....	87
Figure 4.5 Performance sensitivity graph.....	91
Figure 4.6 Gradient sensitivity graph for equipment.....	92
Figure 4.7 Gradient sensitivity graph for personnel.....	92
Figure 4.8 Membership functions generated for, probability, Severity and non-detection	96
Figure 4.9 Membership functions of output variable “criticality”	96
Figure 4.10 training data.....	99
Figure 4.11 checking data.....	99
Figure 4.12 Training and checking data errors for the ANFIS model.....	100
Figure 4.13 Flow chart of the proposed approach.....	103

List of Tables

TABLE 1.1 PRIMARY DEPENDABILITY ANALYSIS TECHNIQUES IEC-60300-3-1	17
TABLE 1.2 TRADITIONAL FAULT TREE EVENT SYMBOLS	21
TABLE 1.3 THE ADVANTAGES AND LIMITATIONS OF THE ANALYTICAL.....	28
TABLE 2.1 AHP COMPARISON SCALE.....	37
TABLE 3.1 PHENOMENA USED AS A BASIS FOR CLASSIFYING ACCIDENTS.....	62
TABLE 3.2 SEVERITY RATING	64
TABLE 3.3 FREQUENCY RATING	64
TABLE 3.4 NON-DETECTION RATING.....	65
TABLE 3.5 FMECA OF THE LPG SPHERE SYSTEM	65
TABLE 3.6 FAILURE MODES OF GAS TURBINE SYSTEM	71
TABLE 3.7 CONVENTIONAL FMECA RESULTS	73
TABLE 4.1 DATA OF LPG SYSTEM COMPONENTS FROM OREDA.....	84
TABLE 4.2 DATA COLLECTION TABLE FOR CRITICALITY CALCULATION	84
TABLE 4.3 CRITICALITIES OBTAINED FROM FUZZY INFERENCE ENGINES.....	88
TABLE 4.4 COMPARISON MATRIX FOR CRITERIA	88
TABLE 4.5 THE ARITHMETIC PRIORITY OF JUDGMENTS.....	88
TABLE 4.6 CRITICALITY WEIGHTS FACTORS.....	89
TABLE 5.7 COMPARISON MATRIX FOR ALTERNATIVES VERSUS CRITERIA	90
TABLE 4.8 GLOBAL PRIORITY VECTOR FOR DIFFERENT TYPES OF DECISIONS	91
TABLE 4.9 CONVENTIONAL FMECA AND FUZZY RPN RESULTS.....	97
TABLE 4.10 NEURO-FUZZY RPN RESULTS	100
TABLE 4.11 FUZZY PAIR WISE COMPARISONS TO CALCULATE WEIGHTS.....	105
TABLE 4.12 RANKING COMPARISON BETWEEN CONVENTIONAL, FUZZY, ANFIS AND GRA PROPOSED APPROACH	106

السلامة التشغيلية في هندسة النظم المعقدة

الملخص :

إن تكامل التقنيات المختلفة في هذا العالم الذي يتطور يوماً بعد يوم يؤدي إلى أنظمة مصممة أكثر تعقيداً مع سلوكيات يصعب التنبؤ بها . يعتبر تقييم أداء الأنظمة الصناعية ، من البسيط إلى المعقد ، عنصراً أساسياً في إدارة الشركات والسلامة التشغيلية . يصف هذا الأخير ويحلل الآليات التي تؤدي إلى الحوادث وإخفاقات النظام . طورت الشركات والمؤسسات العديد من طرق البحث لتجنب أو منع هذه الأحداث غير المتوقعة . يتم استخدام طريقة تحليل أنماط الفشل و آثارها وخطورتها بشكل شائع كأسلوب تحليلي موثوق به بشكل استباقي لتحديد وتصنيف وتقليل هذه الإخفاقات . ومع ذلك ، في كثير من الحالات ، فإنه يعاني من بعض أوجه القصور فيما يتعلق بعملية صنع القرار والوضع الذي تكون فيه المعلومات المقدمة غامضة أو غير مؤكدة . الهدف المعروض في هذه الأطروحة هو اقتراح نهج فعال يعتمد على المعايير الهندسية من أجل تحليل وتقييم أداء النظام الذي يستجيب لجميع خصائص نظام معقد مثل التطور والتفاعل والسلوك العياني من أجل تجنب الفشل وتلبية القيود المختلفة للسلامة التشغيلية .

الكلمات المفتاحية : السلامة التشغيلية ، طريقة تحليل أنماط الفشل و آثارها وخطورتها ، تقييم المخاطر ، اتخاذ القرار ، متعدد المعايير ، طريقة التحليل العلائقي الرمادي ، المنطق الضبابي ، طريقة التحليل الهرمي الضبابي ، نظام الاستدلال العصبي الضبابي .

La sûreté de fonctionnement dans l'ingénierie des systèmes complexes

Résumé :

L'intégration de diverses technologies dans ce monde qui se développe de jour en jour fait que les systèmes conçus sont plus complexes avec des comportements difficilement à prévoir. L'évaluation de la performance des systèmes industriels, du plus simple au plus complexe, est un élément essentiel dans la gestion des entreprises et dans la sûreté de fonctionnement. Ce dernier décrit et analyse les mécanismes qui conduisent aux incidents et aux défaillances du système. Les entreprises ont développées de nombreuses méthodes de recherche pour éviter ou prévenir contre les événements inattendus. L'Analyse des Modes de Défaillances, de leurs Effets et de leur Criticité. (FMECA) est couramment utilisée comme technique analytique fiable et proactive pour identifier, classer et réduire les défaillances. Cependant, dans de nombreux cas, il souffre de certaines lacunes concernant la prise de décision et la situation où les informations fournies sont ambiguës ou incertaines. L'objectif présenté dans cette thèse est de proposer une approche efficace basée sur les normes d'ingénierie afin d'analyser, estimer et évaluer les performances d'un système qui répond à toutes les caractéristiques d'un système complexe telles que l'émergence, l'interaction et son comportement macroscopique afin d'éviter le chaos et de satisfaire les différentes contraintes de sûreté de fonctionnement.

mots clés : sûreté de fonctionnement, AMDEC, Évaluation de la criticité, , Prise de décision, Multicritères, , AHP floue, Analyse relationnelle grise, Logique floue, Système d'inférence neuro-floue adaptatif .

Dependability in the engineering of complex systems

Abstract :

The integration of various technologies in this world that is developing day by day means that the systems designed are more and more complex with behaviors that are more difficult to predict. The evaluation of the performance of industrial systems, from the simple to the complex, is an essential element in the management of companies and in the dependability. The latter describes and analyzes the mechanisms that lead to incidents and system failures. Companies have evolved many research methods to avoid or prevent these unexpected events. Failure mode effect and criticality analysis (FMECA) is commonly utilized as a proactively reliable analytical technique for identifying, ranking, and reducing these failures. However, in many cases, it suffers from some shortcomings regarding the decision-making and the situation where the information provided is ambiguous or uncertain. The objective presented in this thesis is to propose an effective approach based on the engineering standards in order to analyze, estimate and evaluate the performance of a system that responds all the characteristics of a complex system such as emergence, interaction and its macroscopic behavior in order to avoid chaos and satisfy the various constraints of the dependability.

Keywords: dependability , FMECA, Criticality assessment, ,Decision- making, Multi-criteria, , Fuzzy AHP, Grey relational analysis, Fuzzy Logic, Adaptive neuro-fuzzy inference system.

Acknowledgements

*This thesis is the fruit of three years of work conducted at LISIDD (Laboratoire de l'Ingénierie de la Sécurité Industrielle et du Développement Durable) of IMSI (l'Institut de Maintenance et de Sécurité Industrielle). Big thanks to my **MOTHER**, my **FATHER**, who were able to surround me during my doctoral studies, their encouragement, support and love have never failed me. May they find here the expression of my deepest gratitude. My second sincere thanks go to my supervisor **Dr. CHENNOUFI MOHAMMED**. He has provided to me a continuous support during my stay at ORAN, contributing in a significant way to the progress of my research with suggestions and ideas that have improved the thesis in its present version. I owe gratitude to my colleagues of the LISIDD group and especially the group leader **Prof. ZOUBIDA LOUNIS**, for her expert guidance and the positive vision she has always had on my work. Among the other people, I wish to thank colleagues and friends of mine, **Dr. ISLAM HADJ MOHAMED GUETARNI** and **Dr. MOHAMMED BOUGOFA** who have contributed to the revision of part of my thesis since the very early stages. I would like to thank **Mr HASSINI ABDELATIF**, Professor at Mohamed Ben Ahmed Oran 2 University , **Mrs AISSANI NASSIMA**, MCA at Mohamed Ben Ahmed Oran 2 University, **Mr BOUAMRANE KARIM**, Professor at ahmed ben bella Oran 1 University and **Mr CHAKER KADER** Professor at Ecole National Polytechnique Oran , for agreeing to take part in the jury. I deeply appreciate the immense support of my dear friends, thank you for being here for me. Thank you to all those who have contributed directly or indirectly to the completion of this thesis*

General introduction

1. Problematic

Industry plays a crucial role in the economies of most countries, contributing (3.8% to 4%) of annual world gross domestic product. However, various activities, complex working environments, dangerous failures on processes, products, services, or equipment are frequently a source of challenge for any organization. To minimize or prevent these undesired catastrophes, organizations have created research methodologies. Failure mode, effects, and criticality analysis (FMECA) is a proactive quality tool that allows the identification and prevention of the potential failure modes of a process or product. However, it proves in a variety of applications that the FMECA still has several limitations:

- It's difficult to have precise numbers to evaluate the criticality value when failure modes are assessed in a complicated system.
- Due to the lack of a full theoretical understanding of its sources, RPN calculating function is frequently questioned.
- The FMECA with the calculation of a single criticality is insufficient for the relevance of decision-making.
- Various combinations of S, F and ND factors may give a similar RPN value. However, the criticality evaluation for the failure modes can be vastly dissimilar
- In the estimation of RPN, the relative importance of criticality parameters is not considered.
- Another drawback of the classical RPN is the specific evaluation of criticality parameters regarding each failure mode. However, because of limited data, time pressure, or experts' information processing abilities are limited, risk parameters cannot be specified precisely, and the criticality evaluation information may be uncertain or imprecise

According to the shortcomings cited above we will try in this work to improve the used of failure mode, effects and criticality analysis by using new proposed modellings especially based on multi-criteria decision making (MCDM), and Artificial intelligence approaches (AI).

2. Objectives of the thesis

The main purpose of this work is to estimate and evaluate the performance that responds all the characteristics of a complex system by study the contribution of fuzzy artificial intelligence (Adaptive neuro-fuzzy inference system and Fuzzy logic) and multi-criteria

decision making methods the grey relational approach (GRA) and fuzzy analytic hierarchy in the risk evaluation and prioritizing failures mode and decision makers guidance to refine the relevance of decision making in order to reduce the probability of occurrence and the severity of the undesirable scenarios with handling different forms of ambiguity, uncertainty, and divergent judgments of experts

The approach has been validated experimentally on operational industrial systems that are: a gas turbine and LPG storage system.

3. The contribution

The contributions and innovations of our work are summarized as follows:

a) To avoid the complexity and uncertainty of information, for each failure mode the authors replaced the one global criticality calculated from the classical method with a fuzzy inference system that offers five different criticalities that efficiently and separately calculate the impact of a failure on the environment, personnel, production, equipment, and management.

b) Due to the doubts of the fuzzy system (if-then rules limits) that cannot give a precise numerical evaluation of criticality, the calculation of the overall criticality is based on a combination between AHP method to calculate the different priorities weights and the five partial criticalities calculated by the fuzzy inference system.

c) our work can not only deal with identification, evaluation, and ranking failure modes as it was in previous researches, and not only deal with the subjectivity and vagueness but also to improve the aptitude of decision-making by trying to implement an action plan “preventive – corrective actions” in order to take priority of these actions and comparing their classifications towards each criticality importance (environment, personnel, production, equipment, and management) to reduce the frequency of occurrence and the severity of undesirable scenarios and safety improvement effectively.

d) An adaptable neural network-based fuzzy inference system is created to compare and validate the results obtained by fuzzy inference system assessment; it's simple to combine both numeric and linguistic knowledge in order to solve the fuzzy problem produced.

e) Different approaches can give different prioritizations, and every approach has its disadvantages and advantages. Consequently, the integration of two multi-criteria decision methods and incorporating their results enables to instill confidence in decision-makers

regarding to the criticality prioritizations results of failure modes, especially when dealing with complicated systems. Wherefore, in this work, a novel hybrid approach that combines the grey relational approach (GRA) and fuzzy analytic hierarchy process may solve this problem. This approach gives an alternate prioritizing for the failure modes and allows overcoming the shortcomings concerning the lack of established inference rules which necessitate a good deal of expertise, and shows the weightage or importance for the severity, non-detection, and the frequency which are considered to have equal importance in the traditional method.

4. General plan of the thesis

This thesis decomposed into five chapters organized as follows:

The first chapter introduced the Preamble of this work. The literature review on dependability analysis is the subject of the second chapter. The criticality evaluation in FMECA method of the industrial risks is presented in the third chapter, Therefore we propose a framework for classifying the reviewed tools and methodology depending upon the failure mode evaluation and prioritization. An industrial cases study is presented in the fourth chapter to demonstrate the application of conventional FMECA method, the results obtained as a summary of this chapter will be used as the prior data for the development and improving the classical FMECA method and ameliorating the relevance of decision making in the fifth and last chapter by proposing new modeling to assess and prioritization the failures mode of the catastrophic scenarios. Finally, we will conclude our work with a conclusion which will recapitulate our approaches and our results; this allows highlighting the critiques which open an axis to the perspectives for future research around the subject of this thesis.

Chapter I

Literature review on analysis by dependability

1.1. Introduction

Many analysis techniques have been applied by the engineers to assess the system dependability during the last four decades. Such techniques are used for the prediction, verification, and improvement of dependability properties[1, 2]. The dependability appeared relatively recently by comparison with other fields of engineering, from the 1940 in the field of aeronautics, followed by the arms industry and the nuclear sector between 1960 and 1970 following failures in systems. The dependability is a discipline more and more used in industrial systems for security control, availability improvement and ensuring reliability while taking into consideration the cost notion[3]. In recent years, dependability has acquired multiple methods that allow the diagnosis and control of the reliability, availability, maintainability and security of systems. They help in answering the questions that are most pressing to an engineer, such as: When a shutdown occurs, how long does it take to recover the system? Is the system able to provide the service to the user during a given time period? And so on.

Dependability in the engineering field and as well as its development is as a multi-tool discipline[4]:

- Risk analysis methods;
- Methods of predictive calculations of the safety of systems;
- Software tools dedicated to safety ;
- Constitution of statistical databases on the reliability of components.

After this brief introduction to the development of dependability, this chapter presents the overall framework of our developments. We will present the various concepts and definitions useful in the dependability of systems, and the various associated bases such as reliability, availability, maintainability, safety and then present the approaches and methods most used in the study of the dependability of systems.

1.2. Dependability of system

The increasing complexity of industrial systems, the reduction of their design and operating costs, make dependability an unavoidable domain in the development of any industrial system.

1.2.1. Definition of dependability

Dependability is a general notion characterized as the science of failures, risk analysis, or reliability, availability, maintainability and security[5-7]. It encompasses the knowledge of failures, their evaluation, their prediction and their control. It is characterized by both static and dynamic structural studies of systems,

Dependability is based on:

- Methods and tools used to characterize and control the effects of hazards, failures and errors,
- The quantification of the characteristics of components and systems to express the conformity in time of their behaviors and their actions.

Dependability is not only reduced to one of these performances of reliability, maintainability, availability and safety, but it is built through all these characteristics[3, 8].

1.2.2. Components of the dependability

Dependability is the measure for the quality of service in time given by the system. It encompasses the notions of availability, reliability, safety, maintainability and other more specialized attributes. Dependability is defined 'the ability of the system to deliver a service that can be justifiably trusted' but other definitions are given by international standards authorities like ISO.

1.2.2.1. Reliability $R(t)$

It represents the continuity of correct service[9]. It is also defined the probability that it performs the required functions under given conditions during for a period of time between 0 and t, knowing that the entity is not down at time 0 and cannot operate forever, we can consider that[10]:

- $R(t)$ is a non-increasing function varying from 0 to 1 on $[0, +\infty [$
- $\lim_{t \rightarrow +\infty} R(t) = 0$
- The unreliability $F(t)$. It is the complement to 1 of reliability, is defined as $F(t)=1-R(t)$.

The reliability is a decreasing function of time (Figure 1.1), such that: $R(t_1) > R(t_2)$ if $t_1 < t_2$.

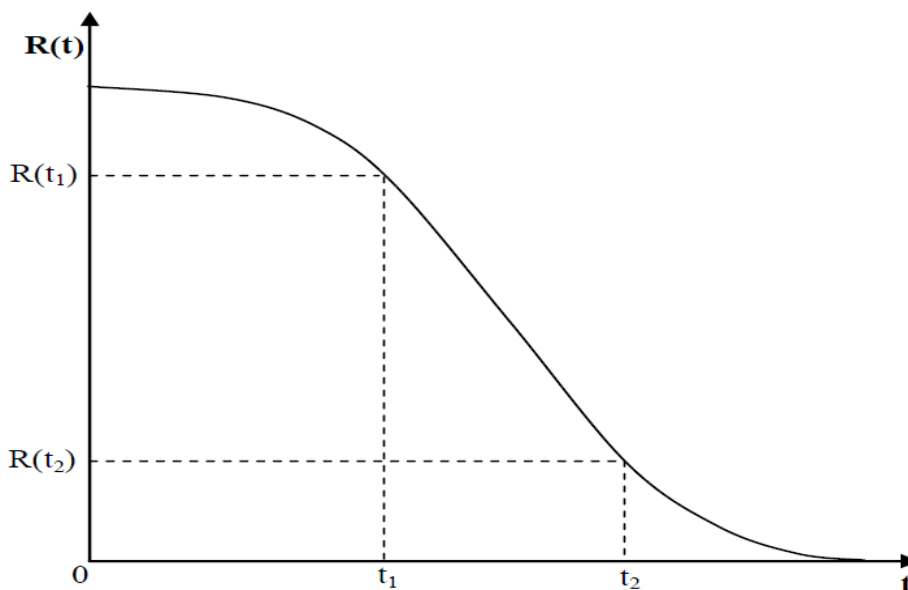

Figure 1. 1Reliability decreases over time

1.2.2.2. Availability A(t)

During the system lifetime, just one outage being unacceptable for a reliable system. Availability is always required, although to a varying degree depending on the application[11]. In the case of a non-repairable component, availability and reliability merge: $A(t) \sim R(t)$ in the opposite case: $A(t) \geq R(t)$. The unavailability $U(t)$ is the complement to 1 of the availability, is defined as: $U(t) = 1 - A(t)$ [12].

1.2.2.3. Safety

Safety distinguishes from availability and reliability for the consequence of the service outage, which is ranked according to a severity level. It represents the absence of catastrophic consequences in case of failure[13].

1.2.2.4. Maintainability

It is the ability to undergo modifications and repairs between 0 and t. Maintainability is the measure of the repair process including fault diagnosis, localization and isolation plus repair or replacement[14, 15].

- $M(t)$ is a non-decreasing function varying from 0 to 1 on $[0, +\infty[$;
- $\lim_{t \rightarrow +\infty} M(t) = 1$

1.2.3. The Means to Attain Dependability

Over the course of the past fifty years many means to attain the attributes of dependability have been developed. Those means can be grouped into four major categories[16]:

- Fault prevention: means to prevent the occurrence or introduction of faults;

Chapter I: Literature review on analysis by dependability

- Fault tolerance: means to avoid service failures in the presence of faults;
- Fault removal: means to reduce the number and severity of faults;
- Fault forecasting: means to estimate the present number, the future incidence, and the likely consequences of faults

Fault prevention and fault tolerance aim to provide the ability to deliver a service that can be trusted, while fault removal and fault forecasting aim to reach confidence in that ability by justifying that the functional and dependability specifications are adequate and that the system is likely to meet them[17].

1.3. Concept of System

1.3.1. System definition

A system is a set of interdependent components, designed to perform a given function, under given conditions and within a given time interval[18-20]. For each system, it is important to clearly define the elements that characterize it, namely: function, structure, operating conditions, and the environment.

A system can also be defined an “organized whole in which parts are related together, which generates emergent properties and has some purpose”. However, when scoping a “problem-system”, besides its parts and purpose, there are two distinctive features to consider:

A system may be open to the influence of its environment (physical, political, social, and organizational)? Along this line, there are “Open Systems” that interact with and/or are influenced by their environment, versus “Closed Systems” that has no or little interaction with the environment (e.g., a turbo engine)[21].

With regard to the relationships among system components: There are “Complicated system” that may have multiple components, but the relationships among components are more of a linear “action-reaction” fashion that is largely predictable. To the contrary, there are “Complex Systems” with at least one non-linear relationship between at least one pair of components, and such systems are often open systems. The distinction between a complex system and a complicated system as shown in Figure 1.2.

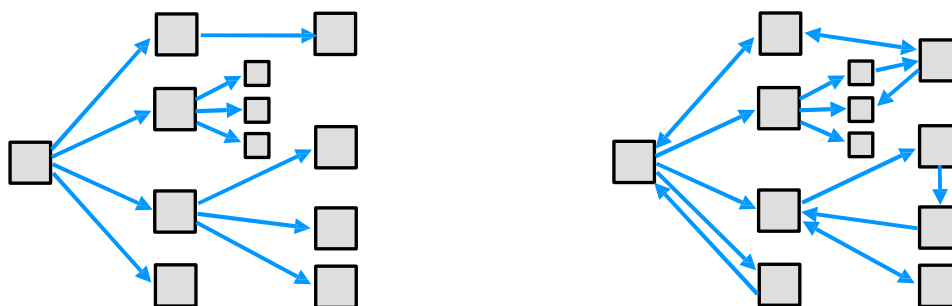

Figure 1.2 Difference between complicated system and complex system

1.3.2. Complexity

"Systems exhibit complexity" means that their behaviors cannot be easily inferred from their properties[22]. Any modeling approach that ignores such difficulties or characterizes them as noise, then, will necessarily produce models that are neither accurate nor useful. As yet no fully general theory of complex systems has emerged for addressing these problems, so researchers must solve them in domain-specific contexts. Researchers in complex systems address these problems by viewing the chief task of modeling to be capturing, rather than reducing, the complexity of their respective systems of interest[23]. While no generally accepted exact definition of complexity exists yet, there are many archetypal examples of complexity[24]. Systems can be complex if, for instance, they have chaotic behavior (behavior that exhibits extreme sensitivity to initial conditions, among other properties), or if they have emergent properties (properties that are not apparent from their components in isolation but which result from the relationships and dependencies they form when placed together in a system), or if they are computationally intractable to model (if they depend on a number of parameters that grows too rapidly with respect to the size of the system)[25].

1.3.3. Features of complex systems

1.3.3.1. Emergence

Another common feature of complex systems is the presence of emergent behaviors and properties: these are traits of a system that are not apparent from its components in isolation but which result from the interactions, dependencies, or relationships they form when placed together in a system[26]. Emergence broadly describes the appearance of such behaviors and properties, and has applications to systems studied in both the social and physical sciences. While emergence is often used to refer only to the appearance of unplanned organized behavior in a complex system, emergence can also refer to the breakdown of an organization; it describes any phenomena which are difficult or even impossible to predict from the smaller

Chapter I: Literature review on analysis by dependability

entities that make up the system[27]. One example of a complex system whose emergent properties have been studied extensively is cellular automata. In a cellular automaton, a grid of cells, each having one of the finitely many states, evolves according to a simple set of rules. These rules guide the "interactions" of each cell with its neighbors. Although the rules are only defined locally, they have been shown capable of producing globally interesting behavior.

1.3.3.2. Nonlinearity

Complex systems often have nonlinear behavior, meaning they may respond in different ways to the same input depending on their state or context[27]. In mathematics and physics, nonlinearity describes systems in which a change in the size of the input does not produce a proportional change in the size of the output. For a given change in input, such systems may yield significantly greater than or less than proportional changes in output, or even no output at all, depending on the current state of the system or its parameter values. Of particular interest to complex systems are nonlinear dynamical systems, which are systems of differential equations that have one or more nonlinear terms. Some nonlinear dynamical systems, such as the Lorenz system, can produce a mathematical phenomenon known as chaos. Chaos, as it applies to complex systems, refers to the sensitive dependence on initial conditions, which a complex system can exhibit. In such a system, small changes to initial conditions can lead to dramatically different outcomes. Chaotic behavior can, therefore, be extremely hard to model numerically, because small rounding errors at an intermediate stage of computation can cause the model to generate completely inaccurate output. Furthermore, if a complex system returns to a state similar to one it held previously, it may behave completely differently in response to the same stimuli, so chaos also poses challenges for extrapolating from experience[28].

1.3.3.3. Hierarchical organization

In complex systems there are often many levels of organization that can be thought of as forming a hierarchy of system and sub-system as proposed by Herbert Simon in his famous paper 'The Architecture of Complexity'. The ultimate result of all the features of complex systems above is an entity that is organized into a variety of levels of structure and properties that interact with the level above and below and exhibit lawlike and causal regularities, and various kinds of symmetry, order and periodic behavior[29].

1.3.3.4. Robustness and lack of central control

The order in complex systems is said to be robust because, being distributed and not centrally produced, it is stable under perturbations of the system. A centrally controlled system on the other hand is vulnerable to the malfunction of a few key components. Clearly, while

lack of central control is always a feature of complex systems it is not sufficient for complexity since non-complex systems may have no control or order at all. A system may maintain its order in part by utilizing an error-correction mechanism[30].

1.4. Systems engineering

Systems engineering is an interdisciplinary field of engineering and engineering management that focuses on how to design, integrate, and manage complex systems over their life cycles[31, 32]. At its core, systems engineering utilizes systems thinking principles to organize this body of knowledge. The individual outcome of such efforts, an engineered system, can be defined as a combination of components that work in synergy to collectively perform a useful function. Issues such as requirements engineering, reliability, logistics, coordination of different teams, testing and evaluation, maintainability and many other disciplines necessary for successful system design, development, implementation, and ultimate decommission become more difficult when dealing with large or complex projects. Systems engineering deals with work processes, optimization methods, and risk management tools in such projects[33]. It overlaps technical and human-centered disciplines such as industrial engineering, process systems engineering, mechanical engineering, manufacturing engineering, production engineering, control engineering, software engineering, electrical engineering, cybernetics, aerospace engineering, organizational studies, civil engineering and project management. Systems engineering ensures that all likely aspects of a project or system are considered and integrated into a whole. The systems engineering process is a discovery process that is quite unlike a manufacturing process. A manufacturing process is focused on repetitive activities that achieve high quality outputs with minimum cost and time. The systems engineering process must begin by discovering the real problems that need to be resolved, and identifying the most probable or highest impact failures that can occur – systems engineering involves finding solutions to these problems.

1.4.1. Life cycle and development cycle

When dealing with Systems Engineering, it is essential to consider the product development cycle and its lifecycle[34, 35]. The best-known development cycle, which first appeared in the computer field, is unquestionably the V-cycle. This is made up of 2 branches. The descending branch corresponds to an approach of successive refinements which responds to the design phase, starting from the general (the expression of needs often through a

Functional Specifications) to lead to the particular. The ascending branch, for its part, details the phases of integration and validation of the system[36].

1.4.2. Exigencies engineering

A point of System Engineering on which part of our work is focused concerns exigencies engineering. This is a very important part of systems engineering, which is in charge of all activities related to requirements such as their definition, traceability, modification, management in terms of maturity, etc. The following section therefore attempts to present the main concepts and interests of these exigencies engineering and begins, first, with the definition of a requirement.

1.4.2.1. Definition of an exigency

An exigency is a well-formulated expression of need from the customer or any other stakeholder related to the system to be developed[37, 38]. It conveys a need in functionality (functional requirement) or in quality (non-functional requirement) that must satisfy the product that is being designed. Concerning the non-functional requirements, they can represent:

- Global constraints of quality of service,
- System capabilities (reliability, operability, conviviality, ...),
- Operational constraints (compliance with usage standards),
- Design constraints (reuse of existing).

The main interest of transcribing the needs into exigencies lies in the non-ambiguity that must result from their formulation. Moreover, this provides a good communication medium between the different project stakeholders who must collaborate.

1.4.2.2. Role and interest of exigencies engineering

Managing the exigencies in a project is a fundamental activity for its smooth running. Indeed, a large number of documents can be produced when designing a system[39]. Without requirements engineering, it would be almost impossible to guarantee the consistency and quality necessary for the success of the project. Indeed, statistical studies have shown that exigencies are involved in about 40% of the successes or failures of a project, hence their importance to our concern.

Thus, exigencies engineering makes it possible to:

- collect exigencies,
- facilitate their expression,

Chapter I: Literature review on analysis by dependability

- detect inconsistencies between them,
- validate them,
- manage their priority (prioritize them),
- manage changes in exigencies,
- manage quality,
- make the link with the rest of the project and / or with the context,
- And still ensure their traceability.

Exigencies engineering must also ensure that each exigency is correctly stated, allocated, monitored, satisfied, verified and justified. We understand the importance of exigencies engineering in a project, to its success, and therefore to ensuring that the designed system will meet the needs and perform as intended. Any deviation from compliance with the exigencies may be the cause of undesired operation, hence the link with our problem.

In particular, we saw the importance of the requirements related to interfaces, which are still too often the cause of design problems, and therefore delays and additional costs. Below, we will focus on three major aspects of the engineering of exigencies: the expression of exigencies, traceability and change of exigencies.

1.4.2.3. Expression of exigencies

A good expression of exigencies is a key point for the success of a project[40]. Any ambiguity or oversight at this level will be a source of further complication, which may of course result in delays, additional costs, penalties, etc. We must ensure that the interpretations that can be made by the different stakeholders are the same. To do this, use simple terms and avoid ambiguous or vague terms. It is also recommended to attach standard diagrams or models that can clarify the requirement as soon as possible. (We recall here the well-known adage: “a good diagram is better than a long speech”.) Besides the very formulation of the “need” expressed through the exigency, to this one can also be associated other attributes such as: the type (primary or derived), the level of compliance (mandatory, advice or information), the priority, the scope (requirement on the system itself or the program) or the state (verified, validated ...). All this information is important and must be kept up to date.

1.4.2.4. Traceability

Exigencies traceability is the most important concept in exigencies engineering. It allows you to easily know the origin of the exigencies, as well as all the links between the exigencies themselves or between the exigencies and the rest of the project or the context (user needs,

Chapter I: Literature review on analysis by dependability

implementation, tests, etc.)[41]. Traceability is cited as a quality factor of good design. First of all in order to describe the connections between the different levels of exigencies, it presents a set of advantages that allow:

- to show more easily that the design satisfies the exigencies and to help quickly identify which requirements are not satisfied by the solution (in other words: to verify / validate the proposed solution),
- Never lose any justification vis-à-vis design choices,
- to facilitate and control the evolution of the system in the future,
- Understand the impact of a change in exigencies and facilitate the consideration of changes.

1.4.2.5. Change of requirements

Changing requirements is an integral part of requirements engineering. It is then necessary to guarantee traceability, as we have just explained above. Poorly monitored, the change in requirements has often been the source of serious design problems. These lead to delays and additional costs that are detrimental to the survival of the company, and even to major system malfunctions affecting the security of property and / or people. Good requirements engineering, with full traceability where all the necessary information is present, should make it possible to analyze and take into account the impact of changes in requirements. Changes which are becoming more and more inevitable, on the one hand, due to the complexity of the systems which requires initial assumptions to be reviewed and adjusted later in the development, on the other hand, due to the arrival new technologies or more simply because of the rapid evolution of the current market. Another important aspect that further complicates the task of requirements engineering is that multiple stakeholders and different design actors are involved to define and address requirements. Behind this idea, there is the notion of collaborative work, and therefore collaborative management of requirements. This is the subject of much work and constitutes a field of research in its own right.

1.5. Risk management

Risk management is an important activity for the smooth running of the design project[42, 43]. It is a system engineering activity that we must present, given our problem, which requires risk management. Thus, in this section, we first give the definition of a risk and we justify the interest of the risk study. Then we present the strategies and tools of risk management.

1.5.1. Definition of a risk

A risk is a potential loss or degradation, identified and often quantifiable[44, 45]. It is a more or less predictable possible danger that can affect the outcome of the project. It is necessarily linked to a situation or an activity and is associated with the probability of the occurrence of an event or a series of events. It can be characterized by a two-dimensional quantity. Figure 1.3 illustrates this characteristic:

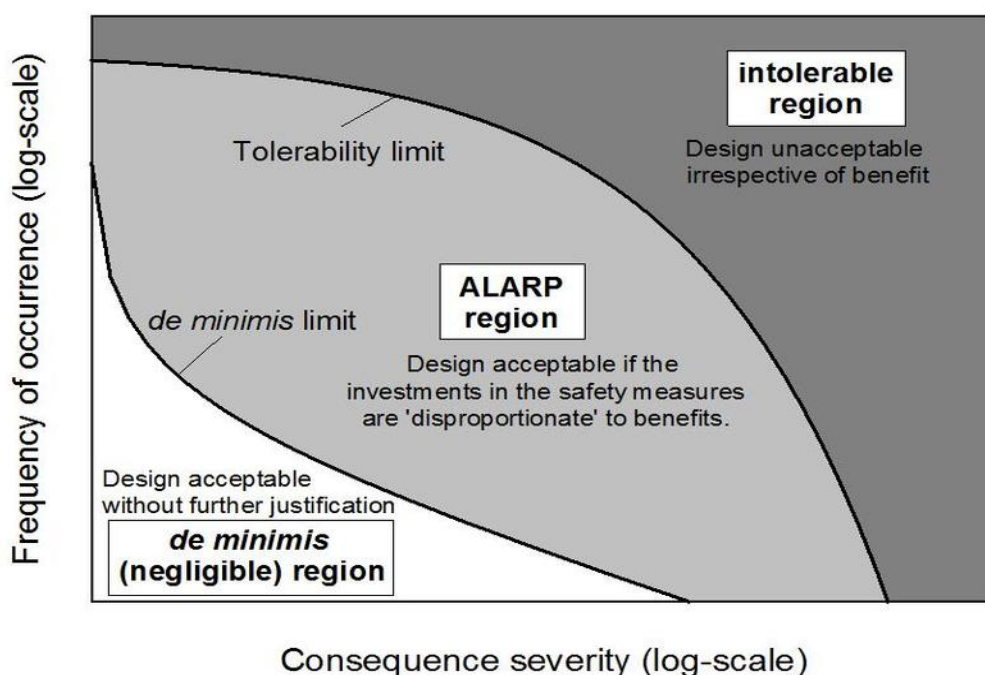

Figure 1.3 Risk criticality

In this Figure 1.3, we can already identify the risk reduction strategy which consists of reducing its probability of occurrence (prevention) and / or reducing its severity (protection) to make the risk acceptable. In fact, the first scientific definition of risk was given in 1738 by Daniel Bernoulli in “Specimen theoriae novae de mensura sortis”[46]: “risk is the mathematical expectation of a function of probability of events”. More simply, it is the average value of the consequences of events weighted by their probabilities. In this definition, we find the notion of probability and the severity through the representative value of the consequences of events. But other elements are to be associated with the risks such as: the consequences themselves, the risk management strategy, the tool used to apply the strategy, and of course the factor or factors of the appearance of the risk[47].

1.5.2. Why be interested in risks

Taking risks into account is essential for good project management. Indeed, they can be responsible for the failure of the project or, at the very least, for a not insignificant increase in the cost or the time of development. Taking an interest in the risks would therefore help to avoid these kinds of problems. This would reduce the number and cost of accidents, prevent disabling or fatal accidents, or more simply avoid customer dissatisfaction[48].

From a global point of view, we can identify two main families of risks:

- The risks present during the operation of the system and directly related to the system and its operation. Typically, these are the risks that dependability will treat. For example, there are those relating to a failure of a subsystem or a component, or those relating to the protection of persons using the system.
- Risks linked to the project or to the development itself. They do not intervene directly in the dependability of the system. On the other hand, they can be the source of risks of the first type. As an example, we can cite the risk due to the delay of a supplier or that caused by encountering a technical difficulty greater than expected in the development phase. This in both cases could result in a delay in the completion of the design, possibly accompanied by greater pressure on the development managers which can be a factor in the increase in the number of design errors (from where the link with the risks associated with the system and dependability).

1.6. Description of risk analysis methods

1.6.1. Qualitative / Quantitative

1.6.1.1. Qualitative methods

It enumerates all failure mechanisms in the system and their consequences. A qualitative analysis is appropriate when there isn't enough time, money, the lack of data may be due to the uniqueness of a particular risk, which could include unusual threats or vulnerabilities, or a one-of-a-kind asset.

1.6.1.2. Quantitative methods

It uses available relevant and verifiable data to produce a numerical value which is then used to predict the probability (and hence, acceptability) of a risk event outcome.

1.6.2. Statics / dynamics

1.6.2.1. Static methods

It allow to analyze the system from a structural point of view without taking into account the evolutions in the course of time and are based on a Boolean mathematical model of the system. For instance, the combinations of failures leading to the dysfunction of the system but without representing the temporal interrelations which affect it.

1.6.2.2. Dynamic methods

A list of the primary techniques, recommended by the international standard (IEC-60300-3-1 2003) for the dependability assessment, is shown in Table 1.1:

Table 1.1 Primary dependability analysis techniques IEC-60300-3-1

Technique	Other standards	Qualitative/ quantitative
Event Trees Analysis (ETA)	IEC-62502 (2010)	Qualitative Quantitative
Failure Mode and Effect Analysis (FMEA)	IEC-60812 (1985), MIL-STD-1629a (1980), ANSI/IEEE-STD-352 (1987), SAE-ARP-4761 (1996); BS-5760-5 (1991)	Qualitative
Failure Mode, Effect, and Criticality Analysis (FMECA)	IEC-60812 (1985); MIL-STD-1629a (1980); BS-5760-5 (1991)	Qualitative
Fault Trees Analysis (FTA)	IEC-61025 (2006), ANSI/IEEE-STD-352 (1987), SAE-ARP-4761 (1996)	Qualitative Quantitative
Functional Failure Analysis (FFA)	SAE-ARP-4761 (1996)	Qualitative
Hazard and Operability studies (HAZOP)	IEC-61882 (2001)	Qualitative
Markov analysis	IEC-61165 (2006), ANSI/IEEE-STD-352	Qualitative Quantitative

	(1987)	
Petri Net analysis (PN)	ISO/IEC-15909-1 (2004)	Qualitative Quantitative
Preliminary Hazard Analysis (PHA)	MIL-STD-882c (1993), MIL-STD-882d (2000)	Qualitative
Reliability Block Diagrams analysis (RBD)	IEC-61078 (2006), ANSI/IEEE-STD-352 (1987)	Qualitative

1.7. Dysfunctional analysis and assessment

The methods used for dysfunctional analysis come in various forms: tabular forms, tree structure, networks, and graphs.

1.7.1. FMEA / FMECA

Failure Mode and Effect Analysis (FMEA) is an inductive analysis technique used to study the effects of component failure modes on a system[49, 50]. FMEA starts from knowledge of component failure modes and considers the effects of each failure on sub-systems and the system. It implies the study of all the components in a system and is often applied to higher-level assemblies and systems. FMEA helps to check whether the components, with their known failure modes, fulfill system level safety requirements. The results of the FMEA may be to accept the proposed components or, perhaps, to issue recommendations for maintenance checks, or to ask for components to be replaced. It is common to use FMEA to determine the presence or absence of single points of failures in a system design. FMEA is basically a qualitative technique; Failure Mode, Effect and Criticality Analysis (FMECA) extends FMEA by introducing a criticality analysis to verify whether failure modes with severe effects have sufficiently low occurrence probability. Both the techniques produce tabular outputs[51, 52].

Figure 1.5 shows the flow chart revealing general procedure for carrying out FMEA process. In brief, the ten steps involved are as described as follows:

- (1) Define the scale Table of Severity, Occurrence, and Detect.
- (2) Studies intent, purpose, goal, objective of a product/process. Generally, it is identified by interaction among components/process flow diagram followed by task analysis.
- (3) Identify potential failures of product/process; this includes problems, concerns, and opportunity of improvement.

Chapter I: Literature review on analysis by dependability

- (4) Identify consequence of failures to other components/next processes, operation, customers and government regulations.
- (5) Identify the potential root cause of potential failures.
- (6) First level method/procedure to detect/prevent failures of product/process.
- (7) Severity rating: rank the seriousness of the effect of the potential failures.
- (8) Occurrence rating: estimation of the frequency for a potential cause of failures.
- (9) Detect rating: likelihood of the process control to detect a specific root cause of a failure.
- (10) RPN calculation: product of the three inputs rating; severity, occurrence, detect.
- (11) Correction. Back to (2) if available.
- (12) End.

1.7.2. Fault Tree Analysis

The FTA is a systematic top-down method which starts from an assumption of a system failure followed by identification of the modes of system or component behavior that has contributed to this failure. These modes of system or component are not confined to hardware or software but include other factors such as human factors or interaction[53]. FTA is particularly useful when quantitative data on probability is available although qualitative analysis can also be performed. In either case, an FTA can pinpoint common factors or the factors that are the highest contributor of system failure. This is not as readily identifiable using other risk analysis techniques such as FMECA. Its visual representation of the causes of the failure allows easy identification of a single fault event (a single failure that triggers a complete system failure)[54]. Where quantitative data is available, the probability of failures can be anticipated through mathematical calculations. The FTA is comprised of a top event and a series of symbols, events, and logic gates for the construction of the tree. Some of the symbols commonly used in an FTA are shown in Table 1.2. Refer to IEC 61025 for more symbols used in an FTA. For complicated systems, the FTA diagram may become very large when the system failure is at a very high level. For example, a top event such as “system no response” in an electrical device may be due to numerous causes. In the absence of software to track the FTA, it is more practical to consider intermediate undesirable events such as “input power cut” or “transformer failure.” This also allows different functional teams to work on various aspects of the FTA before combining at a later stage.

1.7.2.1. Fault Tree Construction

Chapter I: Literature review on analysis by dependability

FTA is a deductive technique where we start with the failure scenario being considered, and decompose the failure symptom into its possible causes. Each possible cause is then investigated and further refined until the basic causes of the failure are understood. The failure scenario to be analyzed is normally called the TOP event of the fault tree. The basic causes are the basic events of the fault tree. The fault tree should be completed in levels, and they should be built from top to bottom. However, various branches of a fault tree can be built to achieve different levels of granularity[55, 56].

1.7.2.2. Construction Guidelines

To achieve a consistent analysis, the following steps are suggested for constructing a successful fault tree model:

1) Define the undesired event to be analyzed. The description of it should provide answers to the following questions:

- a. What: describe what type of undesired event is occurring
- b. Where: describe where the undesired event occurs
- c. When: describe when the undesired event occurs

2) Define boundary conditions for the analysis, including

a. Physical boundaries: define what constitutes the system, i.e. which parts of the system will be included in the FTA.

b. Boundary conditions concerning environmental stresses: define what type of external stresses (e.g., earthquake and bomb) should be included in the fault tree.

c. Level of resolution: determine how far down in detail we should go to identify the potential reasons for a failed state.

3) Identify and evaluate fault events, i.e., contributors to the undesired TOP event: if a fault event represents a primary failure, it is classified as a basic event; if the fault event represents a secondary failure, it is classified as an intermediate event that requires a further investigation to identify the prime causes.

4) Complete the gates: all inputs of a particular gate should be completely defined before further analysis of any one of them is undertaken (complete-the-gate rule). The fault tree should be developed in levels, and each level should be completed before any consideration is given to the next level.

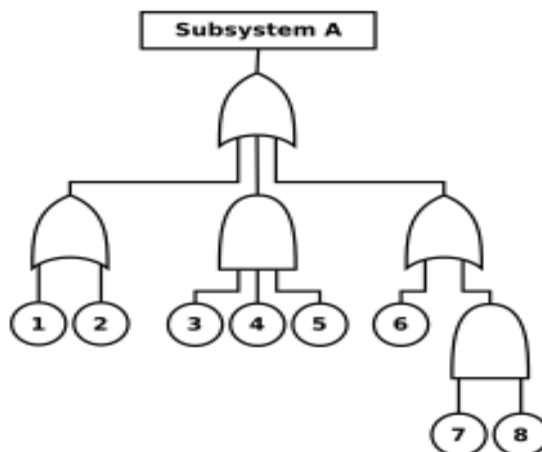
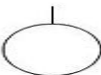



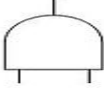

Figure 1.4 Example of a fault tree structure

Table 1.2 Traditional Fault Tree Event Symbols

The primary event symbols	Event and gate symbols	Description
Basic event		failure or error in a system component or element
External event		An event that is normally expected to occur. In general, these events can be set to occur or not occur (i.e., they have a fixed probability of 0 or 1).
Undeveloped event		An event which is no further developed. It is a basic event that does not need further resolution.

Chapter I: Literature review on analysis by dependability

Conditioning event		conditions that restrict or affect logic gates (example: mode of operation in effect)
OR gate		the output occurs if any input occurs.
AND gate		the output occurs only if all inputs occur (inputs are independent).

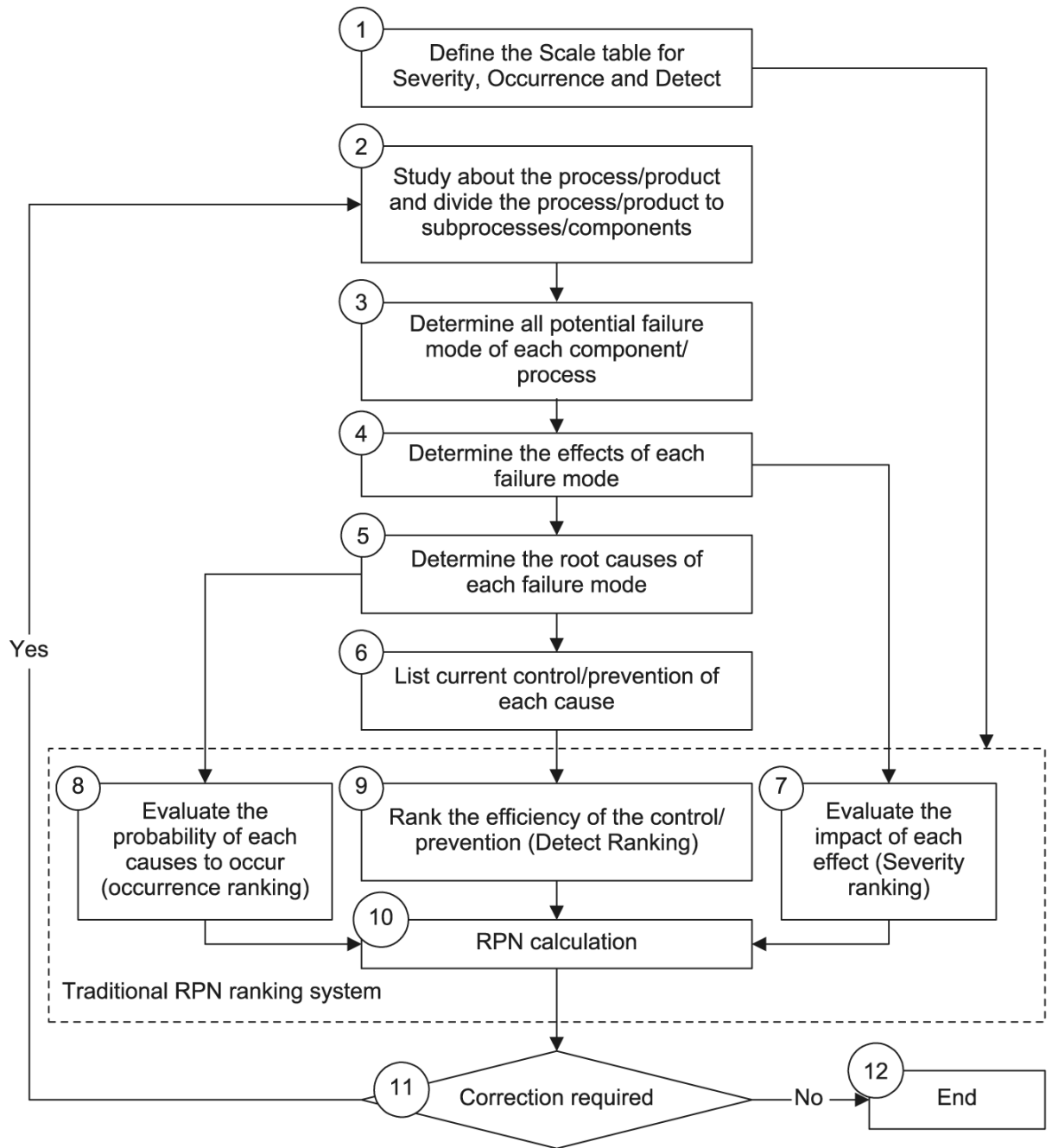

Figure 1.5 Flow chart for the sequential procedure of FMEA analysis

1.7.3. Event Tree Analysis

Event Tree analysis (ETA) is an inductive technique used to evaluate the consequences of an initiating event and the probability of each of the possible sequences that can occur. The Event Tree (ET) is a logical structure suitable to model the consequences of the initiating event (e.g., a node breakdown), identifying the states (success or unsuccess) of all the mitigation systems; the result is a set of different possible scenarios, each associated with an occurrence

Chapter I: Literature review on analysis by dependability

probability[57]. The Fault Tree analysis is generally used to calculate the probabilities of event occurrences. Indeed, each event (branch) in the ET can be interpreted as the top event of an FT: the value thus computed represents the conditional probability of the occurrence of the event, given that the events which proceed on that sequence have occurred. Multiplication of the conditional probabilities for each branch in a sequence gives the probability of that sequence. In the case of structural dependencies it is possible to combine ET and FT techniques in a profitable way, linking one FT to each ET branch. This combined technique is called ET with boundary conditions and consists in decomposing the system so as to identify the supporting part or functions upon which some components and systems are simultaneously dependent. The supporting parts thereby identified appear explicitly as system event tree headings, preceding the dependent protection systems and components. Since the dependent parts are extracted and explicitly treated as boundary condition in the ET, all the conditional probabilities are made independent and the probability of the accident sequences can be computed by simple multiplications[58].

1.7.3.1. Event tree methodology

The overall goal of event tree analysis is to determine the probability of possible negative outcomes that can cause harm and result from the chosen initiating event. It is necessary to use detailed information about a system to understand intermediate events, accident scenarios, and initiating events to construct the event tree diagram. The event tree begins with the initiating event where consequences of this event follow in a binary (success/failure) manner. Each event creates a path in which a series of successes or failures will occur where the overall probability of occurrence for that path can be calculated. The probabilities of failures for intermediate events can be calculated using fault tree analysis and the probability of success can be calculated from $1 = \text{probability of success (ps)} + \text{probability of failure (pf)}$. The event tree diagram models all possible pathways from the initiating event. The initiating event starts at the left side as a horizontal line that branch vertically. As shown in figure 1.6, the vertical branch is representative of the success/failure of the initiating event[59, 60].

Steps to perform an event tree analysis:

1. Identify (and define) a relevant accidental (initial) event that may give rise to unwanted consequences
2. Identify the barriers that are designed to deal with the accidental event
3. Construct the event tree
4. Describe the (potential) resulting accident sequences

Chapter I: Literature review on analysis by dependability

5. Determine the frequency of the accidental event and the (conditional) probabilities of the branches in the event tree
6. Calculate the probabilities/frequencies for the identified consequences (outcomes)
7. Compile and present the results from the analysis

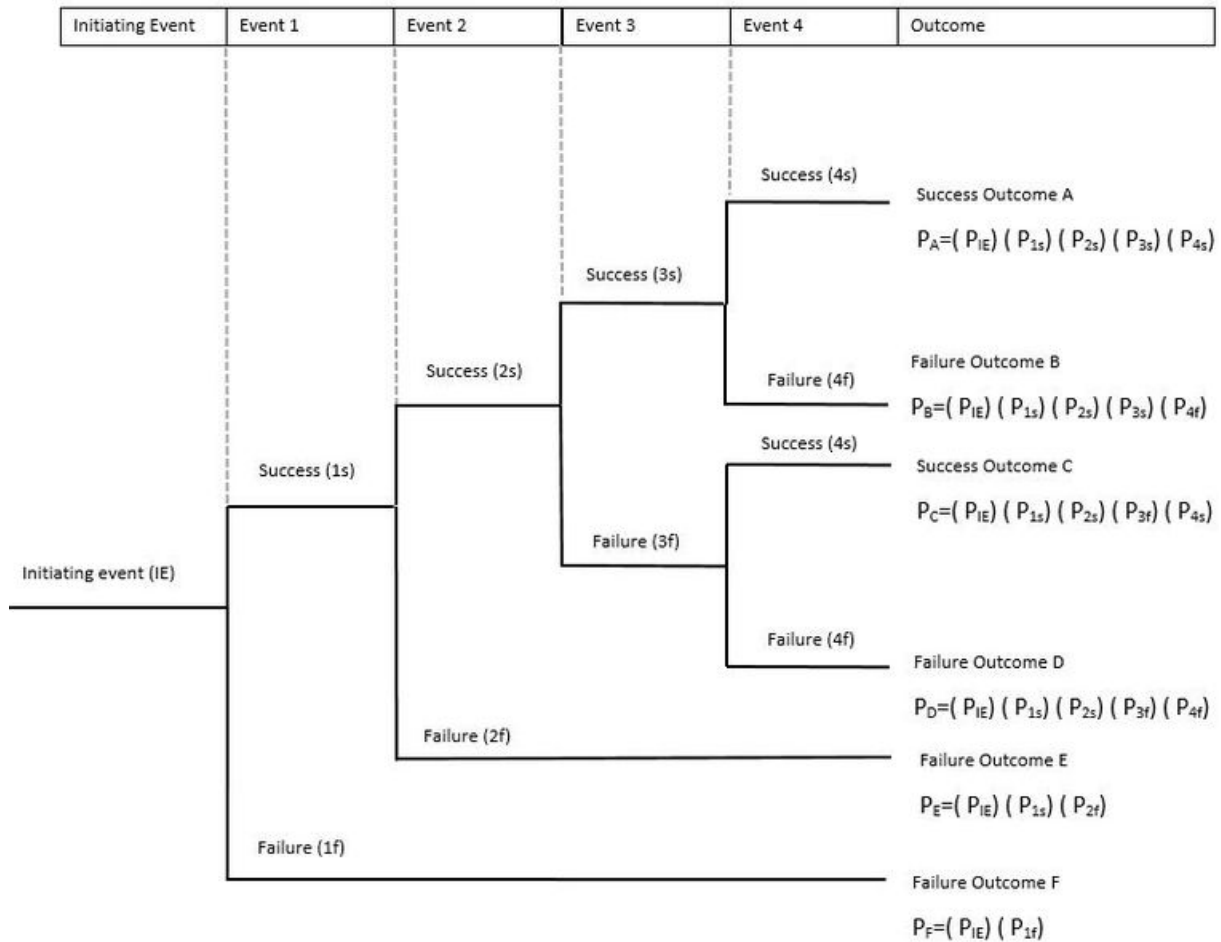

Figure 1.6 Event tree diagram example

1.7.4. Petri Net Analysis

A Petri net, also known as a place/transition (PT) net, is one of several mathematical modeling languages for the description of distributed systems. It is a class of discrete event dynamic system. A Petri net is a directed bipartite graph that has two types of elements, places and transitions, depicted as white circles and rectangles, respectively. A place can contain any number of tokens, depicted as black circles. A transition is enabled if all places connected to it as inputs contain at least one token[9, 61].

A Petri net consists of places, transitions, and arcs. Arcs, specifying the interconnection of places and transitions thus indicating which objects are changed by a certain activity. The places from which an arc runs to a transition are called the input places of the transition; the places to which arcs run from a transition are called the output places of the transition. Graphically, places in a Petri net may contain a discrete number of marks called tokens. Any distribution of tokens over the places will represent a configuration of the net called a marking. In an abstract sense relating to a Petri net diagram, a transition of a Petri net may fire if it is enabled, i.e. there are sufficient tokens in all of its input places; when the transition fires, it consumes the required input tokens, and creates tokens in its output places. A firing is atomic, i.e. a single non-interruptible step.

Consider Figure.1.7 p_1 is a place marked with one token and is connected to transition t_1 . Because of the direction of the arc connecting p_1 and t_1 we will call p_1 an input place of t_1 and t_1 accordingly an output transition of p_1 . Places and transitions might have several input/output elements. E.g., place p_2 has three input transitions: t_1 , t_3 , t_5 , while t_4 has two output places: p_4 and p_5 . The latter is marked with two tokens. p_6 and t_7 are not interconnected to any other element. Such elements will be called isolated places or transitions respectively. As expected, isolated elements of a Place-Transition net do not influence the rest of the net and therefore we can neglect them.

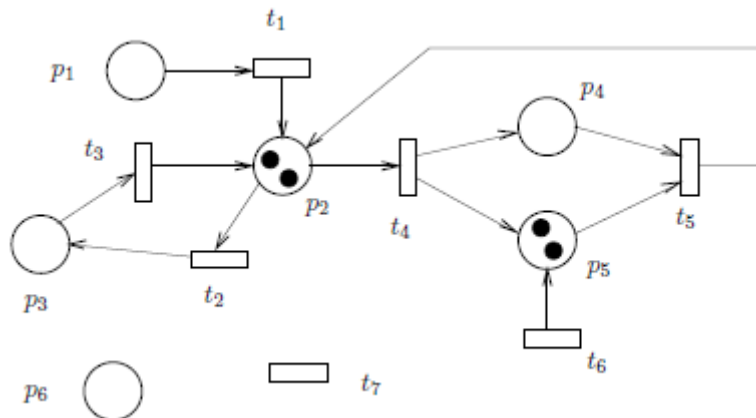

Figure 1.7 Example of a Petri net

1.7.5. Markov Analysis

Markov analysis is a stochastic technique that enables to specify the dependence of failure or repair characteristics of individual components on the state of the system. It is a technique suitable for the dependability evaluation of complex system structures and complex repair and

maintenance strategies. It should be observed that Markov analysis often represents the basis of some previously introduced formalism. The simplest Markov model is a Markov chain, which is a Markov process with a discrete state space. A Markov chain can be defined for a discrete set of times (i.e., discrete-time Markov chain-DTMC) or for time taking nonnegative real values (i.e., continuous time Markov chain-CTMC). For dependability applications, the normal reference model is the CTMC[62].

Let $Z(t)$ is a stochastic process defined over the discrete state space. $Z(t)$ is a CTMC if, given any ordered sequence of time instants $(0 < t_1 < t_2 < \dots < t_m)$, the probability of being in state $x^{(m)}$ at time t_m depends only on the state occupied by the system at the previous instant of time t_{m-1} and not on the complete sequence of state occupancies. This property, which is usually referred to as the Markov property can be rephrased by saying that the future evolution of the process only depends on the present state and not on the past. Formally, the Markov property may be written as:

$$P\langle Z(t_m) = x^{(m)} \mid Z(t_{m-1}) = x^{(m-1)}, \dots, Z(t_1) = x^{(1)} \rangle = \langle Z(t_m) = x^{(m)} \mid Z(t_{m-1}) = x^{(m-1)} \rangle \quad (1.1)$$

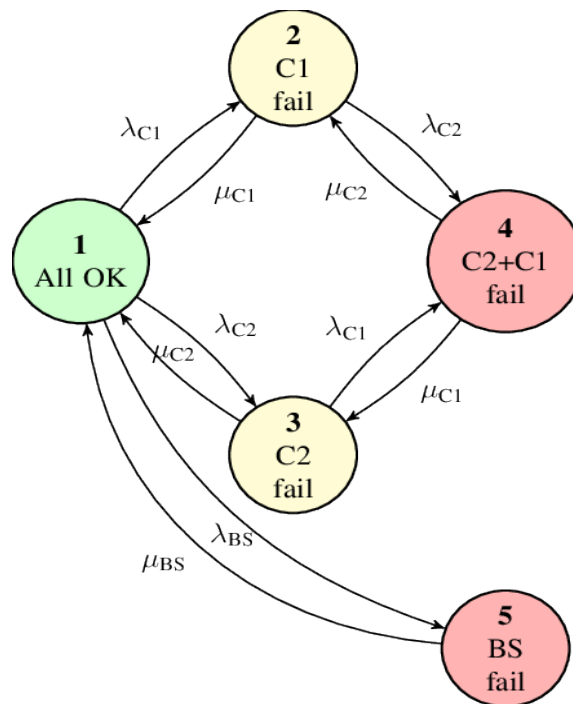

Figure 1.8 Example of a Markov graph

1.8. Limitation of risk analysis methods

Table 1.3 presents the advantages and limitations of the analytical methods selected to develop our research work.

Table 1.3 the advantages and limitations of the analytical

Method	limitations	advantages
FMECA	<ul style="list-style-type: none"> • It requires a hierarchical system drawing as the basis for the analysis, which the analyst usually has to develop before the FMEA process can start • It is optimized for mechanical and electrical equipment, and does not apply easily to Human Factor Integration, procedures or process equipment • It is difficult for the technique to cover multiple failures as equipment failures are generally analyzed one by one therefore important combinations of equipment failures may be overlooked • Most accidents have a significant human or external influence contribution and these are not a usual failure mode with FMEA • More than one FMEA may be required for a system with multiple modes of operation • Due to its wide use there can be temptation to read across data from ARM or ILS projects where, for example, the fault-tree technique has been used. As a consequence, the safety perspective can be lost as human error has 	<ul style="list-style-type: none"> • It is widely-used and well-understood, and easy to understand and interpret • It can be performed by a single analyst, or more if required • Qualitative data about the causes and effects can be incorporated into the analysis • It is systematic and comprehensive, and should identify hazards with an electrical or mechanical basis • The level of detail incorporated can be varied to suit the analysis • It identifies safety-critical equipment where a single failure would be critical for the system • Even though the technique can be quite time consuming it can lead to a thorough understanding of the system being considered

Chapter I: Literature review on analysis by dependability

	<p>been excluded and the focus has been solely on determining faults and on not on more far-reaching safety issues</p> <ul style="list-style-type: none"> • Perhaps the worst drawback of the technique is that all component failures are examined and documented, including those, which do not have any significant consequences. • For large systems, especially those with a fair degree of redundancy built into them, the amount of unnecessary documentation is a major disadvantage. Hence, the FMECA should primarily be used by designers of reasonably simple systems. It should however be noted that the concept of the FMECA form can be quite useful in other contexts, e.g. when reviewing an operation rather than a hardware system. Then the use of a form similar to the FMECA can provide a useful way of documenting the analysis. Suitable columns in the form could for example include; operation, deviation, consequence, correcting or reversing action, etc. 	
FTA	<ul style="list-style-type: none"> • The diagrammatic format discourages analysts from stating explicitly the assumptions and conditional probabilities for each gate. This can be overcome by careful back- 	<ul style="list-style-type: none"> • It is suitable for considering the many hazards that arise from a combination of adverse circumstances • It allows for the identification of common

Chapter I: Literature review on analysis by dependability

	<p>up text documentation.</p> <ul style="list-style-type: none"> • FTA can be come time-consuming and complicated for large systems • The technique examines only one specific top event. Additional FTAs must be developed to analyze other top events • Analysts may overlook failure modes and fail to recognize common cause failures (i.e. a single fault affecting two or more safeguards) unless they have a high level of expertise and work jointly with the operator • Manual FTA assumes all events are independent however the more sophisticated computer software packages can cater for the combination of events • Due to its wide use there can be temptation to read across data from ARM or ILS projects where, for example, the fault-tree technique has been used. As a consequence, the safety perspective can be lost as human error has been excluded and the focus has been solely on determining faults and on not on more far-reaching safety issues 	<p>mode or common cause failures which may not be apparent when considering sub-systems in isolation</p> <ul style="list-style-type: none"> • It is often the only technique that can generate credible likelihoods for novel, complex systems • Human errors can be included in the analysis • It can be used both qualitatively and quantitatively depending on what is required from the analysis • It a clear and logical form of presentation to non-specialist users provided an appropriate of the tree is used. • The technique is widely used and well accepted and can be used for cross-discipline system analysis
--	--	--

1.9. Criteria for choosing a risk analysis method

We have retained most of the criteria weighing in the implementation of one method rather than another in the study of a given system:

- Field of study.
- Study stage (specification, design... dismantling).

Chapter I: Literature review on analysis by dependability

- Perception of risk in this field.
- Organizational dependability culture.
- Characteristics of the problem to be analyzed.
- Envisaged level of security demonstration.
- Nature of the information available (specifications of the system and its interfaces, constraints, etc.).
- Experience feedback and database available.
- Human, logistical and other resources.
- Deadlines and other project management constraints.

However, the separate use of a single risk analysis method may not provide a definitive demonstration of the achievement of safety objectives. Indeed, it is necessary to combine several methods for better completeness and good consistency in terms of results.

1.10. Conclusion

In the context of this chapter, we have introduced precise definitions characterizing the various attributes of systems dependability. A major strength of the dependability concept, as it is formulated in this chapter, is its integrative nature, that enables to put into perspective the more classical notions of reliability, availability, safety, maintainability, that are then seen as attributes of dependability. Then we have tried to better situate the approaches and methods of risk analysis; we first clarified the reasoning techniques for predictive risk analysis where we presented the difference between the methods qualitative / quantitative and static / dynamic. Then, the methods most used in the analysis of dependability were defined with the process of their operations. After the identification of the advantages and limitations of the analysis methods chosen for the development of our research work, we found it interesting to then propose the criteria for choosing a risk analysis method.

In the following chapter we will try to classify the existing category which applied different methods to enhance FMECA performance and provide a direction for our research so as to further solve the known deficiencies of the traditional FMECA.

Chapter II

Criticality evaluation in FMECA method of the industrial risks

2.1. INTRODUCTION

The industrial risk problematic and the diversification of risk types have increased consequently with the industrial development. In the same time, the risk acceptability threshold of the population has decreased. In response to this preoccupation, competent authorities and industrialists have developed methodologies and tools for risk prevention and protection, as well as crisis management. To face up to major accidents, a previous analyze should be done. The forward-looking risk analysis allows doing an exhaustive identification of potential hazardous sources to prevent accident scenarios and to assess potential impact on human, environmental and equipment targets in order to propose prevention or protection. The risk analysis methodologies focus on the main hazard sources.

Vast majority of risk priority models are found in the literature to improve the criticality analysis process of FMECA. Therefore we propose a framework for classifying the reviewed tools and methodology depending upon the failure mode evaluation and prioritization, we divide the methods used in into two main categories which are multi-criteria decision making (MCDM), and Artificial intelligence approaches (AI).

2.2. Multi-criteria decision making approaches (MCDM)

As a well-known branch of operation research, the MCDM methods have been extensively used by researchers to improve the performance of FMECA and are considered as a valuable tool in handling the drawbacks related to the conventional RPN method. According to the MCDM methods employed in the determination of risk priority of failure modes in FMECA we adopted on the pair wise comparison methods (AHP) and the grey relational analysis (GRA) Distance-based methods[63, 64].

2.2.1. Pairwise comparison methods

As a pairwise comparison MCDM method, the analytic hierarchy process (AHP) (Saaty, 1977 and 1980) is a one of the multiple criterion evaluation methodology that is both descriptive and prescriptive. The Analytic Hierarchy Process (AHP) is, in many ways, similar to Multi Attribute Utility Theory. However, unlike MAUT, AHP does not prescribe that judgments be perfectly consistent, nor does it prescribe when or when not to allow for rank

Chapter II: Criticality evaluation in FMECA method of the industrial risks

reversals. AHP allows the decision makers to decide how much inconsistency is reasonable, if any, and whether or not rank reversal (a reflection of relative rather than absolute worth) should be permitted.

2.2.1.1. The analytic hierarchy process (AHP)

Analytical Hierarchy Process is one of the most inclusive systems considered to make decisions with multiple criteria because this method gives to formulate the problem as a hierarchical and believe a mixture of quantitative and qualitative criteria as well[65].

AHP is comprised of a few powerful and widely accepted concepts:

- Structuring complexity in a hierarchy
- Making pairwise, relative comparisons
- Using redundancy of judgments to improve accuracy and deal with «fuzziness».

2.2.1.1.1 Steps to Conduct AHP

AHP models are generally composed of the highest level (goal layer), several intermediate levels (criterion layers) and the alternatives levels (index layers). In the AHP model, different basic factors belong to several layers from top to bottom.

In the AHP structure, the judgment matrix is a notably important term, which is formed by comparing any two basic factors and metricating the factors. There are various scaling methods, and the generally used one is the 1–9 scale method, as shown in Table 2.1. The specific steps are explained in detail in the following sections[66].

- Step 1: development of the hierarchy structure where the goal lies at the top of the hierarchy; the next two tiers typically include the criterion, while alternatives appear at the bottom of the hierarchy figure 2.1.

Chapter II: Criticality evaluation in FMECA method of the industrial risks

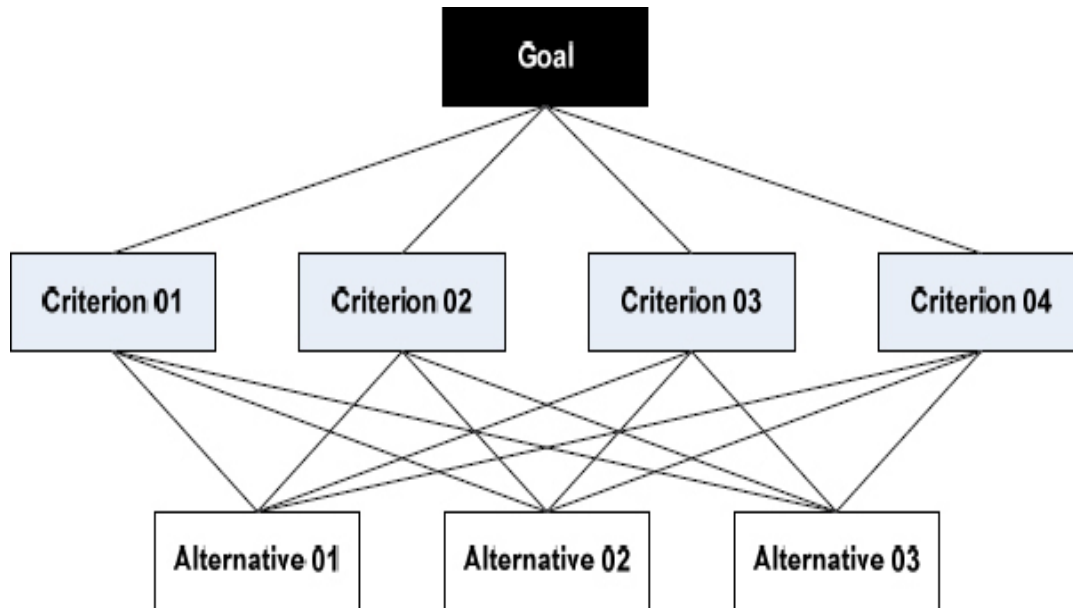

Figure 2.1 Hierarchy structure of the AHP method

- Step 2 :make a quadratic matrix of a decision in order to compare of all elements belonging to the same hierarchical level (criticalities and decisions), while respecting the elements in the higher level by determining the importance of each one to another according to the comparison scale shown in table 2.1 (assume that a_{ij} is the value of the relative importance between the elements i and j so $a_{ij} = 1$ and $a_{ji} = 1 / a_{ij}$)

$$A = \begin{bmatrix} a_{11} & a_{12} & a_{13} & \dots & a_{1n} \\ a_{21} & a_{22} & a_{23} & \dots & a_{2n} \\ a_{31} & a_{32} & a_{33} & \dots & a_{3n} \\ \vdots & \vdots & \vdots & & \vdots \\ a_{n1} & a_{n2} & a_{n3} & \dots & A_{nn} \end{bmatrix} \quad (2.1)$$

Table 2.1AHP comparison scale

Intensity of importance	Definition
1	Equal importance
3	Moderate importance
5	Essential importance
7	Very strong importance
9	Extreme importance
2, 4, 6,8	Intermediate values

Chapter II: Criticality evaluation in FMECA method of the industrial risks

- Step 3: this step consists of determining priorities by calculating the relative importance of each element of the hierarchy from the evaluation obtained in the previous step, to determine a new matrix B.

$$B = \begin{bmatrix} \frac{1}{\sum_{i=1}^n a_{i1}} & \frac{a_{12}}{\sum_{i=1}^n a_{i2}} & \frac{a_{13}}{\sum_{i=1}^n a_{i3}} & \dots & \frac{a_{1n}}{\sum_{i=1}^n a_{in}} \\ \frac{a_{21}}{\sum_{i=1}^n a_{i1}} & \frac{1}{\sum_{i=1}^n a_{i2}} & \frac{a_{23}}{\sum_{i=1}^n a_{i3}} & \dots & \frac{a_{2n}}{\sum_{i=1}^n a_{in}} \\ \vdots & \vdots & \vdots & \vdots & \vdots \\ \frac{a_{n1}}{\sum_{i=1}^n a_{i1}} & \frac{a_{n2}}{\sum_{i=1}^n a_{i2}} & \frac{a_{n3}}{\sum_{i=1}^n a_{i3}} & \dots & \frac{1}{\sum_{i=1}^n a_{in}} \end{bmatrix} \quad (2.2)$$

The relative weight of an element i in column j of matrix B is calculated by the following equation:

$$p_{ij} = \frac{1}{\sum_{i=1}^n a_{ij}} \begin{bmatrix} a_{1j} \\ a_{2j} \\ \vdots \\ a_{nj} \end{bmatrix} \quad (2.3)$$

For each matrix, a so-called local priority vector is calculated by applying equation 2.4:

$$p_i = \frac{1}{n} \sum_{j=1}^n p_{1j} \quad (2.4)$$

The consistency is evaluated by using consistency index (CI) given by the following formula:

$$CI = \frac{TC_{\max} - K}{K - 1} \quad (2.5)$$

With: k the number of elements compared and TC the mean consistency value.

Likewise, a consistency ratio (CR) is defined and can be interpreted as the probability that the matrix B is randomly modified according to the number of criteria and a random index (RI).

$$CR = \frac{CI}{RI} \quad (2.6)$$

Chapter II: Criticality evaluation in FMECA method of the industrial risks

According to Saaty, the ratings must be revised in the event that CR exceeds 0.1

The random index (RI) is given in the appendix A.

- Step 4: the final step of the AHP is to synthesize all weights; i.e., to multiply the alternatives' priorities by the corresponding criterion weight, then appraising the results to obtain the final composite priorities of the alternatives. The highest value of the priority vector indicates the best-ranked alternative.

2.2.1.2. Fuzzy Analytic Hierarchy Process

AHP is an effective method for resolving problems of decision. It ranks the importance of criteria using pair-wise comparisons. Buckley combined the AHP into fuzzy theory, called Fuzzy AHP. In fuzzy AHP, to respond with ambiguity and subjectivity in pair-wise comparison, the ability of AHP has been improved. Instead of a crisp value, fuzzy AHP utilizes a domain of values to combine the decision maker's uncertainties[67]. The Fuzzy Analytic Hierarchy process procedure is presented as follows:

- Step 1: A pair-wise comparison matrix is created, as shown in equation 2.7. Using expert questionnaires, the expert is requested to give linguistic variables to pair-wise comparisons across all criteria using triangular fuzzy numbers figure 2.2.

$$\begin{bmatrix} (1,1,1) & a_{12} & a_{13} \\ \frac{1}{a_{12}} & (1,1,1) & a_{23} \\ \frac{1}{a_{13}} & \frac{1}{a_{23}} & (1,1,1) \end{bmatrix} \quad (2.7)$$

Where $i,j=1,2,\dots,n$

A is a Fuzzy number (g, l, m)

For reciprocal $A^{-1} = (g, l, m)^{-1} = (\frac{1}{m}, \frac{1}{l}, \frac{1}{g})$

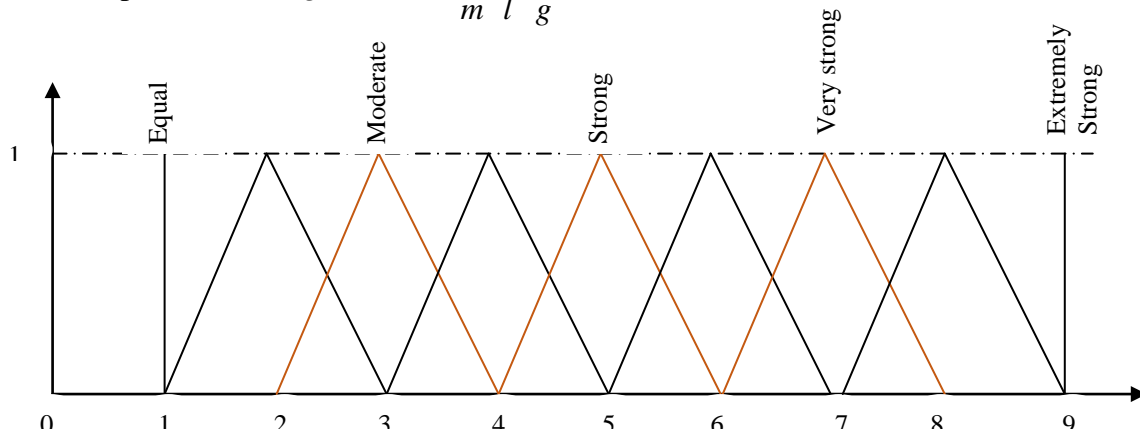

Figure 2.2 Fuzzy triangular membership functions

Chapter II: Criticality evaluation in FMECA method of the industrial risks

- Step 2: For each criterion, compute the fuzzy geometric mean as shown in equation 2.8.

$$\begin{aligned} r_i : A1 \otimes A2 \otimes \dots \otimes An &= (g1, l1, m1) \otimes (g2, l2, m2) \otimes \dots \otimes (gn, ln, mn) \\ &= (g1 * g2 * \dots * gn, l1 * l2 * \dots * ln, m1 * m2 * \dots * mn)^{1/n} \end{aligned} \quad (2.8)$$

- Step 3: Normalization is used to calculate the fuzzy weights. Equation can be used to calculate the fuzzy weight of the i^{th} criteria:

$$w_i = r_i \otimes (r1 \oplus r2 \oplus \dots \oplus rn)^{-1} \quad (2.9)$$

Where the weight's center of area (COA) is calculate as: $w_i = \frac{g + l + m}{3}$, and

$$\text{Normalized weights} = \frac{w_i}{\sum_{i=1}^n w_i}$$

2.2.2. Distance-based methods (the grey relational analysis (GRA))

Grey System theory was introduced to science world by Deng widely in (1982) has been widely used to solve the uncertainty problems under the discrete data and information incompleteness. In addition, GRA method is one of the very popular methods to analyze various relationships among the discrete data sets and make decisions in multiple attribute situations. Grey Relational Analysis is also used for decision making in multi attribute cases. The major advantages of Grey Relational Analysis are based on original data, easy calculations and being straightforward and one of the best methods to decide in business environment. Grey Relational Analysis compares the factors quantitatively in a dynamic way using information from the Grey System. This approach contacts establish relations among the factors based on level of similarity and variability[68].

2.2.2.1 The main procedure of the grey relational analysis

2.2.2.1.1 Recognizing Comparative Series

The comparative series is an information series that includes values for the different parameters. The comparative series is presented as follow:

$$z_i(m) = (z_i(1), z_i(2), z_i(3), \dots, z_i(m)) \in z, i = 1, 2, 3, \dots, n \quad (2.10)$$

Where m denotes the criticality factors number and n is the failure modes number. $z_i(m)$ indicates the m^{th} factors of z_i and the n information series is presented as follows:

Chapter II: Criticality evaluation in FMECA method of the industrial risks

$$z = \begin{bmatrix} z_1 \\ z_2 \\ \cdot \\ \cdot \\ z_n \end{bmatrix} \begin{bmatrix} z_1(1) & z_1(2) & \dots & z_1(m) \\ z_2(1) & z_2(2) & \dots & z_2(m) \\ \cdot & \cdot & & \cdot \\ \cdot & \cdot & & \cdot \\ z_n(1) & z_n(2) & \dots & z_n(m) \end{bmatrix} \quad (2.11)$$

2.2.2.1.2. Standard series identification

The objective of identifying the standard series is to deduce the degree of relation; it represents the optimal level of all decision parameters. Standard series can be explained as follows:

$$z_0(m) = (z_0(1), z_0(2), \dots, z_0(m)) = (1, 1, \dots, 1) \quad (2.12)$$

2.2.2.1.3. Obtain the difference between comparative and standard series

$$\Delta_{0i}(m) = \begin{bmatrix} \Delta_{01}(1) & \Delta_{01}(2) & \dots & \Delta_{01}(m) \\ \Delta_{02}(1) & \Delta_{02}(2) & \dots & \Delta_{02}(m) \\ \cdot & & & \cdot \\ \cdot & & & \cdot \\ \Delta_{0n}(1) & \Delta_{0n}(2) & \dots & \Delta_{0n}(m) \end{bmatrix} \quad (2.13)$$

Where $z_0(m)$ is the standard series, $z_i(m)$ is the comparative series, and $\Delta_{0i}(m) = |z_0(m) - z_i(m)|$

2.2.2.1.4. Compute the Grey Relationship Coefficient

The different parameters are compared to the standard series. The Grey relational coefficient for factors is calculated as follows:

$$\gamma(z_0(m), z_i(m)) = \frac{\Delta_{\min} + \zeta \Delta_{\max}}{\Delta_{0i}(m) + \zeta \Delta_{\max}} \quad (2.14)$$

ζ Is a predefined coefficient and is commonly used 0.5.

2.2.2.1.5. Integrate the weighted factors to determine the degree of relation

If each factor has equal importance equation (2.15) is used to determine the degree of relation:

$$\tau_i(m) = \frac{1}{n} \sum_{m=1}^n \Delta_i(m) \quad (2.15)$$

If the parameters have different importance:

Chapter II: Criticality evaluation in FMECA method of the industrial risks

$$\tau_i(m) = \sum_{m=1}^n \Delta_i(m)\beta(m)..and \sum_{m=1}^n \beta(m) = 1 \quad (2.16)$$

Where $\beta(m)$ denotes the factor weights. To calculate the risk factor weights, fuzzy AHP Process was utilized in the next stage.

2.2.2.1.6. Priority Ranking

The stronger the degree of relation, the smaller is the effect of the cause

2.3. Artificial intelligence approaches

Artificial intelligence is the science and engineering of making intelligent machines, especially intelligent computer programs. It is related to the similar task of using computers to understand human intelligence. Researchers have extensively used artificial intelligence models to improve the FMECA performance, and they are regarded as a valuable tool for dealing with the shortcomings associated with the traditional RPN method.

2.3.1. Fuzzy LOGIC

In recent years, the number and variety of fuzzy logic applications have increased significantly. The applications range from consumer products such as cameras, camcorders, washing machines, and microwave ovens to industrial process control, medical instrumentation, decision-support systems.

Fuzzy logic has two different meanings. In a narrow sense, fuzzy logic is a logical system, which is an extension of multivalued logic. However, in a wider sense fuzzy logic (FL) is almost synonymous with the theory of fuzzy sets, a theory which relates to classes of objects with unsharp boundaries in which membership is a matter of degree. In this perspective, fuzzy logic in its narrow sense is a branch of FL. Even in its more narrow definition, fuzzy logic differs both in concept and substance from traditional multivalued logical systems.

In effect, much of FL may be viewed as a methodology for computing with words rather than numbers. Although words are inherently less precise than numbers, their use is closer to human intuition. Furthermore, computing with words exploits the tolerance for imprecision and thereby lowers the cost of solution

2.3.1.1 Basic Definitions and Terminology

Let X is a space of objects and x is a generic element of X . A classic set A , $A \subseteq X$ is defined as a collection of elements or objects $x \in X$, such that each x can either belong to or not belong to the set A . By defining a characteristic function for each element x in X , we can

Chapter II: Criticality evaluation in FMECA method of the industrial risks

represent a classical set A by a set of ordered pairs $(x, 0)$ or $(x, 1)$, which indicates $x \notin A$ or $x \in A$, respectively.

Unlike the classical set, a fuzzy set expresses the degree to which an element belongs to a set. Hence the characteristic function of a fuzzy set is allowed to have values between 0 and 1, which denotes the degree of membership of an element in a given set.

If X is a collection of objects denoted generically by x , then a fuzzy set A in x is defined as a set of ordered pairs:

$$A = \langle (x, \mu_A(x)) \mid x \in X \rangle \quad (2.17)$$

Where $\mu_A(x)$ is called the membership function (MF) for the fuzzy set A . The MF maps each element of x to a membership value between 0 and 1. It is obvious that if the value of the membership function $\mu_A(x)$ is restricted to either 0 or 1, then A is reduced to a classical set and $\mu_A(x)$ is the characteristic function of A . Usually X is referred to as the universe of discourse, or simply the universe, and it may consist of discrete (ordered or unordered) objects or continuous space.

The construction of a fuzzy set depends on two things: the identification of a suitable universe of discourse and the specification of an appropriate membership function. Therefore, the subjectivity and non-randomness of fuzzy sets is the primary difference between the study of fuzzy sets and probability theory.

In practice, when the universe of discourse X is a continuous space, we usually partition X into several fuzzy sets whose MFs cover x in a more or less uniform manner. These fuzzy sets, which usually carry names that conform to adjectives appearing in our daily linguistic usage, such as “large,” “medium,” or “negative” are called linguistic values or linguistic labels. In general, a linguistic variable with universe of discourse X may take on several linguistic values. The set of linguistic values is referred to as the term set of the linguistic variable. Since each linguistic value is a fuzzy set on X , the term set represents a fuzzy partitioning of X , where the membership functions of the linguistic values are made to overlap.

2.3.1.2 Membership Functions (MF)

As discussed above a fuzzy set is completely parameterized by its MF. Since most fuzzy sets have a universe of discourse X consisting of the real line R , it would be impractical to list all the pairs defining a membership function. So a MF is expressed with the help of a mathematical formula. A MF can be parameterized according to the complexity required.

Chapter II: Criticality evaluation in FMECA method of the industrial risks

These also could be one dimensional or multi dimensional. Here are a few classes of parameterized MFs of one dimension that is MFs with a single input[69, 70].

2.3.1.2.1. Triangular Membership Function

A triangular MF is specified by three parameters $\{a, b, c\}$ as follows

$$f(x; a, b, c) = \left\{ \begin{array}{l} 0, \dots \dots \dots x \leq a \\ \frac{x-a}{b-a} \dots \dots \dots a \leq x \leq b \\ \frac{c-x}{c-b} \dots \dots \dots b \leq x \leq c \\ 0, \dots \dots \dots c \leq x \end{array} \right\} \quad (2.18)$$

The parameters $\{a, b, c\}$ (with $a < b < c$) determine the x coordinates of the three corners of the underlying triangular MF.

2.3.1.2.2. Trapezoidal Membership Function

A trapezoidal MF is specified by four parameters $\{a, b, c, d\}$ as follows

$$s(x; a, b, c, d) = \left\{ \begin{array}{l} 0, \dots \dots \dots x \leq a \\ \frac{x-a}{b-a} \dots \dots \dots a \leq x \leq b \\ 1, \dots \dots \dots b \leq x \leq c \\ \frac{d-x}{d-c} \dots \dots \dots c \leq x \leq d \\ 0, \dots \dots \dots d \leq x \end{array} \right\} \quad (2.19)$$

The parameter $\{a, b, c, d\}$ (with $a < b < c < d$) determine the x coordinates of the four corners of the underlying trapezoidal MF

2.3.1.2.3. Gaussian Membership Function

A Gaussian MF is specified by two parameters $\{c, \sigma\}$

$$f(x, \sigma, c) = \exp\left(\frac{-0.5(x-c)^2}{\sigma^2}\right) \quad (2.20)$$

A Gaussian MF is determined completely by c and σ ; c represents the MFs center and determines the MFs width

2.3.1.2.4. Generalized Bell Membership Function

A generalized bell MF (or bell MF) is specified by three parameters $\{a, b, c\}$

$$bell(x, a, b, c) = \frac{1}{1 + \left| \frac{x-c}{a} \right|^{2b}} \quad (2.21)$$

Chapter II: Criticality evaluation in FMECA method of the industrial risks

Where the parameter b is usually positive. It is also called as the Cauchy MF.

2.3.1.2.5. Sigmoid Membership Function

A sigmoid MF is defined by

$$\text{sig}(x; a; c) = \frac{1}{1 + \exp[-a(x - c)]} \quad (2.22)$$

Where a controls the slope at the crossover point $x=c$. Sigmoid functions are widely used as the activation function of artificial neural networks.

2.3.1.3. Linguistic Variables and Fuzzy If-Then Rules

In 1973, Professor Lotfi Zadeh proposed the concept of linguistic or "fuzzy" variables. Think of them as linguistic objects or words, rather than numbers. The sensor input is a noun, e.g. "temperature," "displacement," "velocity," "flow," "pressure," etc. Since error is just the difference, it can be thought of the same way. The fuzzy variables themselves are adjectives that modify the variable (e.g. "large positive" error, "small positive" error, "zero" error, "small negative" error, and "large negative" error). As a minimum, one could simply have "positive", "zero", and "negative" variables for each of the parameters. Additional ranges such as "very large" and "very small" could also be added to extend the responsiveness to exceptional or very nonlinear conditions, but aren't necessary in a basic system[71, 72].

Once the linguistic variables and values are defined, the rules of the fuzzy inference system can be formulated. These rules map the fuzzy inputs to fuzzy outputs. This mapping takes place through compositional rule of inference which is based on Zadeh's extension of modus ponens which is nothing more than the familiar if-then conditional form. A fuzzy if-then rule (also known as fuzzy rule) assumes the form:

$$\text{If } x \text{ is } A \text{ then } y \text{ is } B \quad (2.23)$$

Where A and B are linguistic values defined by fuzzy sets on universe of discourse x and y , respectively. "x is A" is called the antecedent or premise, while "y is B" is called the consequent or conclusion. This rule is also abbreviated as $A \rightarrow B$.

2.3.1.4. Fuzzy Inference Process

There are three main fuzzy logic inference systems (fuzzy logic approximators): Mamdani type, Sugeno type, and Tsukamoto type. Of these Mamdani fuzzy inference system is used. Figure 2.3 illustrates the basic building block of the inference process[73].

Chapter II: Criticality evaluation in FMECA method of the industrial risks

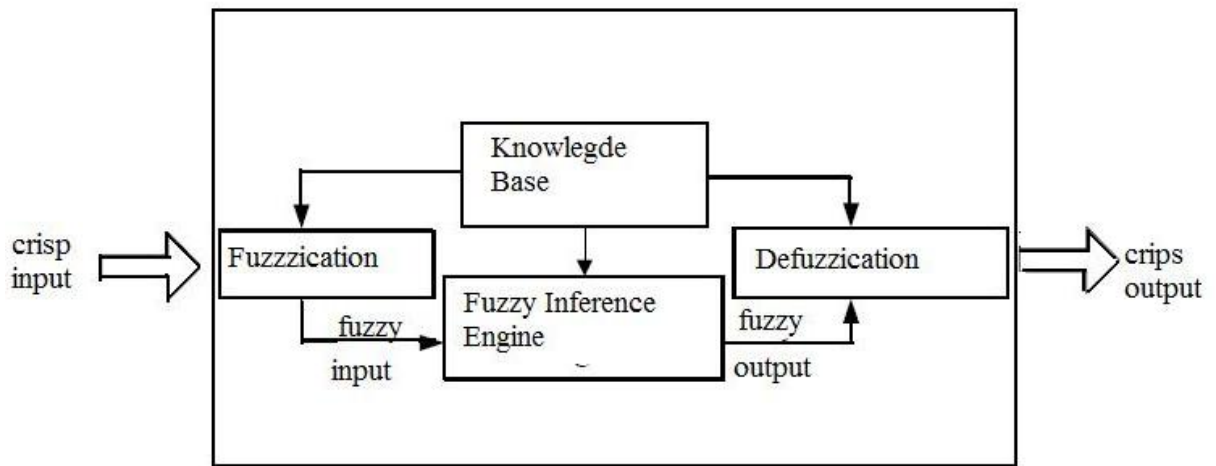

Figure 2. 3 inference systems process

2.3.1.4.1. Fuzzification

The first step is to take the inputs and determine the degree to which they belong to each of the appropriate fuzzy sets via membership functions. In Fuzzy Logic Toolbox software, the input is always a crisp numerical value limited to the universe of discourse of the input variable and the output is a fuzzy degree of membership in the qualifying linguistic set[74].

For each input, we describe a universe of discourse, a partition of this universe into classes. The fuzzification, is to allocate the membership function to each parameter's real value, i.e. to transform input data into a fuzzy set.

2.3.1.4.2. Apply Fuzzy Operator

After the inputs are fuzzified, you know the degree to which each part of the antecedent is satisfied for each rule. If the antecedent of a given rule has more than one part, the fuzzy operator is applied to obtain one number that represents the result of the antecedent for that rule. This number is then applied to the output function. The input to the fuzzy operator is two or more membership values from fuzzified input variables. The output is a single truth value.

As is described in previous section, any number of well-defined methods can fill in for the AND operation or the OR operation. In the toolbox, two built-in AND methods are supported: min (minimum) and prod (product). Two built-in OR methods are also supported: max (maximum), and the probabilistic OR method [75].

The following example figure 2.4 shows the OR operator max at work, evaluating. The two different pieces of the antecedent (service is excellent and food is delicious) yielded the fuzzy membership values 0.0 and 0.7 respectively. The fuzzy OR operator simply selects the maximum of the two values, 0.7. The probabilistic OR method would still result in 0.7.

Chapter II: Criticality evaluation in FMECA method of the industrial risks

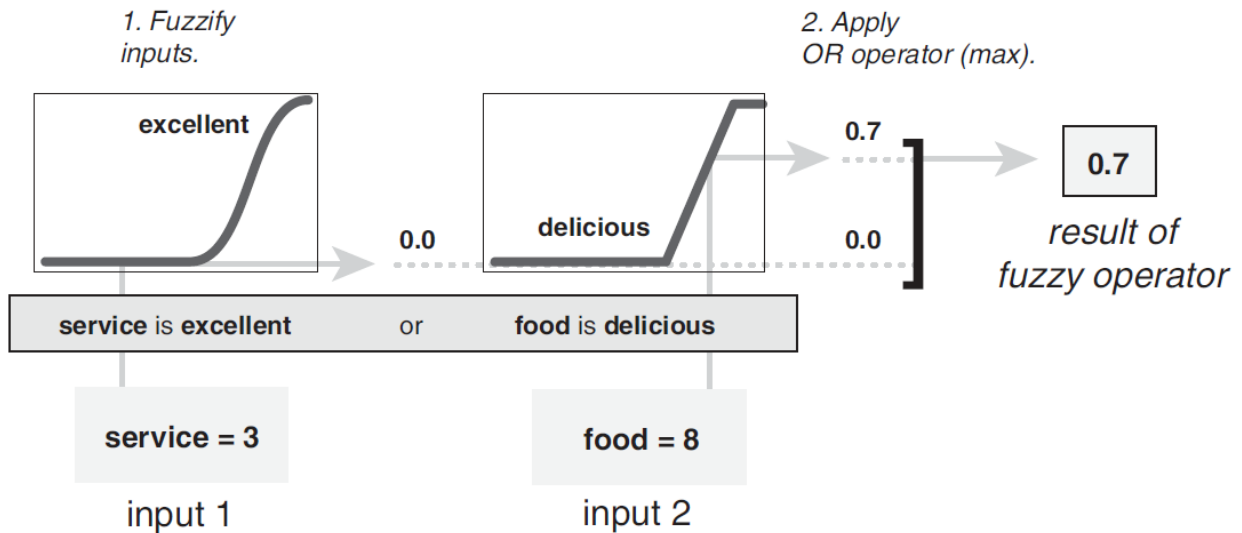

Figure 2.4 Fuzzy Operator example

2.3.1.4.3 Apply Implication Method

Before applying the implication method, you must determine the rule's weight. Every rule has a weight (a number between 0 and 1), which is applied to the number given by the antecedent. Generally, this weight is 1 (as it is for this example) and thus has no effect at all on the implication process. From time to time you may want to weight one rule relative to the others by changing its weight value to something other than 1.

After proper weighting has been assigned to each rule, the implication method is implemented. A consequent is a fuzzy set represented by a membership function, which weights appropriately the linguistic characteristics that are attributed to it. The consequent is reshaped using a function associated with the antecedent (a single number). The input for the implication process is a single number given by the antecedent, and the output is a fuzzy set. Implication is implemented for each rule. Two built-in methods are supported, and they are the same functions that are used by the AND method: min (minimum), which truncates the output fuzzy set, and prod (product), which scales the output fuzzy set.

2.3.1.4.4. Aggregate All Outputs

Because decisions are based on the testing of all of the rules in a FIS, the rules must be combined in some manner in order to make a decision. Aggregation is the process by which the fuzzy sets that represent the outputs of each rule are combined into a single fuzzy set. Aggregation only occurs once for each output variable, just prior to the fifth and final step, defuzzification. The input of the aggregation process is the list of truncated output functions

Chapter II: Criticality evaluation in FMECA method of the industrial risks

returned by the implication process for each rule. The output of the aggregation process is one fuzzy set for each output variable.

As long as the aggregation method is commutative (which it always should be), then the order in which the rules are executed is unimportant. Three built-in methods are supported:

- max (maximum)
- probor (probabilistic OR)
- sum (simply the sum of each rule's output set)

2.3.1.4.5. defuzzification

The input for the defuzzification process is a fuzzy set (the aggregate output fuzzy set) and the output is a single number. As much as fuzziness helps the rule evaluation during the intermediate steps, the final desired output for each variable is generally a single number. However, the aggregate of a fuzzy set encompasses a range of output values, and so must be defuzzified in order to resolve a single output value from the set. There are five built-in defuzzification methods supported: centroid, bisector, middle of maximum (the average of the maximum value of the output set), largest of maximum, and smallest of maximum. Perhaps the most popular defuzzification method is the centroid calculation which is defined by the following equation:

$$\text{Defuzzified value} = \frac{\int_i^{\mu} (x)xdx}{\int_i^{\mu} (x)dx} \quad (2.24)$$

When the function $\mu (C_i)$ is discredited, the center of gravity is given by:

$$C_i = \frac{\sum_{j=1}^n \mu_j C_{ij}}{\sum_{j=1}^n \mu_j} \quad (2.25)$$

The following figure 2.5 illustrates the global fuzzy inference process

Chapter II: Criticality evaluation in FMECA method of the industrial risks

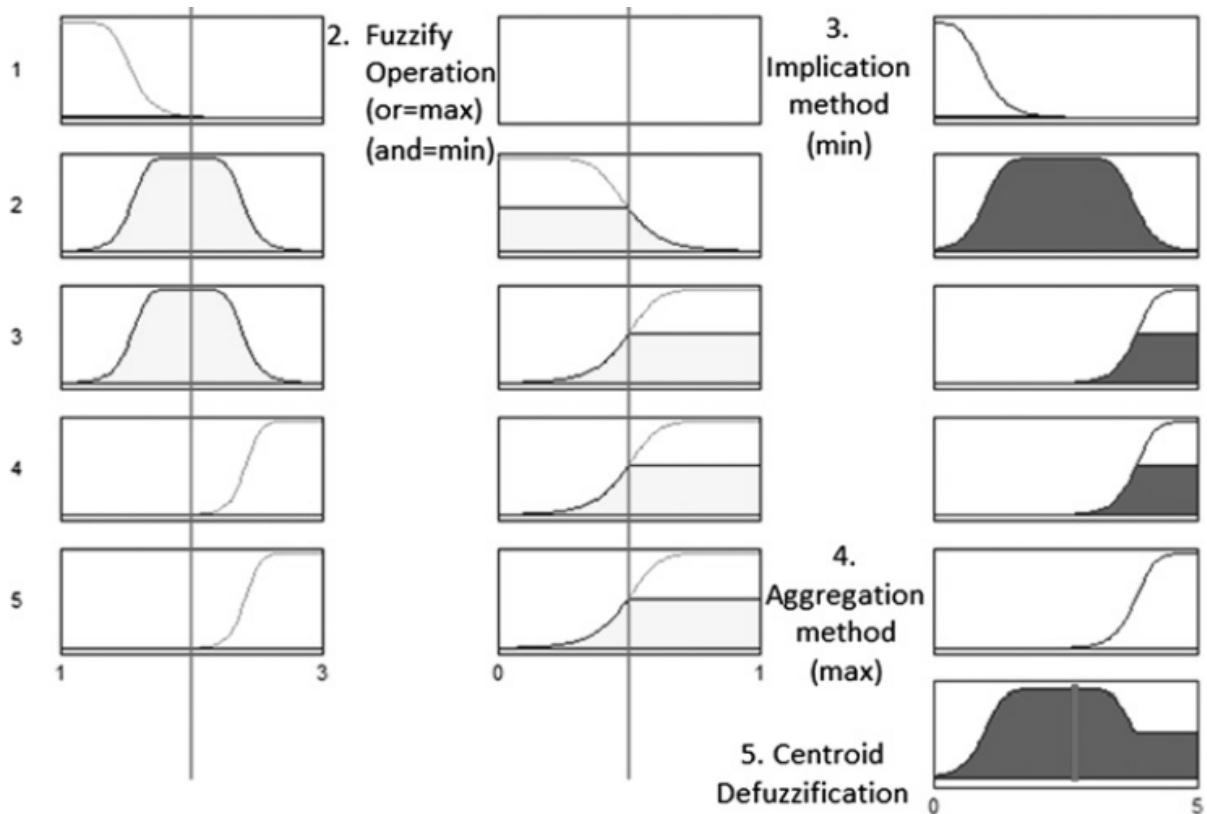

Figure 2.5 global fuzzy inference process

2.3.1.5. Why Use Fuzzy Logic

Here is a list of general observations about fuzzy logic:

- Fuzzy logic is conceptually easy to understand.
- The mathematical concepts behind fuzzy reasoning are very simple. Fuzzy logic is a more intuitive approach without the far-reaching complexity.
- Fuzzy logic is flexible.
- With any given system, it is easy to layer on more functionality without starting again from scratch.
- Fuzzy logic is tolerant of imprecise data
- Fuzzy logic can model nonlinear functions of arbitrary complexity. You can create a fuzzy system to match any set of input-output data. This process is made particularly easy by adaptive techniques like Adaptive Neuro-Fuzzy Inference Systems (ANFIS), which are available in Fuzzy Logic Toolbox software.
- Fuzzy logic can be built on top of the experience of experts.
- Fuzzy logic can be blended with conventional control techniques.
- Fuzzy logic is based on natural language

Chapter II: Criticality evaluation in FMECA method of the industrial risks

2.3.2. Development of the ANFIS Model and the structure

Among various combinations of methodologies in soft computing, the one that has highest visibility at this juncture is that of fuzzy logic and neurocomputing, leading to neuro-fuzzy systems. Within fuzzy logic, such systems play a particularly important role in the induction of rules from observations. An effective method developed by Dr. Roger Jang for this purpose is called ANFIS (Adaptive Neuro-Fuzzy Inference System). This method is an important component of the toolbox.

The adaptive neuro-fuzzy inference system is the result of combining artificial neural network (ANN) and fuzzy inference system (FIS)[76]. The latter offers a fuzzy logic technique based on rules created during the training process of the model. The input–output relationship is explained by rules derived from relevant knowledge. The training examples are used to determine the parameters of FIS's membership function. Mamdani and Sugeno are the most commonly used FISs. ANFIS uses the ANN because of its ability to classify and identify patterns. It uses a hybrid learning technique that combines a least-squares and back-propagation method. ANFIS uses neural network learning methods to adjust the parameters of the fuzzy inference system. Various characteristics make ANFIS a great success:

- It improves fuzzy IF-THEN rules in order to depict the action of a complicated system.
- The ANFIS system does not necessitate any previous human expertise.
- It allows accurate and fast learning
- It is easy to implement.
- It's simple to combine both numeric and linguistic knowledge to solve the problem

2.3.2.1. ANFIS architecture

In ANFIS the output of each rule can be a linear combination of input variables plus a constant term or can be only a constant term. The final output is the weighted average of each rule's output. It is assumed that there are two inputs in order to comprehend basic rule construction. y and z , and one output as shown in figure 2.6. According to sugeno's first-order model, two fuzzy if–then rules are presented as follows:

$$\text{Rule 1 : If } y \text{ is } K_1 \text{ and } z \text{ is } N_1, \text{ then } f_1 = p_{1y} + q_{1z} + r_1$$

$$\text{Rule 2 : If } y \text{ is } K_2 \text{ and } z \text{ is } N_2, \text{ then } f_2 = p_{2y} + q_{2z} + r_2$$

Where y and z are the inputs, K_i and N_i are the fuzzy sets, while q_i , p_i , and r_i are output parameters. The structure of the ANFIS system consists of five layers in order to train Sugeno-

Chapter II: Criticality evaluation in FMECA method of the industrial risks

type FIS. The objective is to make the output of ANFIS match the training data by adjusting parameters. The layers are defined in the following paragraphs[77].

Fuzzification layer (Layer 1): The membership functions of input variables are included in this layer, and the output is used as the input for the next layer. Each node is multiplied in this context.

$$O_{1,i} = \mu_{K_i}(y); i = 1,2 \quad (2.26)$$

$$O_{1,i} = \mu_{N_i}(z); i = 3,4$$

Where y and z are the inputs to node i, and K_i and N_i are the labels linguistic (low, remote, moderate...) related with $\mu_{K_i}(y)$; and $\mu_{N_i}(z)$.

The rule layer (Layer 2): this layer is known as the rule's firing strength and can be defined as:

$$w_i = \mu_{K_i}(y) \times \mu_{N_i}(z), i = 1,2 \quad (2.27)$$

Where w_i indicates a rule's firing strength.

Normalization layer (Layer 3): the firing strength rules are normalized in this layer to assess the difference between the overall firing strengths of all rules and the firing strengths of each rule. The outputs of this layer are known as normalized firing. The output is given as:

$$O_{3,i} = \bar{w}_i = \frac{w_i}{w_1 + w_2}, i = 1,2. \quad (2.28)$$

Defuzzification layer (Layer 4): in this layer, each node is an adaptive node with a node function. The output of this layer is a first-order polynomial and a normalized firing strength product and represented as:

$$O_{4i} = \bar{w}_i f_i = \bar{w}_i (p_i y + q_i z + r_i), i = 1,2. \quad (2.29)$$

Where \bar{w}_i the output of the third layer and f_i is is the output of the i^{th} rule.

Output layer (Layer 5): This layer represents the model's global output as the sum of all incoming signals. The global output is defined:

$$O_{5,i} = \sum_i \bar{w}_i f_i = \frac{\sum_i w_i f_i}{\sum_i w_i} \quad (2.30)$$

Chapter II: Criticality evaluation in FMECA method of the industrial risks

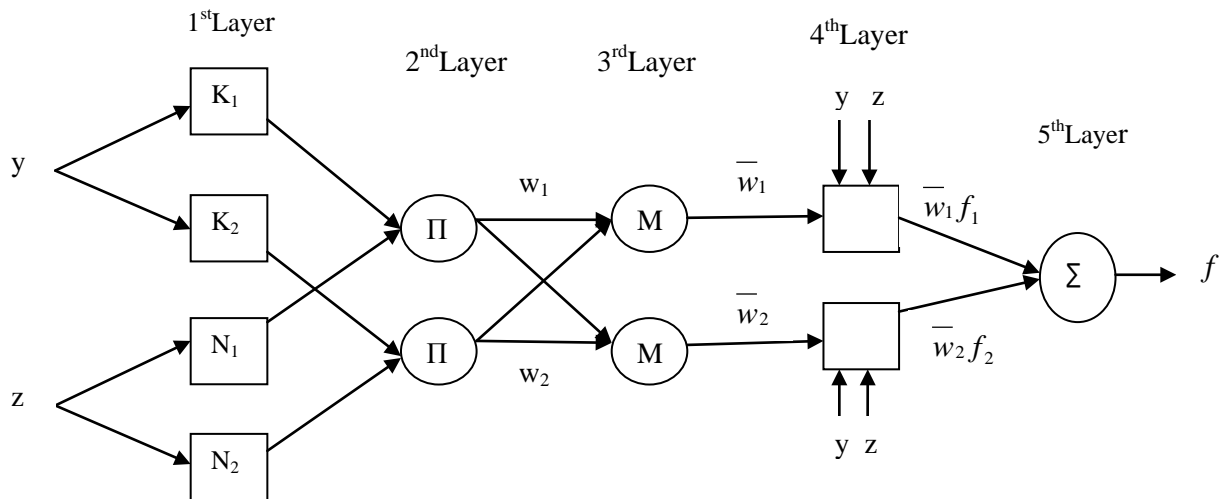

Figure 2.6 ANFIS architecture

2.3.2.2. ANFIS Process

the toolbox function ANFIS constructs a fuzzy inference system (FIS) whose membership function parameters are tuned (adjusted) using either a back propagation algorithm alone or in combination with a least squares type of method. This adjustment allows your fuzzy systems to learn from the data they are modeling. The more the rules the better the result of cost function unless there is overfitting. Over fitting occurs if there are many MF and there are a few samples so the free parameters are memorizing the previous values[78]. Hence, different methods, parameters and datasets should be applied to find the minimum RMSE for the testing dataset. The flowchart for adjusting the ANFIS shown in figure 2.7.

It starts from data collection with event data including input and output data in the form of the data array. Then, the training data will be loaded into ANFIS editor and the specified testing data will be used for further validation. The next step is initializing the fuzzy inference system (FIS) to set up the numbers and types of current MF in modeling nonlinear functions.

Chapter II: Criticality evaluation in FMECA method of the industrial risks

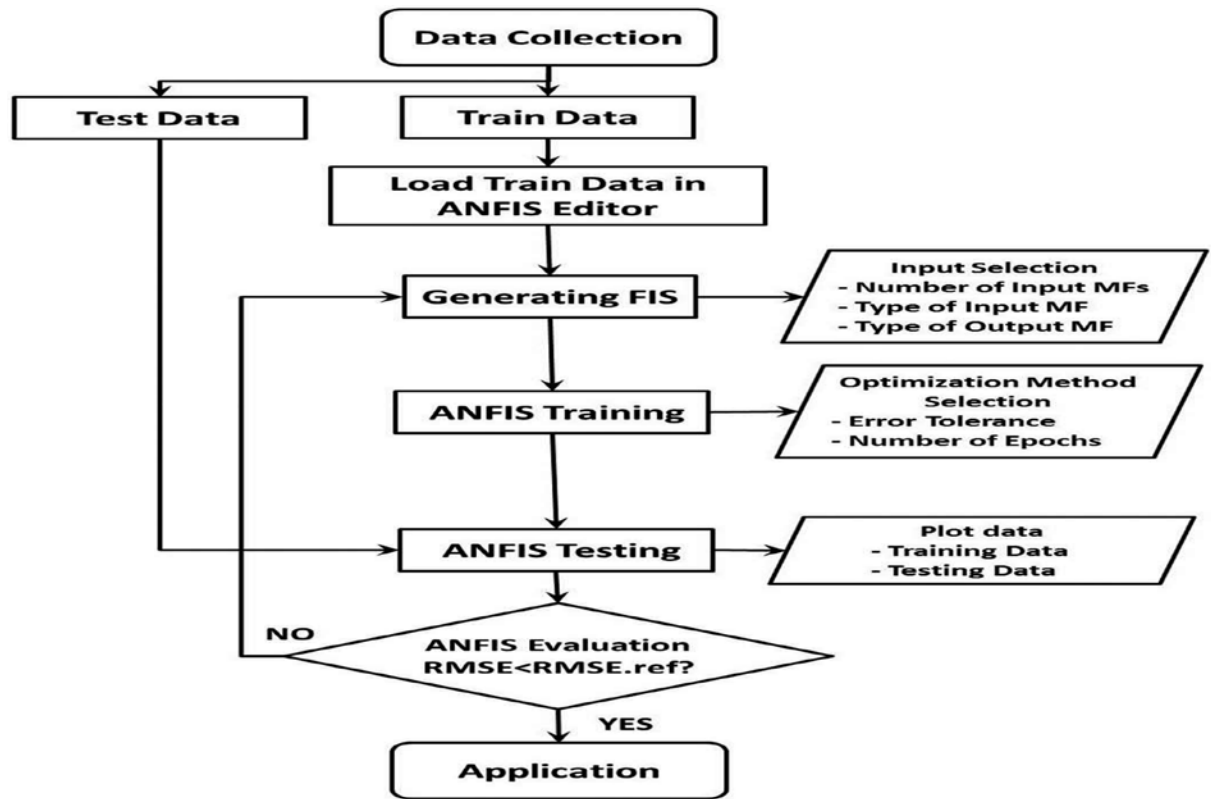

Figure 2.7 The flowchart of the ANFIS

2.3.2.2.1. Data collection

The databases selected for ANFIS training are of great importance and also determine the model accuracy and applicability. Therefore, the experimental databases used as input–output of the ANFIS model should be broad and able to representative of the problem to be solved. But the whole ranges of engine running conditions are not feasible because of the large number of parameters. Therefore, it needs a simplified collection of particular parameters

2.3.2.2.2. Training Data

The training data is a required argument to ANFIS, as well as to the Neuro- Fuzzy Designer. Each row of the training data is a desired input/output pair of the target system you want to model. Each row starts with an input vector and is followed by an output value. Therefore, the number of rows of training data is equal to the number of training data pairs, and, because there is only one output, the number of columns of the training data is equal to the number of inputs plus one.

2.3.2.2.2.1. Generating FIS Structure

Chapter II: Criticality evaluation in FMECA method of the industrial risks

The FIS structure contains both the model structure, (which specifies such items as the number of rules in the FIS, the number of membership functions for each input, etc.), and the parameters, (which specify the shapes of membership functions).

There are two methods that ANFIS learning employs for updating membership function parameters:

- Back-propagation for all parameters (a steepest descent method)
- A hybrid method consisting of back-propagation for the parameters associated with the input membership functions, and least squares estimation for the parameters associated with the output membership functions

These method choices are designated in the command line function, ANFIS, by 1 and 0, respectively. As a result, the training error decreases, at least locally, throughout the learning process. Therefore, the more the initial membership functions resemble the optimal ones, the easier it will be for the model parameter training to converge. Human expertise about the target system to be modeled may aid in setting up these initial membership function parameters in the FIS structure.

2.3.2.2.2. Training Error

The training error is the difference between the training data output value, and the output of the fuzzy inference system corresponding to the same training data input value, (the one associated with that training data output value). The training error records the root mean squared error (RMSE) of the training data set at each epoch. The Neuro-Fuzzy Designer plots the training error versus epochs curve as the system is trained.

2.3.2.2.3. Checking Data

The checking data is used for testing the generalization capability of the fuzzy inference system at each epoch. The checking data has the same format as that of the training data, and its elements are generally distinct from those of the training data[79].

The checking data is important for learning tasks for which the input number is large, and/or the data itself is noisy. A fuzzy inference system needs to track a given input/ output data set well. Because the model structure used for ANFIS is fixed, there is a tendency for the model to overfit the data on which is it trained, especially for a large number of training epochs. If overfitting does occur, the fuzzy inference system may not respond well to other independent data sets, especially if they are corrupted by noise. A validation or checking data set can be useful for these situations. This data set is used to cross-validate the fuzzy inference

Chapter II: Criticality evaluation in FMECA method of the industrial risks

model. This cross-validation requires applying the checking data to the model and then seeing how well the model responds to this data.

When the checking data option is used with ANFIS, either via the command line, or using the Neuro-Fuzzy Designer, the checking data is applied to the model at each training epoch. When the command line ANFIS is invoked, the model parameters that correspond to the minimum checking error are returned via the output argument `fismat2`. The FIS membership function parameters computed using the Neuro-Fuzzy Designer when both training and checking data are loaded are associated with the training epoch that has a minimum checking error.

The use of the minimum checking data error epoch to set the membership function parameters assumes

- The checking data is similar enough to the training data that the checking data error decreases as the training begins.
- The checking data increases at some point in the training after the data overfitting occurs

2.3.2.2.3.1. Checking Error

The checking error is the difference between the checking data output value, and the output of the fuzzy inference system corresponding to the same checking data input value, which is the one associated with that checking data output value. The checking error records the RMSE for the checking data at each epoch. The Neuro- Fuzzy Designer plots the checking error versus epochs curve as the system is trained[80].

2.4. Conclusion

Because of various limitations of the traditional FMECA, a great number of alternative risk evaluation models have been proposed for enhancing the performance FMECA during the last decade. The MCDM approaches and Artificial intelligence approaches (AI) are the most widespread methods employed to support risk evaluation and prioritization in the literature. In this chapter, we provided a comprehensive overview of these approaches for assessing and ranking failure modes and improving the use of the FMECA method.

In the next chapter we will apply the conventional failure mode effect and criticality analysis for two case studies. The results obtained will be used to enhance the FMECA method in subsequent chapters.

Chapter III

Traditional methodology of risk assessment in FMECA

3.1. INTRODUCTION

Failure mode and effects and criticality analysis (FMECA) is a widely used engineering technique for defining, identifying and eliminating known and/or potential failures, problems, errors and so on from system, design, process, and/or service before they reach the customer. The so-called failure mode is defined as the manner in which a component, subsystem, system, process, etc. could potentially fail to meet the design intent. A failure mode in one component can be the cause of a failure mode in another component. A failure cause is defined as a design weakness that may result in a failure. For each identified failure mode, their ultimate effects need to be determined, usually by a FMECA team. A failure effect is defined as the result of a failure mode on the function of the product/process as perceived by the customer[81].

A system, design, process, or service may usually have multiple failure modes or causes and effects. In this situation, each failure mode or cause needs to be assessed and prioritized in terms of their risks so that high risky (or most dangerous) failure modes can be corrected with top priority. The traditional FMECA determines the risk priorities of failure modes through the risk priority number (RPN), which is the product of the occurrence (O), severity (S) and non-detection (ND) of a failure. That is:

$$RPN = O \times S \times ND \quad (3.1)$$

To demonstrate the application of conventional FMECA method, an industrial cases study is presented in this chapter. The results obtained as a summary of this chapter will be used as the prior data for the development and improving the classical FMECA method and ameliorating the relevance of decision making of a decision support in the next chapter.

Part I (Case study 1): an industrial LPG storage system

3.2. LPG storage system

3.2.1. What is LPG?

LPG (Liquid Petroleum Gas) is a mixture of the volatile hydrocarbons like propene, propane, butene, isobutane, butane (all of them in liquid state), being in more proportion propane (C₃H₈) and Butane (C₄H₁₀). LPG is a gas at atmospheric pressure and normal ambient temperatures, but it can be liquefied when moderate pressure is applied or when the

Chapter III: Traditional methodology of risk assessment in FMECA

temperature is sufficiently reduced[82]. LPG was discovered in 1912 by Dr. Walter O. Snelling. As usual, there is a story before this discover.

3.2.2. Properties of LPG

LPG can be propane, butane or mixture of both hydrocarbures. Composition usually changes depending of the region. In those that average temperatures are high, LPG has a higher percentage of butane. In the other hand, in places where average temperatures are lower, it has a high percentage of propane. This different is due to the boiling point of both gases (-42.1°C for propane, -0.5°C for butane).

3.2.2.1. Vapour pressure

Vapour pressure is the pressure at one vapour phase is at equilibrium with its liquid phase at a given temperature. It valour it's independent of liquid and vapour amount (but it's necessary to be both phases). A lighter substance has a higher vapour pressure than heavier ones. When a mixture of substances is taken, vapour pressure has relation with temperature, but additionally, it depends of the liquid phase composition too.

3.2.2.2. Specific weight of liquid

Specific weight of a liquid it's the comparison between a given mass of a volume of a liquid at a certain temperature, with the same volume of water at that temperature.

3.2.2.3. Specific weight of vapour.

Specific weight of a vapour it's the comparison between a given mass of a volume of a vapor at a certain temperature, with the mass of the same volume of air at that temperature.

3.2.2.4. Calorific power

Calorific power it's the amount of energy (or heat) that it's liberate by a determinate amount of a substance (fuel) during the complete combustion of it.

3.2.3. Uses of LPG

It can be use in agricultural uses as: Green House Heating, flame weeding, crop drying, poultry rearing, waste incineration or distillation process, commercial uses of LPG can be like heating, refrigeration or air-conditioning, some of Industrial uses of LPG are ceramic industry, food processing industry, metal processing industry, textile industry, printing industry or chemicals production industry, it can be at mining process too. And finally, domestic uses, as cooking, heating, lighting, cooling, braining or clothes drying[83].

3.3. Identification of the systems to be studied

3.3.1. LPG Storage zone

To better estimate the contribution of the approach developed, the authors applied it to an industrial LPG storage system for ZCINA Hassi Messaoud in Algeria includes 4 pressure storage spheres (figure 3.1) with a total capacity of 500 m³ containing Liquefied Petroleum Gas stored under pressure from 15 to 21 barg, LPG will be transported by 2 centrifugal pumps to be sent to the pumping station outside the complex, the LPG storage site holds the following facilities[84]:

Access accessories: which group the following components: the staircase, the manhole, and the interior ladder.

- Control accessories: group a pressure, temperature, and level indicator.
- The operating accessories: are the different tubular placed on the lower and external part of the tanks which communicate with the inside of the tank.
- Safety accessories: these are the components and equipment that ensure the protection of the tanks against different risks.
- the TI temperature indication in the upper part of the sphere
- feed gas and residual gas pipelines including scraper stations
- a fractionation section to produce the products requested by the SONATRACH specifications

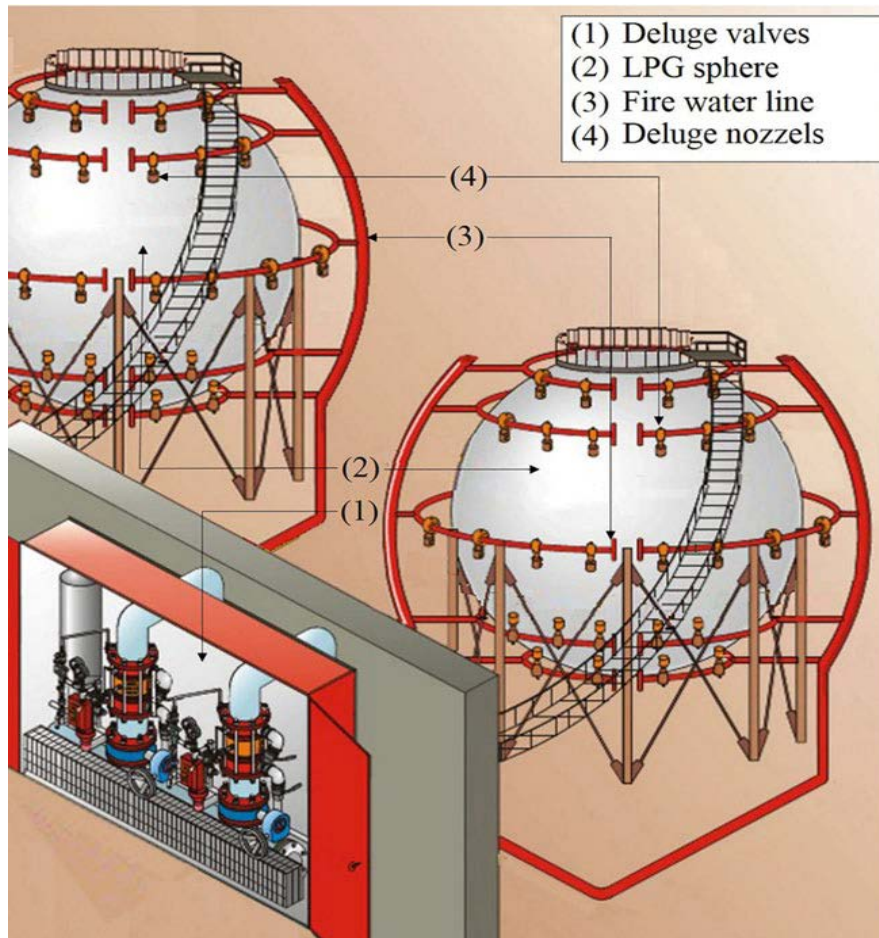

Figure 3.1 LPG sphere design

3.3.2. Phenomena observed

These have been classified into five categories :

Table 3.1 Phenomena used as a basis for classifying accidents

Phenomena
1.Liquid spreading on the ground
2.Gas phase leak without ignition
3.Jet (or pool) fire
4.Gas or vapour explosion
5.B L E V E

3.3.3. The severity of accidents

This was evaluated simply by dividing the accidents into two categories:

- Accidents not resulting in casualties.
- Accidents resulting in casualties.

Chapter III: Traditional methodology of risk assessment in FMECA

Some 55% of the accidents did not result in casualties. In 15 of the listed cases there were casualties (injury or death) and the phenomena responsible are shown in the figure below.

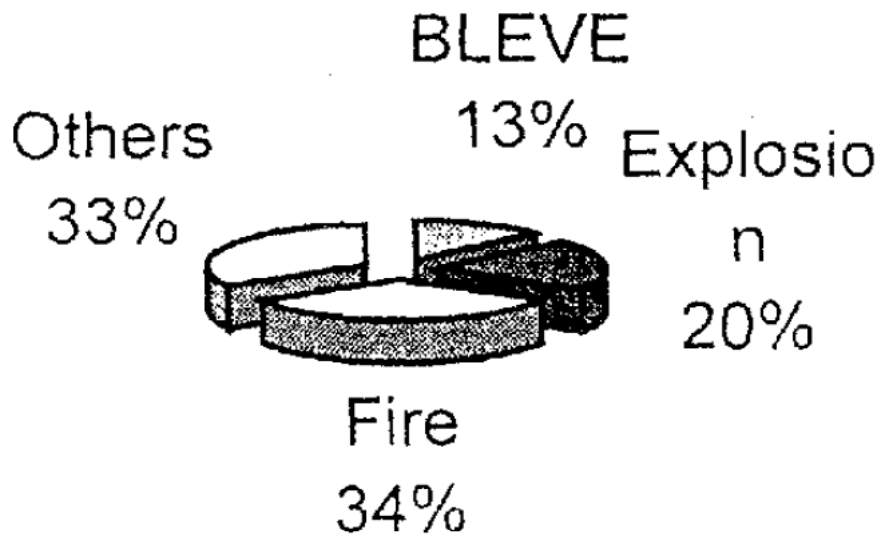

Figure 3.2 Causes of injury or death[85]

3.3.3.1. The causes of accidents

Any accident, even if it affects a whole area, is "usually caused by a particular action or system. In the present case therefore, we looked into the nature of the causes and separated the main groups of causes-circumstances occurring. Their distribution is shown in the figure 3.3[85].

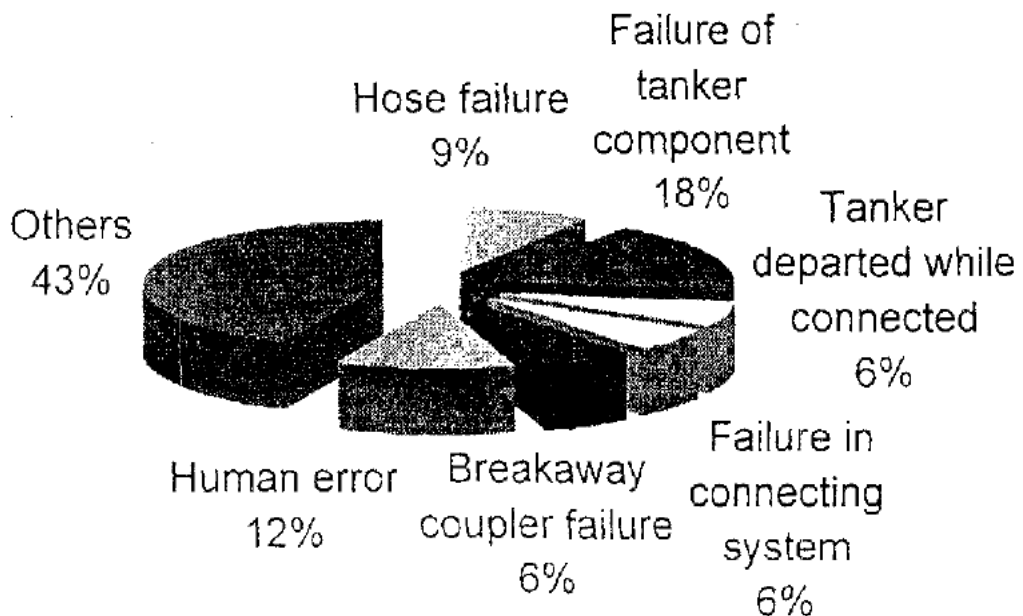

Figure 3.3 Breakdown by type of cause-circumstance[85]

Chapter III: Traditional methodology of risk assessment in FMECA

3.3.3.2. Important safety elements

Numerous risk control measures have been put in place both in terms of the prevention of major accidents and in terms of protection / intervention against its consequences. We can cite in particular:

- Safety valves that protect the whole unit,
- During unit operation: regular inspection to ensure that the equipment does not suffer from corrosion or mechanical fatigue,
- The presence of pressure and temperature control systems on the whole unit equipped with alarms and safety devices that automatically shut down and isolate certain systems in the event of excessive deviation of these parameters,
- The fire resources of the LPG adapted to the risks and to the equipment to be protected: deluge systems, water curtains, and means of protection specific to hydrocarbon or LPG storage tanks.

3.4. Traditional FMECA method for criticality evaluation (case study I)

As we have mentioned previously In FMECA, the RPN is obtained by multiplication of three inputs, probability of occurrence (F), Severity, and non-Detection. The probability of occurrence is represented as the likelihood that a specific cause will appear. Severity is an evaluation of the effect of potential failure mode. Detection is an evaluation of the ability of current design control to detect a potential cause. In global, these three parameters are evaluated by experts based on commonly agreed evaluation criteria

Table 3.5 illustrates the classic FMECA study for LPG storage system. The quotation scales of F, S, and ND are defined in Table (3.2, 3.3, and 3.4). The triggering threshold for corrective actions is defined as a minimum criticality equal to 45 which corresponds to 0.45 in the discourse universe [0.1][81].

Table 3.2 Severity rating

Severity index	Description
1	Negligible
2	Moderate
3	Critical
4	Catastrophic

Table 3.3 Frequency rating

Frequency index	Description
1	Improbable
2	Rare
3	Occasional
4	Frequent

Chapter III: Traditional methodology of risk assessment in FMECA

Table 3.4 Non-detection rating

Non-detection index	Description
1	Almost certain detection
2	Moderate chance of detection
3	Low chance of detection
4	Cannot detect

Table 3.5 FMECA of the LPG sphere system

Item	Function	Failure mode	Causes of failure	Effect of failure	criticality			
					F	S	ND	RPN
Sphere 500 m ³	LPG Storage	Rupture of the sphere	loss of containment	-Leaking -BLEVE - Safety valve opening	3	3	3	27
the sphere's supports	Support the sphere	Loss of balance	- Corrosion - earthquake - Errors of Constructio n	-Deformation of the Sphere - Fissure of the sphere can lead to a BLEVE.	2	3	3	18
Safety relief valve	Gas evacuation to the atmosphere	blocked closed - blocked open - Sudden Closure .	- clogging of valve elements. - Loss of elasticity of the valve spring. - human error	- sphere overpressure. - sphere depression. - major leak	4	2	1	8
Level switch low low LSLL	-Level indicator -Closed the SDV valve on the LPG outlet	- Wrong indicati on -Does	-Loss of power supply - Wrong setting	Unknown level in the sphere -Collapsage of the sphere	3	2	1	6

Chapter III: Traditional methodology of risk assessment in FMECA

	- Stopped the pumps	not work		-Cavitation of pumps				
Level switch high high LSHH	Level indicator - Closed the SDV valve on the LPG arrival	- Wrong indication -Does not work	-Loss of power supply - Wrong setting	Unknown level in the sphere - Overpressure of the sphere	1	3	1	3
Piping (pipeline)	LPG circulation stored	- Rupture	-Internal or external corrosion -Mechanical shocks -Human error	-Leak, environmental pollution -Significant LPG leak in gaseous and liquid state (critical fire zone)	1	4	1	4
Deluge valves	Deluge System Command	-water leak - untimely opening faulty guard valve	-presence of grain of sand -mechanical failure	Deluge system does not work	1	2	3	6

In our case, we will study the failure mode n°1 (most critical mode). For FMECA criticality evaluation is normalized RPN (risk priority number), where RPN is given as $RPN/64$. Consider, failure mode n°1 with the frequency of a failure mode is occasional, severity is critical, and non-detection is Low, RPN will be:

$$RPN = F \times S \times ND / 64 \rightarrow RPN = 3 \times 3 \times 3 / 64 = 0.42$$

Part II (Case study II): an industrial Gas Turbine System

3.5. Gas turbine

The system chosen case study 2 is a gas turbine system, the diffusion of these systems has been widely observed in Algeria. It is a combustion engine that can convert mechanical energy from natural gas. This energy is then used to power a generator which generates electricity. This system is shown in figure 3.4

A gas turbine is a complex system with lots of rotary and stationary parts is used for generating electric power. The gas turbine is quite new in the history of energy

conversion. The first practical gas turbine used to generate electricity ran at Neuchafel, Switzerland in 1939 and was developed by the Brown Boveri Company.

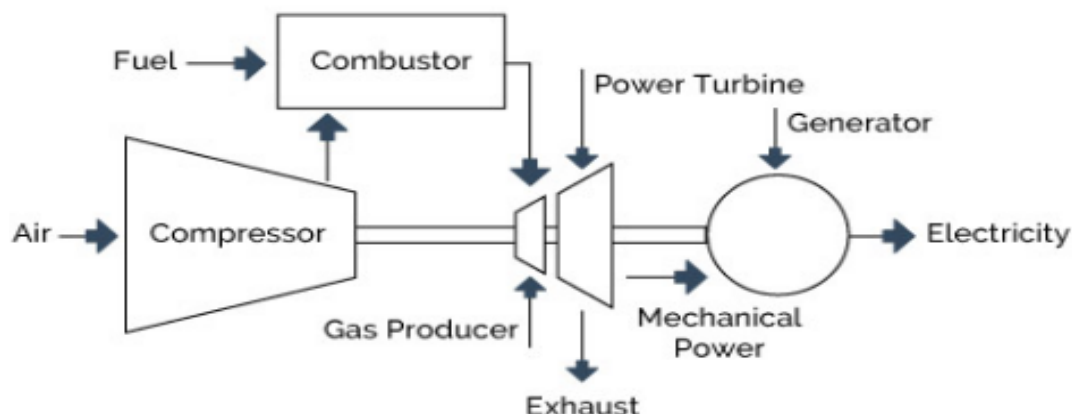

Figure 3.4 Gas turbine design[86]

3.5.1. Gas Turbine Categories

3.5.1.1. Aeronautical Gas Turbine

In comparison with internal combustion engines, gas turbines are lighter and smaller and have a very high power to weight ratio. Though they are mechanically simpler than reciprocating engines, and their characteristics of high speed and temperature operation require high precision components and durable materials making them more expensive to manufacture.

3.5.1.2. Electrical Power Generation

In electricity generating applications the gas turbine is used to drive a synchronous generator which provides the electrical power output but as far as the turbine normally operates at very high rotational speeds it must be connected to the generator through a high ratio reduction gearbox.

3.5.2. Gas Turbine Configurations

Gas turbine power generators are used in two basic configurations:

- Simple Cycle: This cycle is consisting of the gas turbine driving an electrical power generator (as shown in Figure 3.5).
- Combined Cycle: Obtaining the maximum efficiency is the objective of combined cycle designers, also the hot exhaust gases of the gas turbine are used to raise steam to power a steam turbine with both turbines being connected to electricity generators (as shown in Figure 3.6).

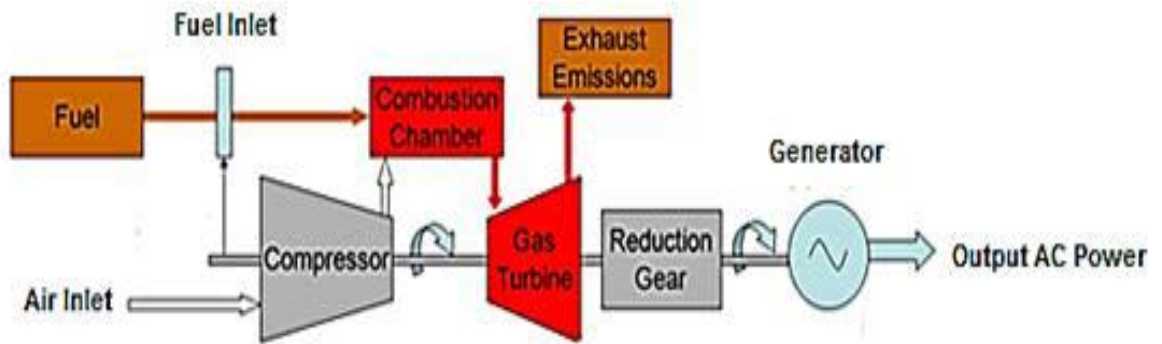

Figure 3.5 The schematic of simple cycle gas turbine power generator

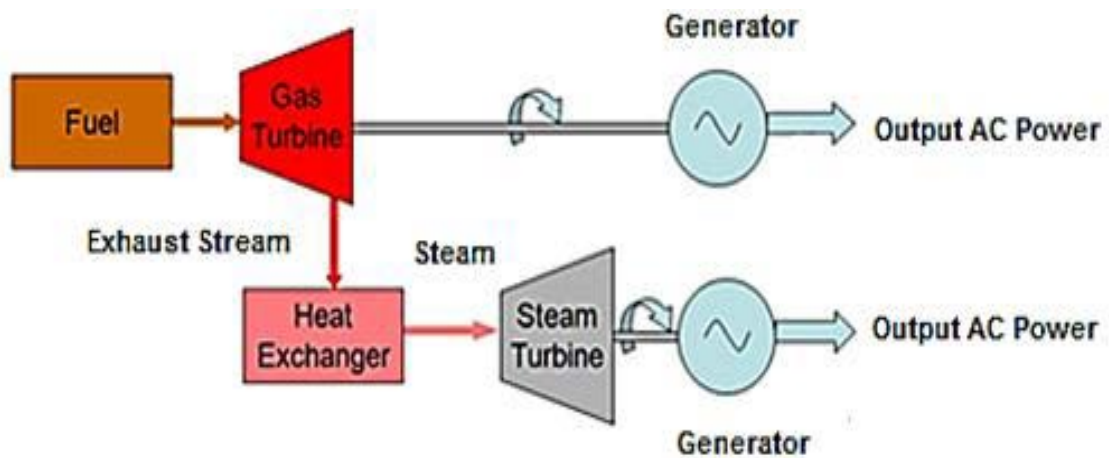

Figure 3.6 The schematic of combined cycle power generator

3.5.3. Working Principle of a Gas Turbine

In a gas turbine unit, the inlet ambient air is compressed by passing through several stages of stationary and rotary blades and can then be used both in the combustion chamber and for cooling purposes. The compressed air that enters the combustion chamber is mixed with fuel and is ignited to provide a high pressure, high velocity, and high temperature gas flow that is able to drive the turbine shaft at high rotary speeds. However, due to the precise design conditions of gas turbine units and the high rotary speeds at which they operate, the malfunction of one component can lead to severe damage to the entire unit. In between, the rotary and stationary parts of the turbine section, such as blades and disks, are more prone to failure because they work in a corrosive environment under a high temperature gas flow with a high pressure gradient.

The reason why gas turbine is very practical and being used by many companies is because it has lots of advantages. Some of the principle advantages of the gas turbine are

Chapter III: Traditional methodology of risk assessment in FMECA

because it can produce large amounts of useful power for a relatively small size and weight. Since motion of all its major components involve pure rotation (i.e. no reciprocating motion as in a piston engine), its mechanical life is long and the corresponding maintenance cost is relatively low. Even though the gas turbine must be started by some external means (a small external motor or other source, such as another gas turbine), it can be brought up to full-load (peak output) conditions in minutes as contrasted to a steam turbine plant whose start up time is measured in hours. A wide variety of fuels can be utilized. Natural gas is commonly used in land-based gas turbines while light distillate (kerosene-like) oils power aircraft gas turbines. Diesel oil or specially treated residual oils can also be used, as well as combustible gases derived from blast furnaces. The usual working fluid is atmospheric air. As a basic power supply, the gas turbine requires no coolant (e.g. water).

Figure 3.7 shows is the functional tree of a gas turbine where it listed down the main systems and components of a gas turbine system. The equipment is divided into five main subsystems: trunnion support, compressor, combustors, and power turbine and start/stop subsystem. Those main subsystems are divided into more detailed components, each one performing a specific function[87].

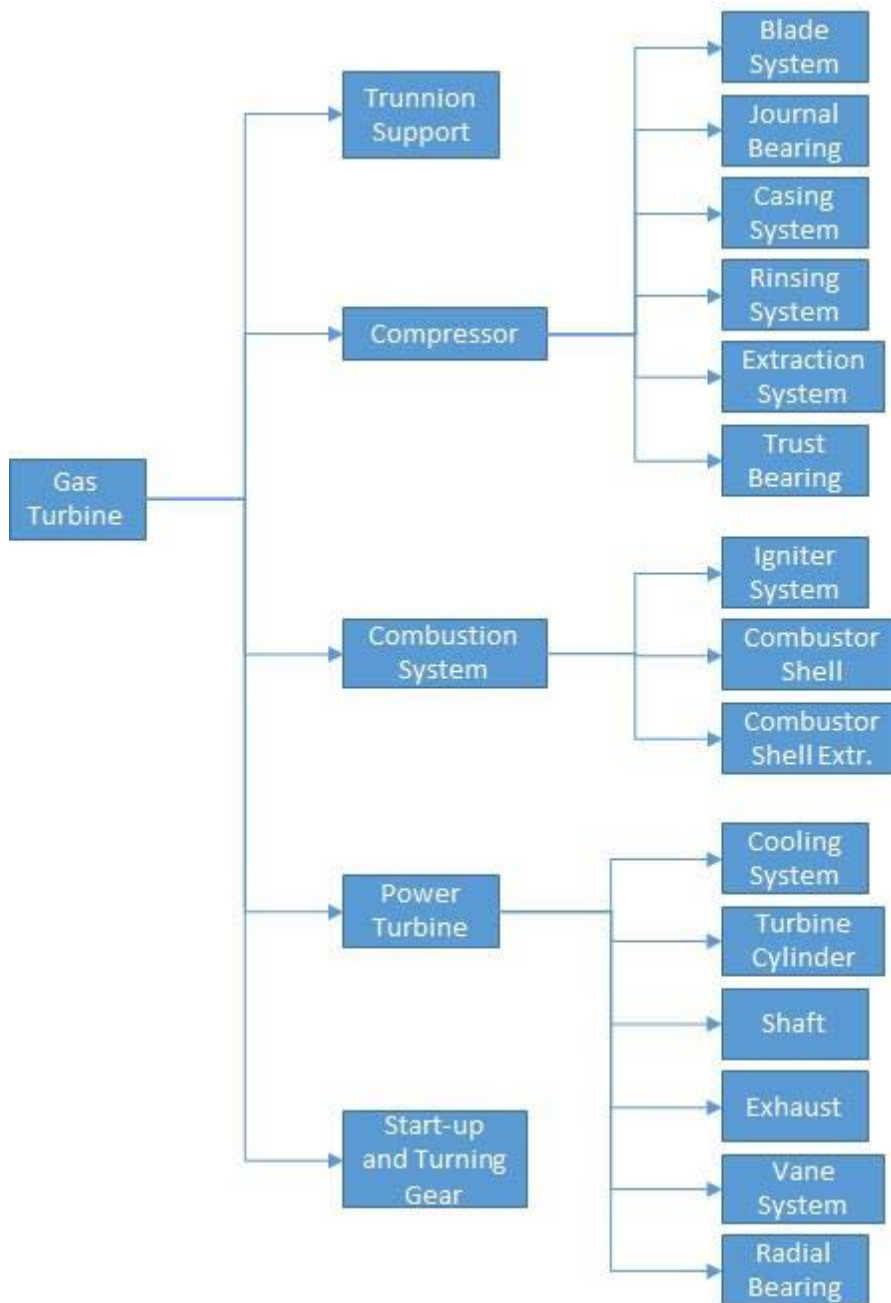

Figure 3.7 Functional Tree of Gas Turbine.

3.5.4. Common Failures in Gas Turbine System

Common failures in the gas turbine system were studied by different authors, with the aim of preventing future failures by improving the mechanical design, designing new materials, or proposing guidelines for better maintenance and utilization of gas turbine units. The failure mechanism of the gas turbine due to damage in turbine disks or blades is studied in by using visual inspection, macro and micro fractography, and numerical mechanical analyses. In these studies, the fatigue fracture, existence of region with high stress levels, creep, foreign object

Chapter III: Traditional methodology of risk assessment in FMECA

damage, and material degradation due to surface erosion were identified as the main failure mechanisms.

The common failure modes of a general gas turbine can be classified as follows, shown in Table 3.6

Table 3.6 Failure modes of gas turbine system

Component	Element	Failure modes
Compressor	Rotor blades	Vibration, Over-speed, erosion, Over temperature
	Rotor (disk)	Fatigue, creep ,stall
Turbine	Rotor blades	Creep, fatigue, corrosion, erosion
	Rotor (disk)	Creep, rupture, fatigue
	Stators	Creep, fatigue, corrosion, erosion, buckling
Combustion chamber	Linear	Hot Spot on Flame Tube , Flame Out, Flame Leakage
	Casing	Fatigue

3.5.4.1. Vibration

One of the two engine rotors is called compressor rotor which is located at the front of the engine and its duty is to compress the incoming air. The main reason for the mentioned failure is failing the bearings at the beginning and end of the rotor which damp the incoming vibrations. But among other reasons that are less likely to occur, we can mention loose engine installation mounts that cause the engine to place at an angle to the horizon and despite the low probability of occurrence, severe vibration is entered to the system. Another possibility of this malfunction could also be the electric fault of vibration indicator in which case rotors are serviceable

3.5.4.2. Over temperature

Through the section of the intake air, the compressor increases the pressure and the temperature and guides it to the combustion chamber with a minimum speed. In case the intake air has a higher temperature than the limit (the operating environment is hotter than specified)

Chapter III: Traditional methodology of risk assessment in FMECA

then with the passage of hot air from compressor stages, compressor outlet air isn't suitable for combustion and compressor over-temperature failure occurs.

3.5.4.3. Over-speed

Among the indicators that are placed against the user in control panel and are very important in monitoring when the jet engine is operating is speed indicator (RPM indicator) and according to the extent that is defined for these indicators, if engine speed exceeds a certain threshold, safety of the moving parts primarily and also the components that are in their vicinity will be compromised.

3.5.4.4. Stall

One of the most important factors that highly affect the performance of the gas turbine is air or gas streamline flow inside the engine, because wherever the flow is distorted from its direct linear form and takes the shape of a vortex, the engine power output is sharply reduced. Stall failure is the result of vortex flows' emergence which that are usually created in effect of ice formation or a barrier in the inlet of the engine or damage to compressor blades in collision with a foreign object which causes disruption of air or gas flow.

3.5.4.5. Flame Out

The only cause of the rotation of jet engine turbine blades is gas flow which is generated inside the combustion chamber and if any problems arise in this flow, turbine rotor rotation and consequently power generation of generator rotation will be disrupted. Stoppage of the gas flow into the combustion chamber failure is called flame out and one of the main causes of this failure is a component through which fuel is sprayed into the combustion chamber for burning (fuel nozzle). Partial or total clogage of fuel nozzles is highly effective in produced gas volume and because of nozzle congestion with not burned carbon masses, fuel can't be withdrawn and flame.

3.5.4.6. Flame Leakage

The reason for this failure is as RPM fluctuation, only in this failure we'll face gas leakage and through combustion chamber casing, gases produced in combustion instead of being sent to the turbine find a way out and the received energy content by the turbine rotor reduces. Finding an escape is done by the gases from the mating line of the chamber or leaves a deep crack on the surface of emission chamber surface

3.5.4.7. Hot Spot on Flame Tube

The contact between combustion chamber inner components and the flame causes burns. If we consider the inner layer of the combustion chamber which is called the flame tube (as the

Chapter III: Traditional methodology of risk assessment in FMECA

main component of this part), the flame inside the layer causes thermal stress to all of its parts and the engine operation continues by increasing the amount of stress. Therefore finding areas that are discolored and are called —hot spots‖ is one of the main failures that occur in combustion chamber.

3.5.4.8. Erosion

Gas turbine engines operates in a hostile environment that is polluted with small particles are susceptible to erosion damage. Examination of a number of natural dust samples indicates that quartz is usually the most abundant erosive constituent, rarely falling below 70% by weight. Erosion is caused by the abrasive components that remove component materials from surface. This results in slight changes in shape and an increase in surface roughness, especially on the pressure side

3.5.4.9. Corrosion

Corrosion is an expanded oxidation caused by the existence of deposit. The deposit can contain salt contaminants, such as Na₂SO₄, NaCl, and V₂O₅. These contaminants combine to form molten deposits. But corrosion can also be enhanced by the influence of a solid or a gas. The phenomenon is obviously life limiting for turbine blade structural materials.

3.6. Traditional FMECA method for criticality evaluation (Gas turbine)

For the gas turbine system, the FMECA analysis was performed, as shown in Table 3.7, the associated RPN values have been calculated. The failure modes are assessed by providing a score to the severity, frequency, and non-detection factors. For this, a ten-level score system is employed, as shown in appendix B. An expert opinion is consulted while rating these criticality factors. The frequency, severity, and detection scores were employed. According to the FMCEA group recommendation, the RPN results allow for prioritizing actions to ensure that the gas turbine operates continuously and safely. Due to a lack of data and uncertainty, expert opinions were utilized to estimate the criticality factors.

Table 3.7 Conventional FMECA results

Failure mode Sequence N ^o	Item	Failure Mode	Failure Cause	F	S	D	Conventional RPN	Rank
1			Defective vibration indication	2	10	6	120	7

Chapter III: Traditional methodology of risk assessment in FMECA

2	Compressor (Rotor)	Vibration	Defective bearings	2	5	3	30	13
3		Over-temperature	Compressor rotor dirty	3	5	4	60	10
4	Compressor (Stator)	Stall	variable stator vanes Binding	3	6	4	72	9
5			Foreign object deteriorate	3	4	5	60	10
6	Combustion chamber (Fuel nozzle)	Flame-out	fuel nozzles obstruction or Partial clogage	4	6	2	48	12
7	Combustion chamber (Flame tube)	Hot spots on flame tube	Flame tube cooling failure and uneven flame distribution around it	4	7	2	56	11
8	Turbine (Rotor)	Vibration	Defective vibration indication	5	6	6	180	5
9			Defective bearings	5	8	3	120	7
10	Ancillary system. (Fuel system components)	Over-speed	High fuel flow	6	7	5	210	4
11		No start	water ,Air, ,or particles in fuel lines	2	9	5	90	8
		Stall	irregular fuel pressure	6	8	5	240	3

Chapter III: Traditional methodology of risk assessment in FMECA

12								
13	Ancillary system. (Electrical system components)	Faulty temperature indication	Open, short circuit in thermocouple circuit	6	9	3	162	6
14		Not reaching idle speed	Low electrical power	8	9	7	504	1
15		Defective speed indication	Internal tachometer failure	7	9	6	378	2

3.7. CONCLUSION

Access to total safety in different industrial activities requires implementation and development of HSE management. One of the crucial requirements for HSE management is the employment of new methods for the assessment and prioritization of work risks and so are risk management and promotion of reliability of processes being increasingly prevalent in the field of production and operation management.

The FMECA method is one of the approaches that used in this field. It enjoys high and suitable application and analyzability and these features popularize FMECA as the most common technique for risk analysis and safety reinforcement in different organizations.

In this chapter we have tried to apply the conventional FMECA method for two case study and show the effectiveness of this method to determine failure modes and their causes and effects for each component.

Furthermore, it proves in a variety of applications that the FMECA still has several shortcomings. In the next chapter we will try to resolve the shortcomings by improving the failure mode, effects, and criticality analysis method by suggestion new proposed approaches based on two main categories which are multi-criteria decision making (MCDM), and Artificial intelligence approaches (AI).

Chapter IV

Risk evaluation approaches in failure mode and effects analysis

4.1. Introduction

Catastrophic failures and dangerous consequences on products, processes, equipment, or services are often a point of the challenge for any organization. Over the last few years, organizations have developed research approaches to reduce or eliminate these sudden incidents and to anticipate their related risks at the earlier steps of activity if they still occur. For the first time, failure mode effect and criticality analysis (FMECA) was formally considered as a safety and criticality evaluation tool

As we have seen in previous chapters that the FMECA is defined as a method for analyzing a process or system to identify possible modes of failure (FMs), their causes, and effects on the system/process performance. The risk priority number (RPN) has been used to define each failure mode, which is calculated by multiplying three input factors, frequency (F), severity(S), and non-detection of failures (ND).

Furthermore, it proves in different applications that the FMECA still has several shortcomings[81, 86]:

- It's difficult to have precise numbers to evaluate the criticality value when failure modes are assessed in a complicated system.
- Due to the lack of a full theoretical understanding of its sources, RPN calculating function is frequently questioned.
- The FMECA with the calculation of a single criticality is insufficient for the relevance of decision-making.
- Various combinations of S, F and ND factors may give a similar RPN value. However, the criticality evaluation for the failure modes can be vastly dissimilar
- In the estimation of RPN, the relative importance of criticality parameters is not considered.
- Another drawback of the classical RPN is the specific evaluation of criticality parameters regarding each failure mode. However, because of limited data, time pressure, or experts' information processing abilities are limited, risk parameters

Chapter IV: Risk evaluation approaches in failure mode and effects analysis

cannot be specified precisely, and the criticality evaluation information may be uncertain or imprecise

According to the shortcomings cited above we will try in this chapter to improve the use of failure mode, effects and criticality analysis by using new proposed modellings especially based on multi-criteria decision making (MCDM), and Artificial intelligence approaches (AI).

Part I

Fuzzy multi-criteria approach for criticality assessment and optimization of decision making

4.2. Application of the proposed methodology to the LPG storage system

in this part , we propose a novel hybridization methodology, which combined with a fuzzy multi-criticality approach and analytic hierarchy process (AHP), the latter has not taken many critiques and it is known as one of the best and most widely utilized for decision -making, it classifies the alternative from the best choice to the worst. The contributions and innovations of this model are summarized

- To avoid the complexity and uncertainty of in-formation, for each failure mode the authors replaced the one global criticality calculated from the classical method with a fuzzy inference system that offers five different criticalities that efficiently and separately calculate the impact of a failure on the environment, personnel, production, equipment, and management.
- Due to the doubts of the fuzzy system (if-then rules limits) that cannot give a precise numerical evaluation of criticality, the calculation of the overall criticality is based on a combination between AHP method to calculate the different priorities weights and the five partial criticalities calculated by the fuzzy inference system.
- The proposed approach can not only deal with identification, evaluation, and ranking failure modes as it was in previous researches, and not only deal with the subjectivity and vagueness but also to improve the aptitude of decision-making by trying to implement an action plan “preventive –corrective actions” in order to take priority of these actions and comparing their classifications towards each criticality importance (environment, personnel, production, equipment, and management) to

Chapter IV: Risk evaluation approaches in failure mode and effects analysis

reduce the frequency of occurrence and the severity of undesirable scenarios and safety improvement effectively.

As we have cited that the idea presented in this work is based on the combination of the fuzzy inference system and the analytic hierarchy process (AHP) to calculate the overall criticality and improve decision making. Figure 4.1 shows the process of the proposed approach. It based on three fundamental steps:

- 1st step: the quantification of the various performance indicators: frequency (F), severity (S) (S1, S2... S5), and non-detection (ND) to use them as input variables.
 - Frequency of occurrence: For the quantification of the frequency of occurrence the authors used the fault tree method, it is a top-down, deductive failure analysis, this analysis method is primarily used in safety and reliability engineering to understand how systems can fail, to find the best ways to reduce risk.
 - Severity level of failures: The severity quotation scales are based on the decree of September 29, 2005 (regarding the frequency assessment, the intensity of effects, and the severity under authorization-French regulations) and on methodologies specific to the SONATRACH group (appendix C)
 - Probability of non-detection: The probability of non-detection expresses the technological or organizational possibilities for detecting failures before the effects occur. Practically, this can be achieved with alarm mechanisms or the detection of warning signs. Our indicator is based on statistics and analysis of failure histories.
- 2nd step: a fuzzy system inference is called to develop appropriate membership functions. The design and development of a fuzzy inference system require the adoption of a structured demarche subdivided into three stages mentioned previously to ensure a judicious choice of the various parameters to determine the different criticalities. The first is “fuzzification”, it involves the choice of the study interval for each input (F, S (1,2...5) , ND) and the different outputs C(1, 2,...5) of the system, the number and the type of input/output membership functions must be defined and the discourse universe must be normalized. The fuzzy inputs resulting from the "fuzzification" are then evaluated by a fuzzy inference engine by using the different fuzzy rules to determine the five different criticalities which

Chapter IV: Risk evaluation approaches in failure mode and effects analysis

measure the impact of a failure on the environment, personnel, the production, the equipment, and management. The last step is to perform defuzzification using an appropriate method.

- 3rd step: AHP method is applied to determine the overall criticality by calculating the priorities weights for each partial criticality and by using the values criticalities calculated previously, then generating an action plan to improve the decision-making by prioritizing “preventive –corrective actions” according to the importance of the different criticality and seeing what is the efficient action for each criticality to re-duce the frequency and the severity of undesirable scenarios.

Figure 4.1 Flow chart of the proposed approach

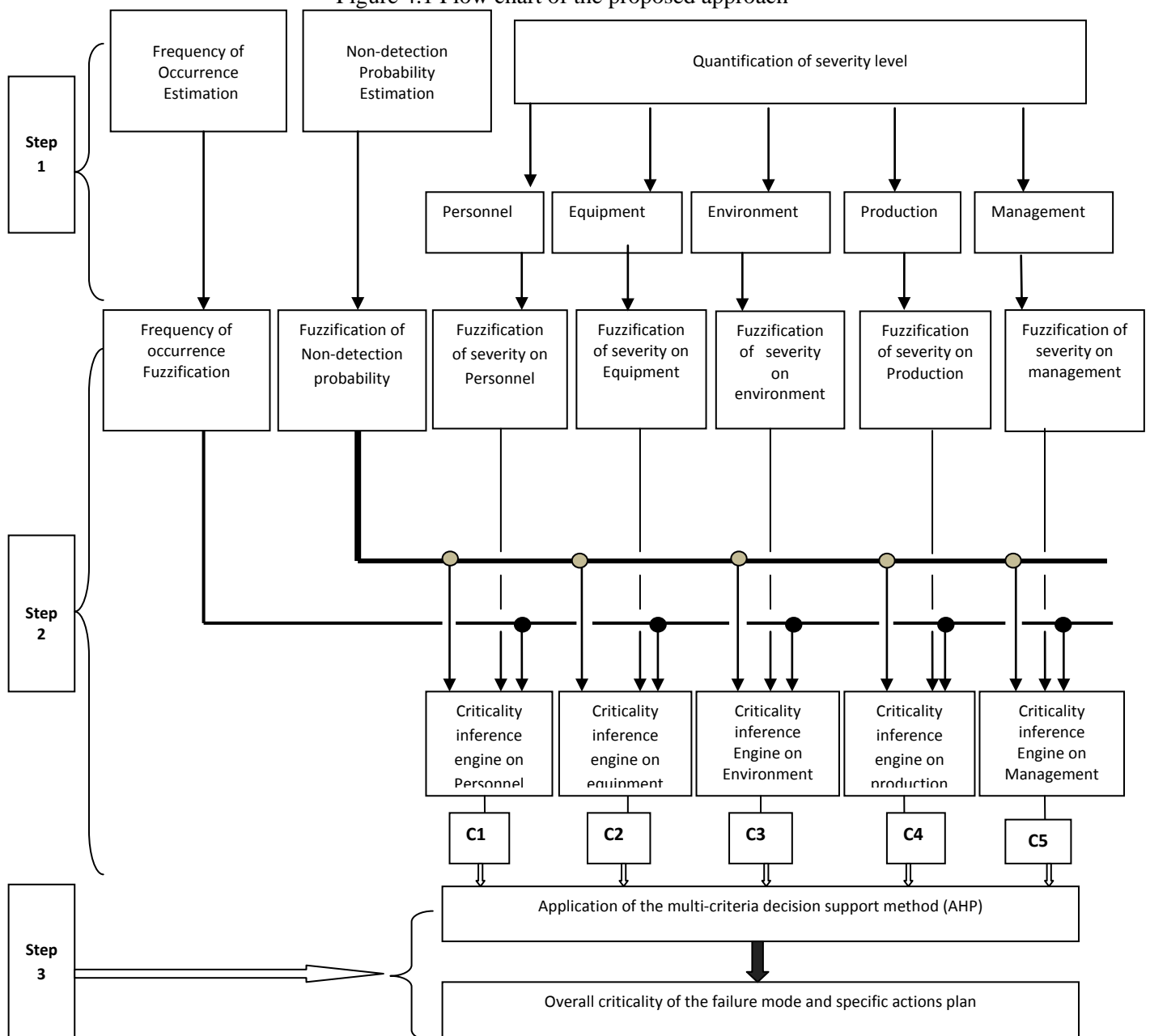

4.2.1. Quantification of the various input parameters (Step 1)

The first step to treat the failure mode n°1 is the exploitation and quantification of the various performance indicators: frequency, non-detection, and severity. To obtain the frequency of occurrence for the undesirable event “loss of confinement” which presents the main cause of failure mode 1, the authors used the fault tree method (FTA) shown in figure 4.2[88]. The FTA combines numerical values of basic events to obtain a precise value of the system using logic gates. The numerical values of basic events are calculated by using exponential law for an operating time of 720 h; these events' values may also be constant as shown in table 4.1.

$$F(t) = 1 - e^{-\lambda t} \quad (4.1)$$

Where: ‘ λ ’ indicates the failure rate as presented in table 4.1.

Event (P001) = P002 \cup P003 \cup P004 \cup P005

$$=(N1+N2+N3+N4)+(N5+N6+N7+N8+N9+N10)+N11+(N12+N13+N14+N15)$$

Prob [loss of containment in the “LPG Storage” system] = 0.00155084 /hour, (Equal -2.8 on a logarithmic sc scale).

The quantification of the other input parameters, severity, and non-detection shown in Table 4.2:

Chapter IV: Risk evaluation approaches in failure mode and effects analysis

Figure 4.2 Fault tree analysis for “loss of containment in the LPG system”

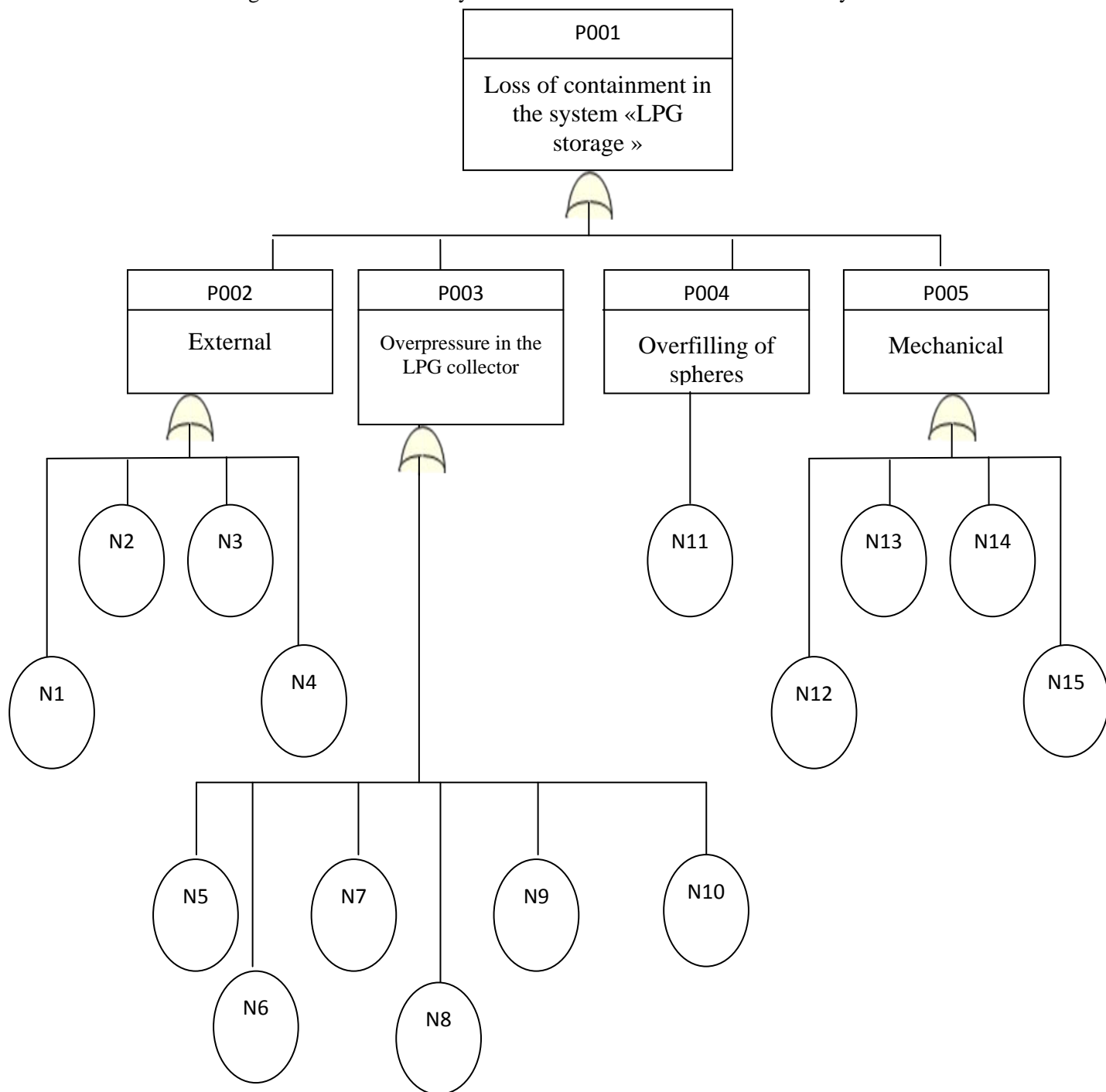

Chapter IV: Risk evaluation approaches in failure mode and effects analysis

Table 4.1 Data of LPG system components from OREDA

Node	Component /Events	Model	frequency of occurrence	Failure rate (λ)
N1	Lightning	Constant	1.0E-5	
N2	Works	Constant	1.0E-9	
N3	Earthquakes	Constant	1.0E-5	
N4	Roads (traffic)	Constant	5.0E-8	
N5	Sudden Closure of 33MOV00002in export phase	Exponential		5.0E-07
N6	Export pumps shutdown	Exponential		5.0E-11
N7	failure of 33PV01004 (closing) on the balancing line of the spheres	Exponential		2.0E-07
N8	Failure of 33PV01019 (closing) while the export phase	Exponential		2.0E-07
N9	Fire case	Constant	8.0E-05	
N10	Sudden Closure of 33ESDV00001	Exponential		3.4.0E-07
N11	Sudden Closure of 33MOV00001 in progress Filling	Exponential		5.0E-07
N12	Vibrations	Constant	4.0E-05	
N13	Aging	Constant	1.7.0E-07	
N14	Corrosion	Constant	1.5.0E-04	
N15	Erosion	Constant	8.0E-06	

Table 4.2 Data collection table for criticality calculation

Designations	Input data values
frequency of occurrence	0.00155084 /hour
Probability of non-detection (ND) (This corresponds to 1 failure not detected among 5 failures)	0.2
Severity on Personnel	1
Severity on Equipment	2
Severity on Environment	3
Severity on Production	4
Severity on Management	5

4.2.2. Fuzzy system Application to evaluate the five partial criticalities (Step 2)

By applying the three steps of the inference system mentioned previously, the next stage is calculating the different criticalities. The procedure for determining the fuzzy criticality consists of using the membership functions trapezoidal-shaped to describe inputs and output variables: as given in Figure 4.3.

Chapter IV: Risk evaluation approaches in failure mode and effects analysis

Frequency (F) is given by five fuzzy sets: rare, occasional regular, systematic, very-high defined on a space ranging from 10^{-6} to 1 represented in figure 4.3(a) as a logarithmic scale.

Severity (s) is represented by five fuzzy sets: very-low, low, normal, serious, very-Serious defined on a Severity space ranging from 1 to 5 (figure 4.3(b))

Non-detection (ND) is represented by five fuzzy sets, namely: very-low, low, medium, high, very-high represented on a space from 0 to 1 (figure 4.3 (c)).

The criticality (C), as the only output variable, is defined on ranging from 0 to 1 and is represented by five fuzzy sets: very-low, low, normal, high, very high (figure 4.3(d)).

In this case the different criticalities are determined based on 125 rules bases. Mamdani's inference system is used to derive the criticality values, figure 4.4 shows the obtained results (case of equipment criticality for Severity= 2).

a)

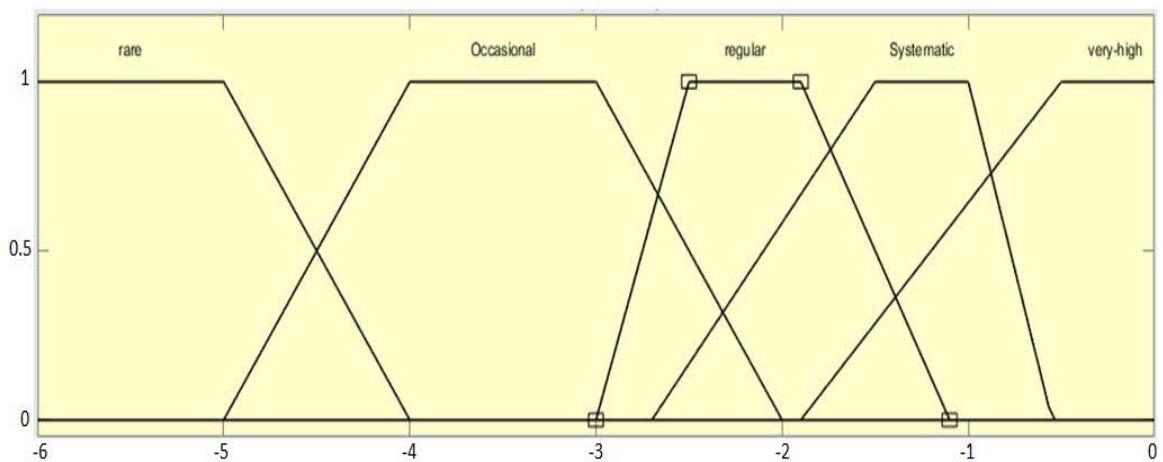

b)

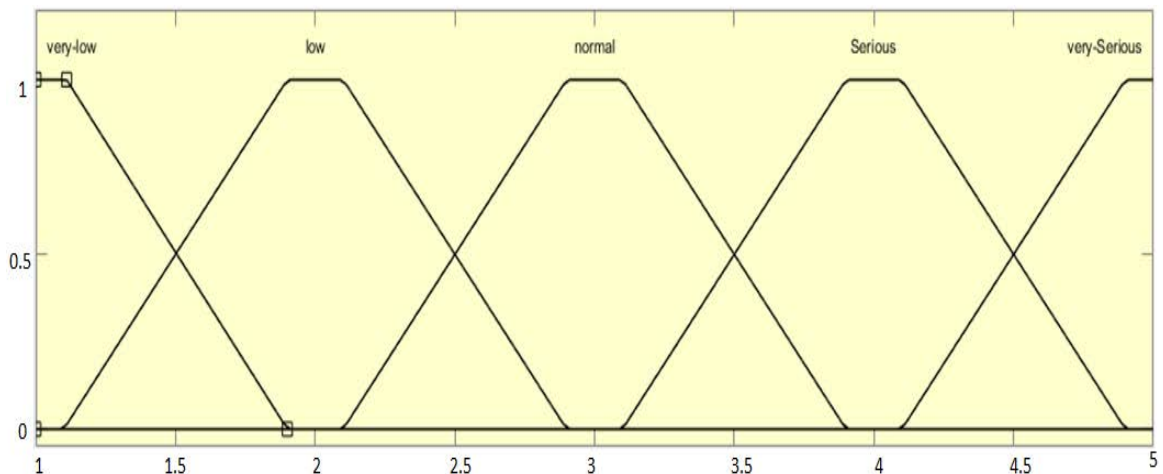

Chapter IV: Risk evaluation approaches in failure mode and effects analysis

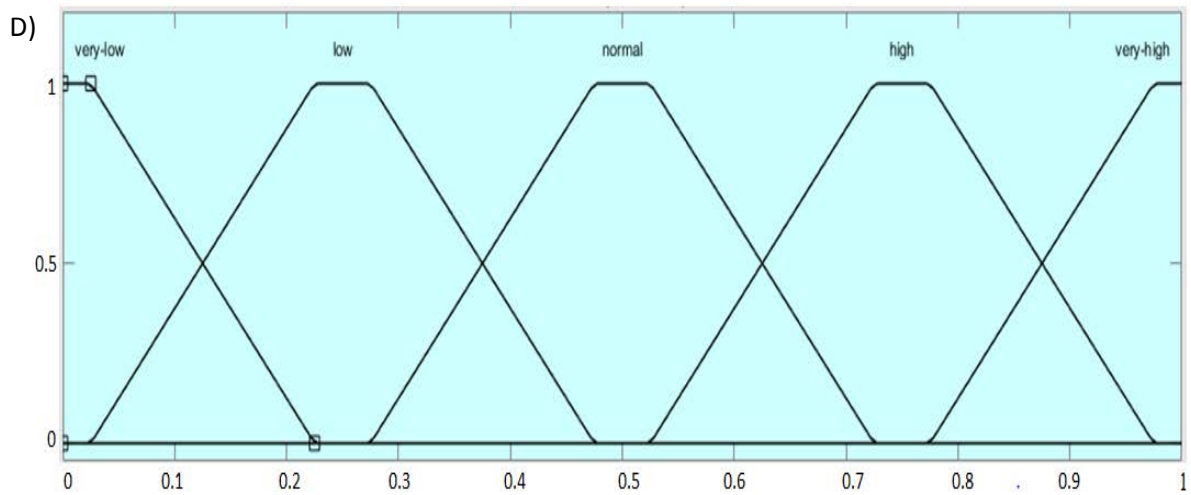
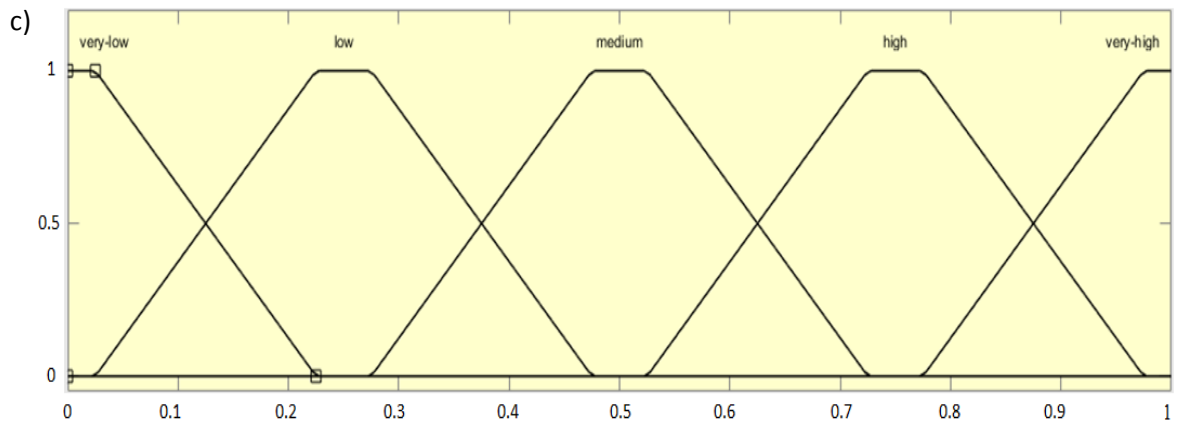

Figure 4.3 Membership functions generated for (a) frequency, (b) Severity and (c) non-detection (d) criticality

Chapter IV: Risk evaluation approaches in failure mode and effects analysis

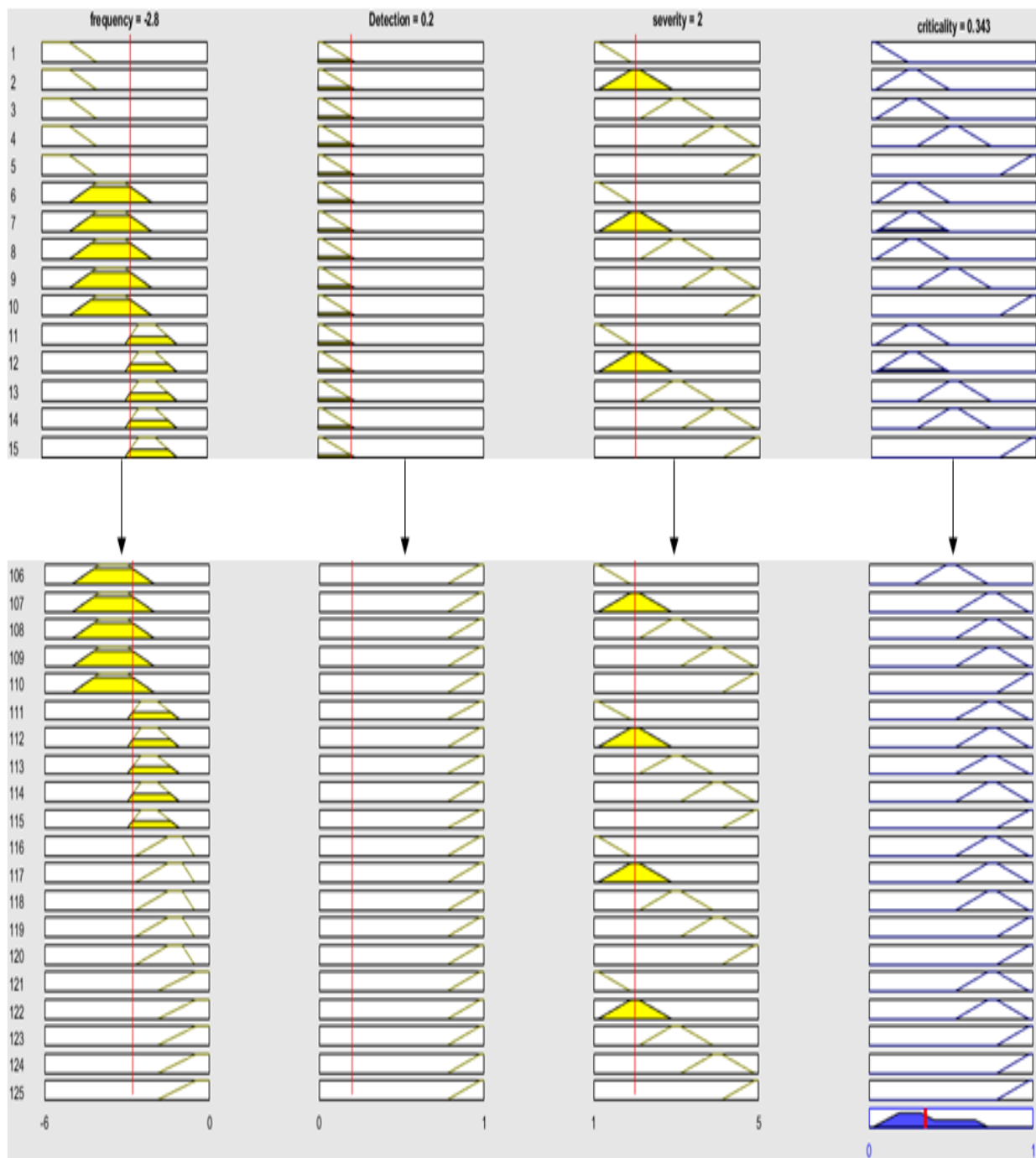

Figure 4.4 Fuzzy inference process: case of criticality on equipment.

Chapter IV: Risk evaluation approaches in failure mode and effects analysis

By applying the same methodology for all criticalities, the results given in table 4.3:

Table 4.3 Criticalities obtained from fuzzy inference engines

Criticality	values
Criticality on Personnel (C ₁)	0.250
Criticality on Equipment (C ₂)	0.343
Criticality on Environment (C ₃)	0.460
Criticality on Production (C ₄)	0.500
Criticality on Management (C ₅)	0.923

4.2.3. Application of the AHP method to evaluate the overall criticality and improving the decision-making (Step 3)

Based on the experts and responsible judgments, it has been determined that the criticalities C₁ and C₅ have effects more important than the other. The details of the judgments are presented in table 4.4.

Table 4.4 Comparison matrix for criteria

	C ₁	C ₂	C ₃	C ₄	C ₅
C ₁	1	3	5	3	1
C ₂	0.33	1	2	3	0.2
C ₃	0.2	0.5	1	2	0.33
C ₄	0.33	0.33	0.5	1	0.2
C ₅	1	5	3	5	1

By considering step 3 of the AHP method and applying the equation (3.2, 3.3 and 3.4), a new matrix has obtained representing the priorities of the Different judgments (table 4.5):

Table 4.5 The arithmetic priority of judgments

	C ₁	C ₂	C ₃	C ₄	C ₅	Sum	priorities
C ₁	0.35	0.3	0.43	0.21	0.36	1.65	0.335
C ₂	0.11	0.1	0.17	0.21	0.07	0.66	0.133
C ₃	0.08	0.07	0.09	0.14	0.12	0.5	0.091
C ₄	0.11	0.03	0.05	0.09	0.09	0.37	0.065
C ₅	0.35	0.5	0.26	0.35	0.36	1.82	0.376
Sum	1	1	1	1	1	5	1

Chapter IV: Risk evaluation approaches in failure mode and effects analysis

As an example the first weight w_{11} and priority p_1 are calculated as follows:

$$w_{11} = \frac{a_{11}}{\sum_{i=1}^5 a_{i1}} \rightarrow \frac{1}{1 + 0.33 + 0.2 + 0.33 + 1} = 0.350$$

$$p_1 = \frac{1}{5} \sum_{j=1}^5 w_{1j} \rightarrow \frac{0.35 + 0.3 + 0.43 + 0.21 + 0.36}{5} = 0.335$$

By using the different criticalities obtained in table 4.3 and the priorities of table 4.5, the overall criticality estimation for the proposed approach is calculating as follows:

$$GC_1 = P_1 \times C_1 + P_2 \times C_2 + P_3 \times C_3 + P_4 \times C_4 + P_5 \times C_5$$

$$GC_1 = 0.250 \times 0.335 + 0.343 \times 0.133 + 0.460 \times 0.091 + 0.500 \times 0.065 + 0.923 \times 0.376 = 0.550$$

Table 4.6 Criticality weights factors

Criteria	Values	Weighting factors W_i	Estimated overall criticality GC1	Classical FMECA Criticality GC2
C1	0.250	0.335	CG1=0.550	From table 3.5 CG2=27 compared to 64 is:0.42
C2	0.343	0.133		
C3	0.460	0.091		
C4	0.500	0.065		
C5	0.923	0.376		

The minimum criticality being defined as 0.45, corrective and preventive actions must be taken. Thus, we have to repeat the same criticality procedure for the next level which concerns the aggregation of the different types of actions. “Preventive –corrective actions” are presented as follows to improve the relevance of the decision-making:

- Technical Safety Barriers: safety instrumented System as (Emergency isolation and depressurization system, level switch high high, pressure switch high high), the different Safety devices...(TA₁).
- Methodological decisions: implementation of procedures and operating modes, Use of appropriate software for this procedure while linking it to computer databases, changes in process parameters as controls and planning frequencies, cadence...(TA₃)

Chapter IV: Risk evaluation approaches in failure mode and effects analysis

- Manual Action Systems of security: active protection against the fire, emergency shutdown button, manual closure of a safety valve... (TA4).
- Means deployment actions: Purchase of personal protective equipment, Recruitment of engineers specializing in industrial maintenance, a regular preventive maintenance program of equipment, training, and awareness-raising for operators, internal policies aimed at establishing and maintaining a rigorous culture of security and risk management (TA5).

According to brainstorming sessions, the type of actions are compared across to each criterion (table 4.7), then by considering the last step of the AHP method the priorities of the alternatives concerning all criteria are summarized in table 4.8

Table 4.7. Comparison matrix for alternatives versus criteria

personnel	TA ₁	TA ₂	TA ₃	TA ₄	TA ₅
TA ₁	1	0.2	0.33	0.16	0.12
TA ₂	5	1	2	1	1
TA ₃	3	0.5	1	0.33	0.25
TA ₄	6	1	3	1	0.5
TA ₅	8	1	4	2	1
Equipment	TA ₁	TA ₁	TA ₁	TA ₁	TA ₁
TA ₁	1	3	5	8	9
TA ₂	0.33	1	7	5	8
TA ₃	0.2	0.14	1	4	3
TA ₄	0.12	0.2	0.25	1	5
TA ₅	0.11	0.12	0.33	0.2	1
Environment	TA ₁	TA ₂	TA ₃	TA ₄	TA ₅
TA ₁	1	1	3	4	6
TA ₂	1	1	2	6	4
TA ₃	0.33	0.5	1	2	3
TA ₄	0.25	0.16	0.5	1	1
TA ₅	0.16	0.25	0.33	1	1
production	TA ₁	TA ₂	TA ₃	TA ₄	TA ₅
TA ₁	1	2	7	3	4
TA ₂	0.5	1	6	3	5
TA ₃	0.14	0.16	1	0.5	2
TA ₄	0.33	0.33	2	1	1
TA ₅	0.25	0.2	0.5	1	1
management	TA ₁	TA ₂	TA ₃	TA ₄	TA ₅
TA ₁	1	6	7	7	8
TA ₂	0.16	1	1	3	4

Chapter IV: Risk evaluation approaches in failure mode and effects analysis

TA ₃	0.14	1	1	2	2
TA ₄	0.14	0.33	0.5	1	2
TA ₅	0.12	0.25	0.5	0.5	1

Table 4.8 Global priority vector for different types of decisions

	C1 (0.335)	C2 (0.133)	C3 (0.091)	C4 (0.065)	C5 (0.376)	Priorities
TA ₁	0.042	0.485	0.367	0.421	0.617	0.371
TA ₂	0.250	0.314	0.339	0.320	0.149	0.233
TA ₃	0.103	0.105	0.156	0.075	0.114	0.111
TA ₄	0.243	0.065	0.072	0.110	0.070	0.130
TA ₅	0.363	0.030	0.066	0.074	0.049	0.155

To obtain a precise analysis of the results above the “expert choice software” has been used; it simplifies the implementation of the AHP method. Its general objective is to see graphically how the alternatives change according to the importance of the criteria. There are five types of analyzes: Performance Sensitivity, dynamic sensitivity, gradient sensitivity, head-to-head sensitivity, and two-dimensional sensitivity. In our case study, we analyze the results based on the performance and gradient sensitivity graphs

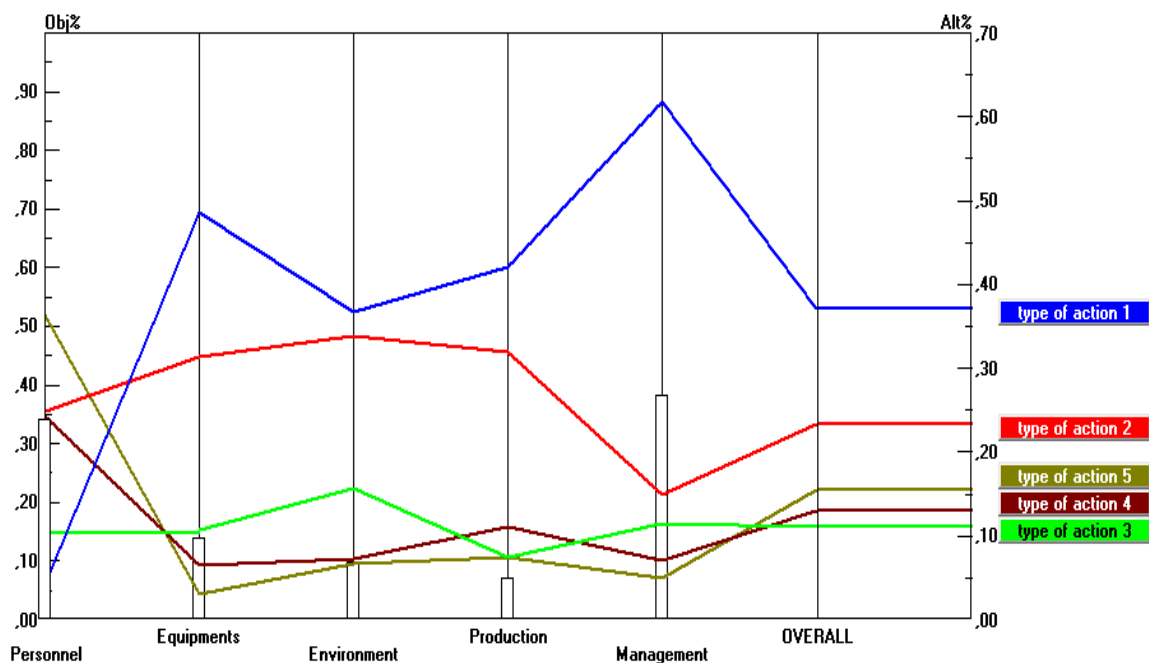

Figure 4.5 Performance sensitivity graph

Chapter IV: Risk evaluation approaches in failure mode and effects analysis

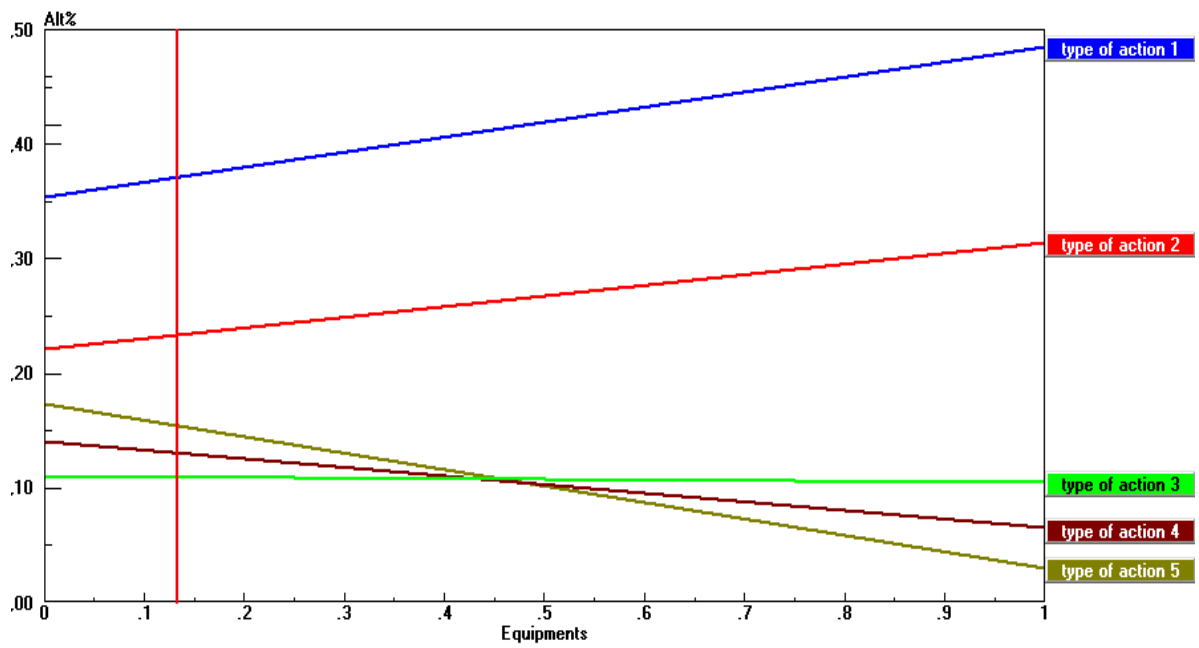

Figure 4.6 Gradient sensitivity graph for equipment

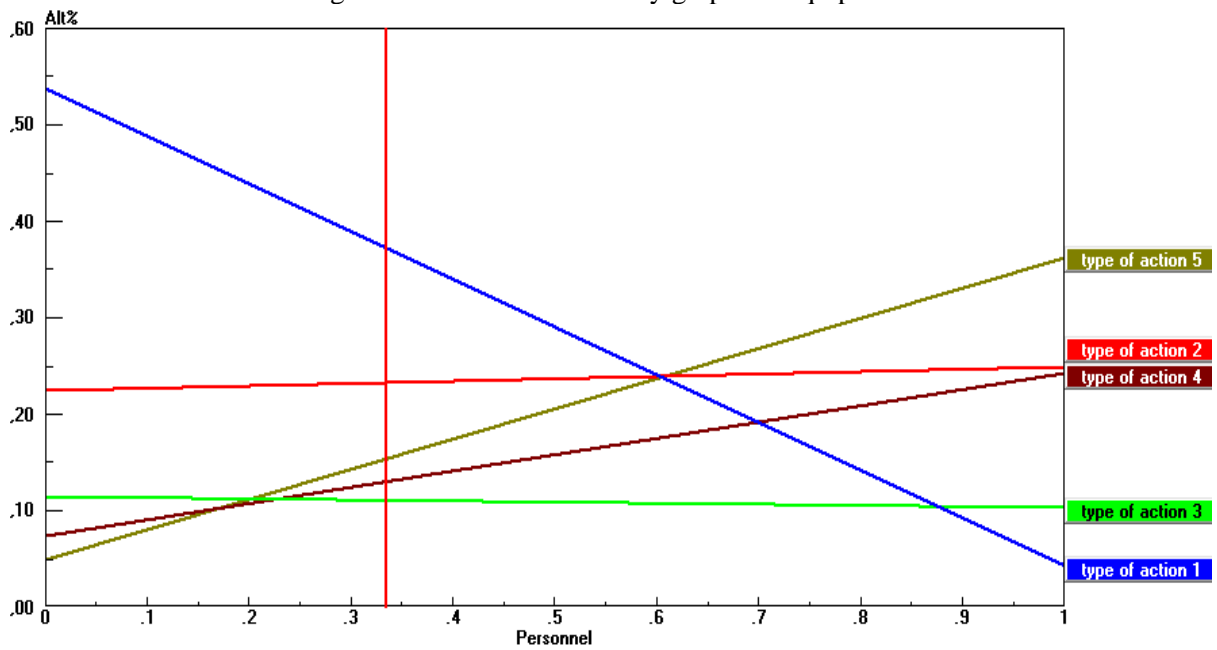

Figure 4.7 Gradient sensitivity graph for personnel

Chapter IV: Risk evaluation approaches in failure mode and effects analysis

Results analysis

The results obtained are interesting, as we noted earlier that the triggering threshold for corrective actions is defined as a minimum criticality equal to 45 which corresponds to 0.45 in the discourse universe [0.1]. In effect, it can be demonstrated from the real case that the FMECA method with (criticality = 0.42) did not lead to activate the corrective- preventive actions plan. On the other hand, a new fuzzy multi-criticality approach allows to a better and precise evaluation of the five criticalities and consequently the overall criticality (CG = 0.55) which was greater than 0.45 and that results in the triggering of action plans and types of decisions, This allowed to bring out the deficiencies in the estimation of the conventional FMECA method.

The inference engines, although simple in this case, made it possible to capitalize on the experience of the company. The different rules (R_i) constructed have allowed popularizing the influence of the FMECA parameters on each criticality. This gave more credibility to the criticality analysis since it is no longer about multiplying factors but rather building a conditional structure leading to significant criticalities.

For the company's executives, this technique allowed to improve communication mechanisms and experience exchanges. In fact, the case study provided an opportunity to guide judgments and adopting clear criteria allowing decision support. Thus, the AHP strategy assisted in bringing concepts closer together and showing the accuracy of the criteria, as well as evaluating the overall criticality which was critical in convincing management to take the identified actions.

Regarding the improvement of decision-making by prioritizing “preventive –corrective actions” and determining the most effective action for each criticality, a performance sensitivity graph (figure 4.5) clarifies the results provided in table 4.8 and shows that the technical safety barriers could be suggested decision-makers as a more appropriate alternative from all the alternatives with a priority of 0.371 followed by the type of action 2, type of action 5, type of actions 4, type of action 3, respectively. This does not imply that "action plan 1" is the best on all criteria it can be observed that the technical safety barriers are the best in only with the four criteria, equipment, environment, production, management, while it ranks fifth on the other criterion.

To clarify the results more, a gradient sensitivity graph is used as presented in figure 4.6 The case of equipment (C_2) shows that when the importance is not critical (Priority = 0), the type of decision 3 is still the worst choice from all of the other types of action with a priority

Chapter IV: Risk evaluation approaches in failure mode and effects analysis

of 0.111. However, if the equipment is extremely important (Priority = 1), technical safety barriers are far and away the efficient choice to control the criticality with a priority of 0.48. So, any smallest change in the weight of the criteria values that changes the current ranking of alternatives. As can be seen, the slope (direction and steepness) of the curve for each option indicates its dependence on the criteria. Not also, that alternative 3 is almost unaffected by the change in equipment criterion its curve is almost flat.

The case of personnel (C_1) shown in figure 4.7 depicts that if the priority of criticality on personnel is adjusted upwards from 0 to 0.6, the type of action 5 comes out on top. However, if the weight of criticality is larger than 0.6 the type of decision 5 becomes the most favorable alternative to ensure the safety of personnel with a priority from 0.225 to 0.363. This result makes a sense represented in the effectiveness of the type of action 5 based principally on training, awareness-raising and regular interview program versus the criticality on personnel protection, however; the actions 1,3 are the worst choice and actions 2,4 are almost equal and being somewhere in between.

Part II

Failure mode, effects, and criticality analysis improvement by using new criticality assessment and prioritization based approach

4.3. Application of the proposed methodology to the gas turbine system

This part aims to enable the analysts of reliability and safety system to assess the criticality and prioritize failure modes perfectly to prefer actions for controlling the risks of undesirable scenarios.

To resolve the challenge of uncertainty and ambiguous related to the parameters, frequency, non-detection, and severity considered in the traditional approach FMECA for risk evaluation, the authors utilized fuzzy logic where these parameters are shown as members of a fuzzy set which fuzzified by using appropriate membership functions. The ANFIS process is suggested as a dynamic, intelligently chosen model to ameliorate and validate the results obtained by the fuzzy inference system and effectively predict the criticality evaluation of failure modes. A new hybrid model is proposed that combines the grey relational approach (GRA) and fuzzy analytic hierarchy process to improve the exploitation of the FMECA conventional method.

Chapter IV: Risk evaluation approaches in failure mode and effects analysis

To resolve the shortcomings of FMECA method and improving its use, the novelty of this work are:

- To avoid the complexity and decrease the uncertainty of the judgments, for each failure mode, the authors replaced criticality calculated from the classical method with a fuzzy inference system. The latter can treat different types of ambiguities and uncertainty in assessing failure modes respectfully to the criticality factors. During modelling, by the imprecise linguistic expressions and the fuzzy inference system, human expertise is incorporated. The ability to grasp inference systems empowers users and professionals to customize them effectively
- An adaptable neural network-based fuzzy inference system is created to compare and validate the results obtained by fuzzy inference system assessment; it's simple to combine both numeric and linguistic knowledge in order to solve the fuzzy problem produced. By training the neural network to apply the fuzzy rule base of human experts, the ANFIS system is anticipated to identify previously undetected decisions.
- Different approaches can give different prioritizations, and every approach has its disadvantages and advantages. Consequently, the integration of two multi-criteria decision methods and incorporating their results enables to instill confidence in decision-makers regarding to the criticality prioritizations results of failure modes, especially when dealing with complicated systems. Wherefore, in this research, a novel hybrid approach that combines the grey relational approach (GRA) and fuzzy analytic hierarchy process may solve this problem. This approach gives an alternate prioritizing for the failure modes and allows overcoming the shortcomings concerning the lack of established inference rules which necessitate a good deal of expertise, and shows the weightage or importance for the severity, non-detection, and the frequency which are considered to have equal importance in the traditional method.

4.3.1. Failure mode analysis by fuzzy methodology

The RPN values are calculated using the fuzzy inference technique to represent the fuzzy theory sets. As given previously, the process comprises one output and three input variables. The inference engine determines the RPN by incorporating three input factors. A Gaussian membership function is used for input variables to generate real numbers to fuzzy sets, given by equation 17. Trapezoidal and triangular membership functions are used for the output variable (equation 3.18, 3.19, and 3.20)

Chapter IV: Risk evaluation approaches in failure mode and effects analysis

Five and six levels are utilized for input and output variables, respectively, as given in figures 4.8, 4.9. Expert opinion is employed as language terms for the frequency, detection, and severity values of failures. As shown in the appendix D, twenty-seven rules are used to determine criticality priority in the inference system.

The Mamdani min/max approach was used for inference, while the gravity center technique was utilized for defuzzification (see equation 3.24). The gravity center method is described as a centroid defuzzification method for determining the fuzzy set's center of gravity point on the fuzzy interval. The traditional and fuzzy risk priority number results are presented in Table 4.9.

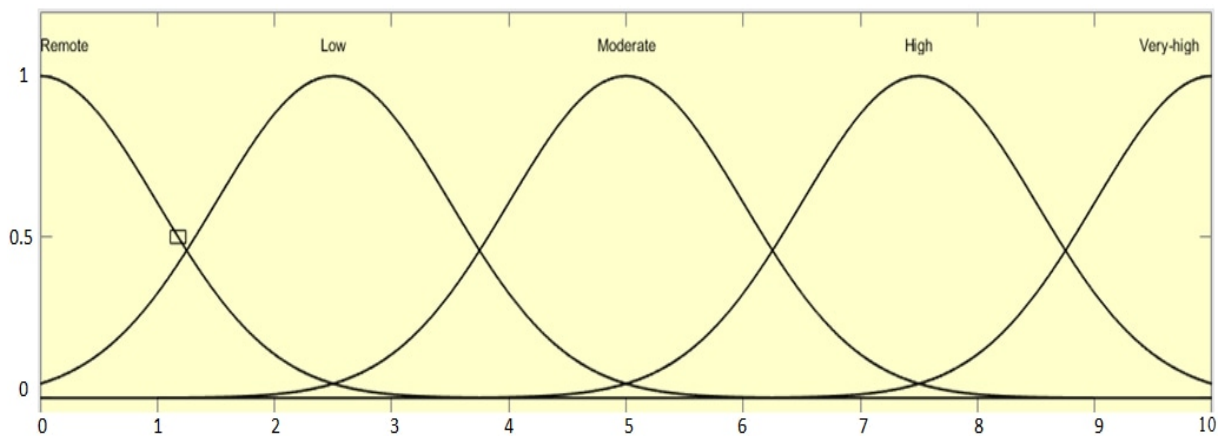

Figure 4.8 Membership functions generated for, probability, Severity and non-detection

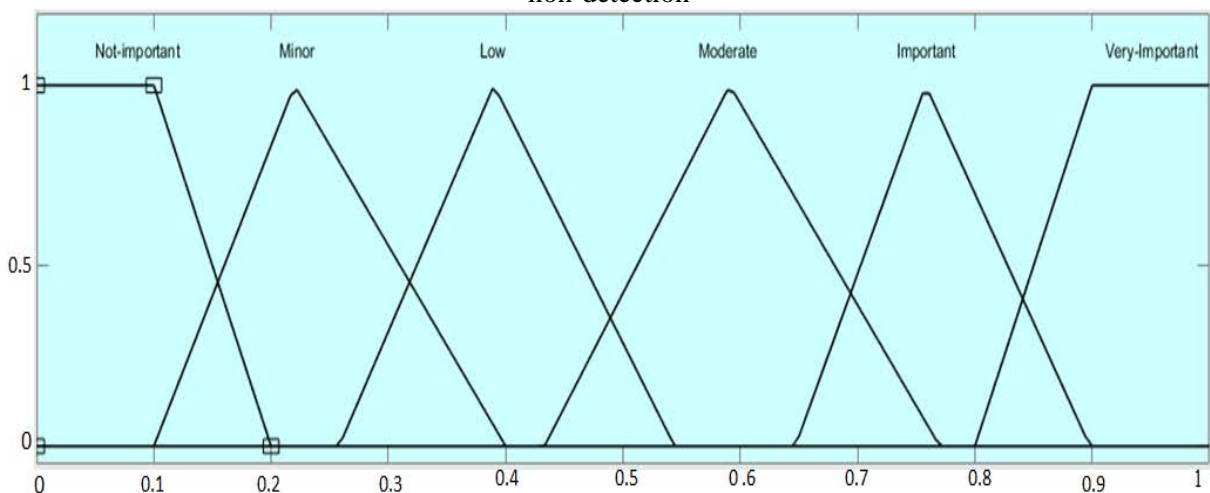

Figure 4.9 Membership functions of output variable "criticality"

Chapter IV: Risk evaluation approaches in failure mode and effects analysis

Table 4.9 Conventional FMECA and fuzzy RPN results

Failure mode Sequence N°	Item	Failure Mode	Failure Cause	F	S	D	Conventional RPN	Rank	Fuzzy RPN output	rank
1	Compressor (Rotor)	Vibration	Defective vibration indication	2	10	6	120	7	0.455	7
2			Defective bearings	2	5	3	30	13	0.20	15
3		Over-temperature	Compressor rotor dirty	3	5	4	60	10	0.249	13
4	Compressor (Stator)	Stall	variable stator vanes Binding	3	6	4	72	9	0.272	12
5			Foreign object deteriorate	3	4	5	60	10	0.231	14
6	Combustion chamber (Fuel nozzle)	Flame-out	fuel nozzles obstruction or Partial cloggage	4	6	2	48	12	0.356	10
7	Combustion chamber (Flame tube)	Hot spots on flame tube	Flame tube cooling failure and uneven flame distribution around it	4	7	2	56	11	0.368	9
8	Turbine	Vibration	Defective vibration indication	5	6	6	180	5	0.457	6

Chapter IV: Risk evaluation approaches in failure mode and effects analysis

9	(Rotor)		Defective bearings	5	8	3	120	7	0.447	8
10	Ancillary system. (Fuel system components)	Over-speed	High fuel flow	6	7	5	210	4	0.5	5
11		No start	water ,Air, ,or particles in fuel lines	2	9	5	90	8	0.307	11
12		Stall	irregular fuel pressure	6	8	5	240	3	0.531	4
13	Ancillary system. (Electrical system components)	Faulty temperature indication	Open, short circuit in thermocouple circuit	6	9	3	162	6	0.572	3
14		Not reaching idle speed	Low electrical power	8	9	7	504	1	0.758	1
15		Defective speed indication	Internal tachometer failure	7	9	6	378	2	0.667	2

4.3.2. Failure mode analysis by an adaptive neural fuzzy inference system

This part describes the development of the ANFIS system to evaluate the failure modes for criticality ranking. A comparison with fuzzy criticality assessment methodology is also used to estimate the efficacy and validity of this model.

The number of membership functions (MFs) was defined for (5, 5, 5), representing that each input has five linguistic. To evaluate the relations between input, frequency, severity, and non-detection and output variables, trapezoidal and Gaussian membership functions were used.

The data is subdivided into two sets: the training and checking data set. The training process utilized equations (3.26, 3.27, 3.28, 3.29, and 3.30) of five layers; while, the checking data were have been used to verify that the trained ANFIS model was accurate and effective in adapting learning content. By using a hybrid method to update membership function

Chapter IV: Risk evaluation approaches in failure mode and effects analysis

parameters, training error was reduced. Then, checking data is utilized to test the fuzzy inference system's generalization capability at each epoch. The checking error keeps track of the RMSE at each epoch for the checking data.

Figures 4.10 and 4.11 present the trained and checked output of the ANFIS model; it can see that it looks satisfactory. The final training and checking error is produced (figure4.12), the graph represents the checking error on the top side, and the training error appears on the bottom. It also shows that training stopped in the 300nd epoch and the minimum checking error obtained for modeling system criticality evaluation is 0.0244.

The failure modes evaluation and ranking by the ANFIS system is shown in table 4.10 .

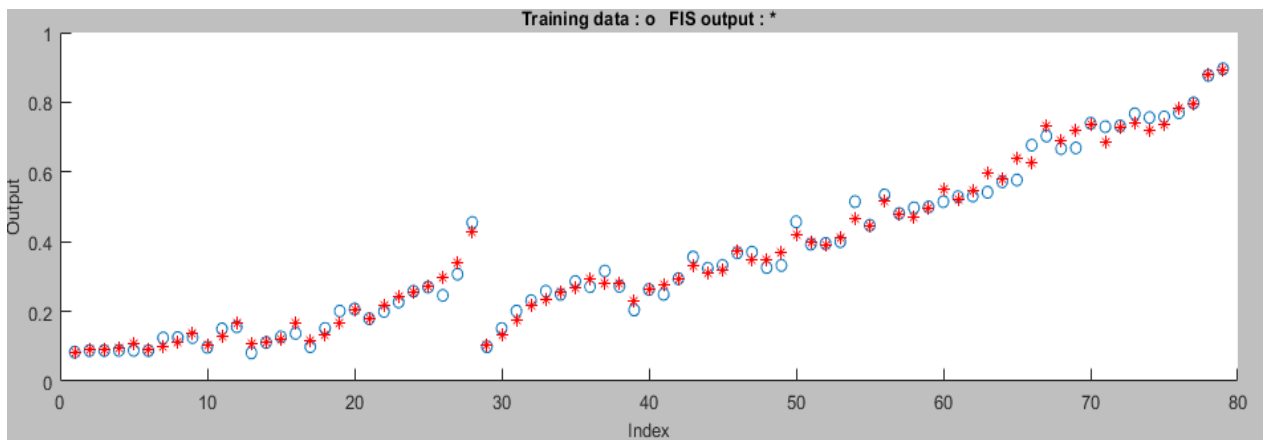

Figure 4.10 training data

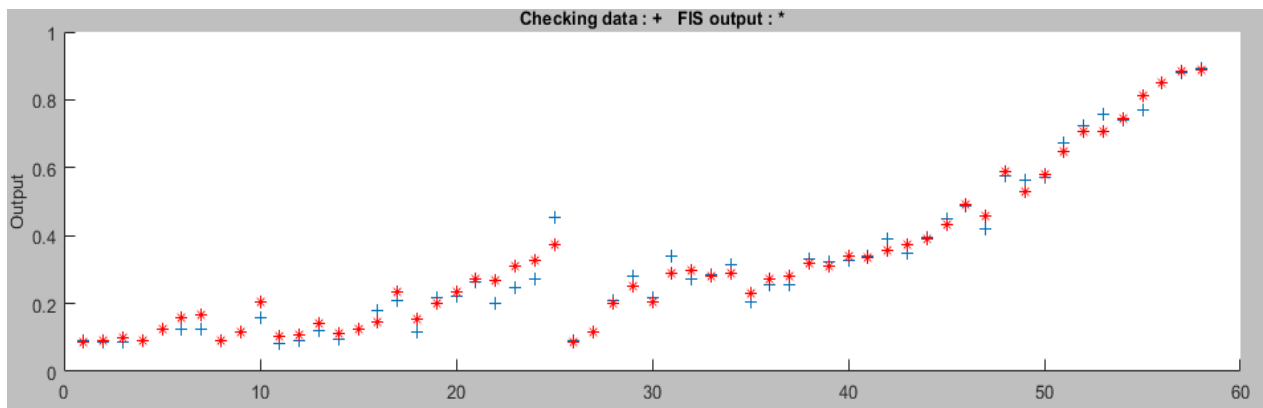

Figure 4.11 checking data

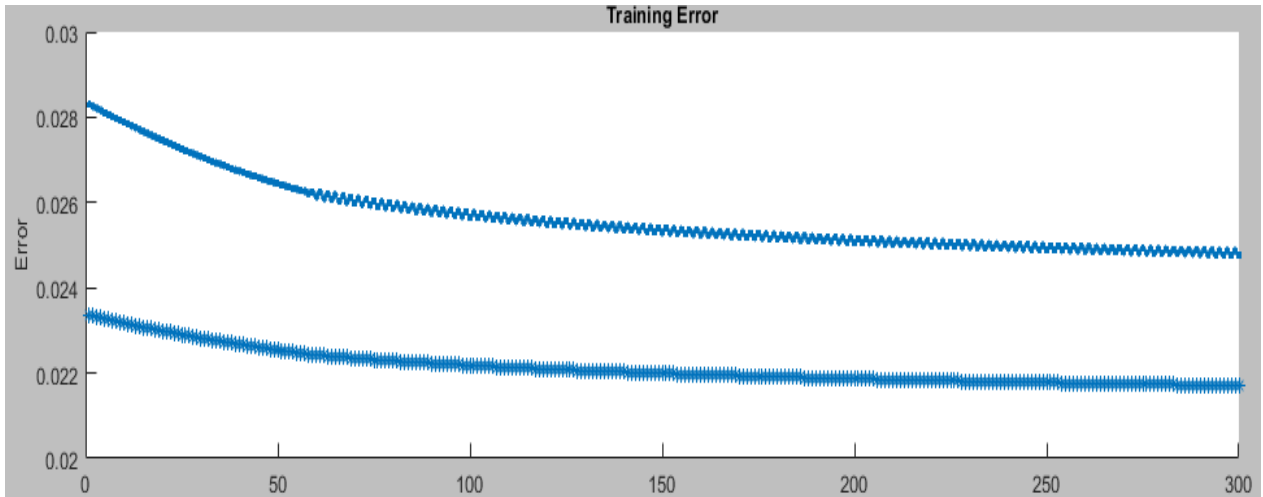

Figure 4.12 Training and checking data errors for the ANFIS model

Table 4.10 neuro-fuzzy RPN results

Failure mode Sequence N°	Item	Failure Mode	Failure Cause	F	S	D	ANFIS RPN output	RANK
1	Compressor (Rotor)	Vibration	Defective vibration indication	2	10	6	0.4355	7
2			Defective bearings	2	5	3	0.2191	15
3		Over-temperature	Compressor rotor dirty	3	5	4	0.2508	13
4	Compressor (Stator)	Stall	variable stator vanes Binding	3	6	4	0.2725	12
5			Foreign object deteriorate	3	4	5	0.2214	14
	Combustion	Flame-out	fuel nozzles obstruction	4	6	2	0.3333	11

Chapter IV: Risk evaluation approaches in failure mode and effects analysis

6	chamber (Fuel nozzle)		or Partial clogage					
7	Combustion chamber (Flame tube)	Hot spots on flame tube	Flame tube cooling failure and uneven flame distribution around it	4	7	2	0.3746	9
8	Turbine (Rotor)	Vibration	Defective vibration indication	5	6	6	0.4292	8
9			Defective bearings	5	8	3	0.4439	6
10	Ancillary system. (Fuel system components)	Over-speed	High fuel flow	6	7	5	0.4970	5
11		No start	water ,Air, ,or particles in fuel lines	2	9	5	0.3347	10
12		Stall	irregular fuel pressure	6	8	5	0.5378	4
13	Ancillary system. (Electrical system components)	Faulty temperature indication	Open, short circuit in thermocouple circuit	6	9	3	0.5792	3
14		Not reaching idle speed	Low electrical power	8	9	7	0.7406	1
15		Defective speed indication	Internal tachometer failure	7	9	6	0.6855	2

4.3.3. Failure mode analysis by Proposed Grey modeling

As mentioned previously, several shortcomings in using the FMECA method concerning the vagueness and subjectivity in failure modes assessment, other limitation regarding the lack of established inference rules which necessitate a good deal of expertise. As a result of different weight combinations, different ranking results may occur. It is improbable that all decision-makers will easily reach a consensus on an adequate set of weights. A new approach that combines the grey relational approach (GRA) and fuzzy analytic hierarchy process is suggested to solve these disadvantages. The suggested approach can be obtained by the following steps (figure 4.13).

4.3.3.1. Recognizing Comparative Series

The comparative series is an information series that includes values for the frequency, no-detection, and severity. The comparative series comprises the three factors above is presented following equation (3.10).

Where m denotes the criticality factors number and n is the failure modes number. $z_i(m)$ indicates the m^{th} factors of z_i and the n information series as shown in equation (3.11).

4.3.3.2. Standard series identification

The objective of identifying the standard series is to deduce the degree of relation; it represents the optimal level of all decision parameters. Standard series can be explained following equation (3.12).

4.3.3.4. Obtain the difference between comparative and standard series as shown in (3.13).

4.3.3.4. Compute the Grey Relationship Coefficient

Three failure mode criticality parameters are compared to the standard series. The Grey relational coefficient for F , ND and, S is calculated by flowing equation (3.14)

4.3.3.5. Integrate the weighted factors to determine the degree of relation

If each criticality factor has equal importance equation (3.15) is used to determine the degree of relation .If the criticality parameters have different importance equation 3.16 is used

Where $\beta(m)$ denotes the criticality factor weights. To calculate the risk factor weights fuzzy AHP Process was utilized in the next stage.

4.3.3.5. 1.Fuzzy Analytic Hierarchy Process

AHP has been designed by[89]. It is an effective method for resolving problems of decision. It ranks the importance of criteria using pair-wise comparisons. Buckley combined the AHP into fuzzy theory, called Fuzzy AHP[90] .In fuzzy AHP, to respond with ambiguity and subjectivity in pair-wise comparison, the ability of AHP has been improved. Instead of a

Chapter IV: Risk evaluation approaches in failure mode and effects analysis

crisp value, fuzzy AHP utilizes a domain of values to combine the decision maker's uncertainties [91]. The Fuzzy Analytic Hierarchy process procedure is presented as follows:

- *Step 1:* A pair-wise comparison matrix is created, as shown in equation 3.7. Using expert questionnaires, the expert is requested to give linguistic variables to pair-wise comparisons across all criteria using triangular fuzzy numbers figure 3.2.
- *Step 2:* For each criterion, compute the fuzzy geometric mean as shown in equation 3.8.
- *Step 3:* Normalization is used to calculate the fuzzy weights. Equation 3.9 can be used to calculate the fuzzy weight of the i^{th} criteria :

4.3.3.6. Criticality Priority Ranking

The failure modes are ranked in ascending order by the degree of relation. The failure modes with the smallest degree of grey relation are given the most priority[92].

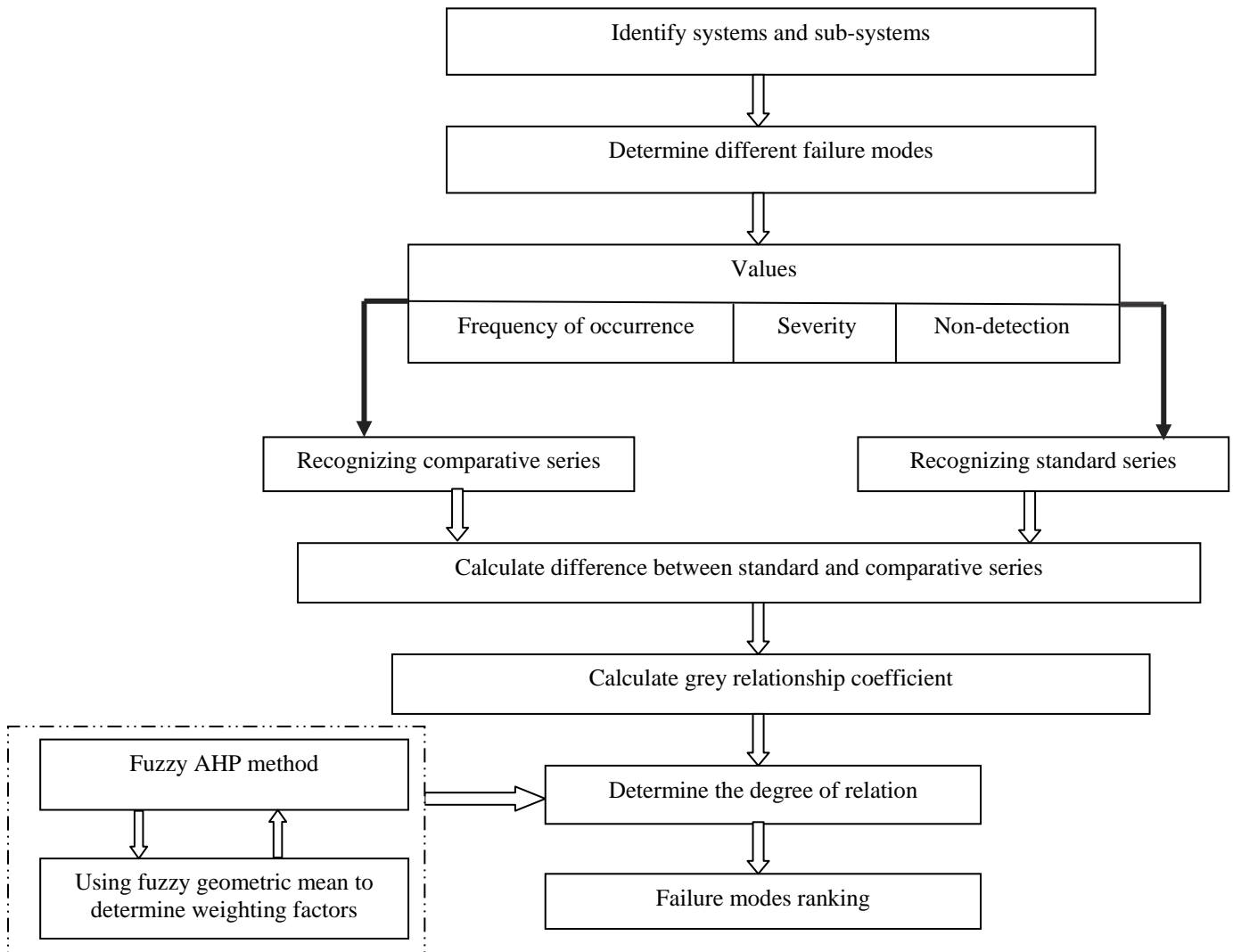

Figure 4.13 Flow chart of the proposed approach

Chapter IV: Risk evaluation approaches in failure mode and effects analysis

As a multi-criteria process, the criticality ranking is obtained by using the grey relational analyses. This latter is used to produce the prioritization strategy and replaced the rule base utilized in the fuzzy system. Grey relational analyses method was used in order to resolve these problems for rank and prioritize the failures mode effectively in the lack of a rule establishment.

FMECA data from table 4.9 is used in this section, and the GRA method is applied with various cases (criticality parameters have different and equal weights). FAHP method is used for determining the criticality factors weights based on expert decisions.

The first step is to establish comparative series according to different factors, frequency, severity, and non-detection by the following matrix.

$$\begin{bmatrix} z_1(1) & z_1(2) & z_1(3) \\ z_2(1) & z_2(2) & z_2(3) \\ \\ z_8(1) & z_8(2) & z_8(3) \\ \\ z_{14}(1) & z_{14}(2) & z_{14}(3) \\ z_{15}(1) & z_{15}(2) & z_{15}(3) \end{bmatrix} = \begin{bmatrix} 2 & 10 & 6 \\ 2 & 5 & 3 \\ \\ 5 & 6 & 6 \\ \\ 8 & 9 & 7 \\ 7 & 9 & 6 \end{bmatrix} \quad (4.2)$$

Equation 3.13 yields the difference between the standard and comparative series, which is represented as the matrix below.

$$\begin{bmatrix} \Delta_{01}(1) & \Delta_{01}(2) & \Delta_{01}(3) \\ \Delta_{02}(1) & \Delta_{02}(2) & \Delta_{02}(3) \\ \cdot & \cdot & \cdot \\ \cdot & \cdot & \cdot \\ \Delta_{08}(1) & \Delta_{08}(2) & \Delta_{08}(3) \\ \cdot & \cdot & \cdot \\ \Delta_{014}(1) & \Delta_{014}(2) & \Delta_{014}(3) \\ \Delta_{015}(1) & \Delta_{015}(2) & \Delta_{015}(3) \end{bmatrix} = \begin{bmatrix} 1 & 9 & 5 \\ 1 & 4 & 2 \\ \cdot & \cdot & \cdot \\ \cdot & \cdot & \cdot \\ 4 & 5 & 5 \\ \cdot & \cdot & \cdot \\ 7 & 8 & 6 \\ 6 & 8 & 5 \end{bmatrix} \quad (4.3)$$

As previously mentioned the grey relationship coefficient is determined by the equation

$$3.14, \text{ According to the equation If } \Delta_{\max}=9, \Delta_{\min}=1 \text{ and } \zeta \text{ is } 0.5, \gamma_{0i}(k) = \frac{1 + 0.5 * 9}{\Delta_{0i}(k) + 0.5 * 9}$$

Chapter IV: Risk evaluation approaches in failure mode and effects analysis

$$\begin{bmatrix} \gamma_{01}(1) & \gamma_{01}(2) & \gamma_{01}(3) \\ \gamma_{02}(1) & \gamma_{02}(2) & \gamma_{02}(3) \\ \cdot & \cdot & \cdot \\ \cdot & \cdot & \cdot \\ \gamma_{08}(1) & \gamma_{08}(2) & \gamma_{08}(3) \\ \cdot & \cdot & \cdot \\ \gamma_{014}(1) & \gamma_{014}(2) & \gamma_{014}(3) \\ \gamma_{015}(1) & \gamma_{015}(2) & \gamma_{015}(3) \end{bmatrix} = \begin{bmatrix} 1 & 0.4 & 0.58 \\ 1 & 0.64 & 0.85 \\ \cdot & \cdot & \cdot \\ \cdot & \cdot & \cdot \\ 0.64 & 0.58 & 0.58 \\ \cdot & \cdot & \cdot \\ 0.48 & 0.44 & 0.52 \\ 0.52 & 0.44 & 0.58 \end{bmatrix} \quad (4.4)$$

If all criticality parameters are given equal weights, equation 3.15 is applied to find the relation degree. For example; the 1st failure mode is determined as;

$$\tau_i(k) = \frac{1}{3}(\gamma_{01}(1) + \gamma_{01}(2) + \gamma_{01}(3)) = \frac{1}{3}(1 + 0.4 + 0.58) = 0.660$$

The second case is the factors have different weights; the fuzzy AHP method is called to specify weights to the criticality parameters. Experts have compared the importance of the criticality factors with triangular fuzzy values to overcome the uncertainty associated with the experts' judgment. The fuzzy AHP scales are shown in the appendix E. The pairwise comparison is given as:

$$\begin{bmatrix} 1,1,1 & \frac{1}{7}, \frac{1}{6}, \frac{1}{5} & \frac{1}{9}, \frac{1}{9}, \frac{1}{8} \\ 5,6,7 & 1,1,1 & \frac{1}{9}, \frac{1}{8}, \frac{1}{7} \\ 8,9,9 & 7,8,9 & 1,1,1 \end{bmatrix} \quad (4.5)$$

Then the geometric mean method is used to calculate the fuzzy weight for each criterion by using (equation 3.8, 3.9), the results shown in table 4.11.

Table 4.11 Fuzzy pair wise comparisons to calculate weights

	Frequency	Non-detection	Severity	Fuzzy geometric mean value r_i	Fuzzy weights w_i
Frequency	(1,1,1)	$(\frac{1}{7}, \frac{1}{6}, \frac{1}{5})$	$(\frac{1}{9}, \frac{1}{9}, \frac{1}{8})$	(0.251 0.264 0.292)	0.05
Non-detection	(5,6,7)	(1,1,1)	$(\frac{1}{9}, \frac{1}{8}, \frac{1}{7})$	(0.822 0.908 1)	0.173
Severity	(8,9,9)	(7,8,9)	(1,1,1)	(3.825 4.16 4.32)	0.777

So the weights of the frequency, detection, and severity are 0.05, 0.173, 0.777 respectively. Through Eq(3.16), the degree of relation is obtained and the all results shown in table 4.12.

Chapter IV: Risk evaluation approaches in failure mode and effects analysis

Table 4.12 Ranking comparison between conventional, fuzzy, ANFIS and GRA proposed approach

Failure mode N°	Failure Mode	Failure Cause	F	S	D	Conventional RPN	rank	fuzzy RPN	Rank	ANFIS RPN	Rank	GRA with similar weighs	Rank	GRA with different Weights	Rank
1	Vibration	Defective vibration indication	2	10	6	120	7	0.455	7	0.435	7	0.660	8	0.461	2
2		Defective bearings	2	5	3	30	13	0.200	15	0.219	15	0.831	14	0.622	11
3	Over-temperature	Compressor rotor dirty	3	5	4	60	10	0.249	13	0.250	13	0.737	11	0.666	14
4	Stall	variable stator vanes Binding	3	6	4	72	9	0.272	12	0.272	12	0.718	10	0.619	10
5		Foreign object deteriorate	3	4	5	60	10	0.231	14	0.221	14	0.737	11	0.600	9
6	Flame-out	fuel nozzles obstruction or Partial cloggage	4	6	2	48	12	0.356	10	0.333	11	0.771	13	0.660	13
7	Hot spots on flame tube	Flame tube cooling failure and uneven flame distribution around it	4	7	2	56	11	0.368	9	0.374	9	0.751	12	0.649	12
8	Vibration	Defective vibration indication	5	6	6	180	5	0.457	6	0.429	8	0.567	3	0.583	8
9		Defective bearings	5	8	3	120	7	0.447	8	0.443	6	0.653	7	0.544	7
10	Over-speed	High fuel flow	6	7	5	210	4	0.500	5	0.497	5	0.580	4	0.544	7
11	No start	water ,Air,or particles in	2	9	5	90	8	0.307	11	0.334	10	0.693	9	0.500	4

Chapter IV: Risk evaluation approaches in failure mode and effects analysis

		fuel lines													
12	Stall	irregular fuel pressure	6	8	5	240	3	0.531	4	0.537	4	0.600	5	0.512	5
13	Faulty temperature indication	Open, short circuit in thermocouple circuit	6	9	3	162	6	0.572	3	0.579	3	0.620	6	0.516	6
14	Not reaching idle speed	Low electrical power	8	9	7	504	1	0.758	1	0.740	1	0.480	1	0.456	1
15	Defective speed indication	Internal tachometer failure	7	9	6	378	2	0.667	2	0.685	2	0.513	2	0.468	3

Results and discussion

Table 4.12 represents the results of the various methods of analysis for the gas turbine system. As seen previously in the conventional FMECA method, the RPN number is estimated by multiplying each failure mode's factor scores. The system FMECA assists us in producing prevention both at the functioning levels and system conception to prevent the failure mode criticality. Then, a similar strategy is used for other elements and sub-systems. According to the findings, safety amelioration activities at various stages of processes were proposed.

As shown in Table 4.12 that the ranking of failures mode acquired from the classical FMECA is arranged as FM₁₄, FM₁₅, FM₁₂, FM₁₀, FM₈, FM₁₃, (FM₉, FM₁), FM₁₁, FM₄, (FM₅, FM₃), FM₇, FM₆, FM₂, respectively. While, after using fuzzy criticality evaluation gave a new ranking of the failures mode. For instance, in the conventional method, FM₁₃ is placed in the sixth ranking. However, it classifies at the third ranking in the fuzzy approach. At the same time, in both the approaches, FM₁₄ is the farthest critical mode.

By comparing the classical results of FMECA with the fuzzy approach, the limitations associated with traditional FMECA can clearly observed; the most critical drawback of the conventional method is that the different combinations of three parameters ratings generate a similar RPN value; while, the criticality representations can be dissimilar, For example, FM₃ and FM₅ have the same RPN of 60, while the criticality consequences of any of these events can not precisely be the same, but the fuzzy inference differs in those, and it would be helpful for defining priority on those causes. The second constraint of the classical method

Chapter IV: Risk evaluation approaches in failure mode and effects analysis

ignores the importance between F, ND, and S factors. The three inputs are supposed to have equal importance but the relative importance between the inputs exists in real applications; for example, as shown in table FM₁₃ with a moderate probability of occurrence, very high severity, and low detection (6, 9, 3) with a lower RPN of 162 than one with all parameters moderate as FM₈ (5, 6, 6) with RPN 180; Conversely with the fuzzy system inference can be clearly showed that FM₁₃ has a higher value than FM₈ with values 0.572, 0.457 respectively, and so will be have a higher priority for corrective-preventive measures.

To compare and evaluate the efficiency and validity of the performances of the fuzzy criticality assessment approach, which considers the evaluation process's uncertainty and ambiguity and gives a more reliable solution, an ANFIS ranking model shown in table 4.12 that the failure modes' priority ranking obtained is approximate to the one determined by the fuzzy approach except for a few failure modes whose priority order is reorganized. The ANFIS system also shows that it can competently predict criticality assessment of failures mode.

Regarding the proposed grey relation analysis approach, the priority order has been noticed to vary compared with the previous approach. For instance FM₁₄, FM₁₅ have higher ranking importance in all approaches (the most critical failures mode). However, FM₁₃ has lower ranking importance in the proposed approach and a higher ranking in other approaches. The significant reasons are explained by the various criticality evaluation approaches and ranking processes used in such methods.

Table 4.12 shows the weightage or importance of the three parameters frequency, non detection, and severity among the grey proposed approach. The importance weights are being used to make the proposed FMECA methodology more efficient, realistic, and adaptive. When different weighting factors are used, there is a remarkable rearranging in the failure modes ranking, indicating their significance. Changing the weights can be easy to readjust the approach in the situation of requests resulting from changes or variations. The grey relation method is utilized in the lack of specified inference rules that necessitate a lot of experience.

4.4. Conclusion

It can be concluded that the results obtained by the use multi-criteria decision making (MCDM) approaches and artificial intelligence model of gas turbine and LPG storage system showed the effectiveness of the proposed modeling to improve the use of the conventional FMECA regarding the criticality estimation and improve decision-making by prioritizing

Chapter IV: Risk evaluation approaches in failure mode and effects analysis

“preventive –corrective actions” and determine the efficient action for each partial criticality to control the risk

The obtained results show that the integration of two multi-criteria decision methods and incorporating their results enable to instill confidence in decision-makers

this case study application is providing encouraging results regarding the risk evaluation and prioritizing failures mode and decision makers guidance to refine the relevance of decision making in order to reduce the probability of occurrence and the severity of the undesirable scenarios with handling different forms of ambiguity, uncertainty, and divergent judgments of experts

GENERAL CONCLUSION

The main purpose of this work is to improve the use of the conventional failure mode, effects, and criticality analysis as a decision support tool in the field of dependability by study the contribution of fuzzy artificial intelligence (Adaptive neuro-fuzzy inference system and Fuzzy logic) and multi-criteria decision making methods the grey relational approach (GRA) and fuzzy analytic hierarchy in the risk evaluation and prioritizing failures mode and decision makers guidance to refine the relevance of decision making in order to reduce the probability of occurrence and the severity of the undesirable scenarios with handling different forms of ambiguity, uncertainty, and divergent judgments of experts

Realized work

The proposed approaches were used in this work is to improve the decision making regarding to the criticality assessment and prioritize failure modes perfectly to prefer actions for controlling the risks of undesirable scenarios.

Compared with the conventional method, the merits of fuzzy based criticality assessment methodology allow experts to more flexibly and objectively combine the frequency, non-detectability, and severity of failures mode by using their judgment to overcome the difficulties arising in performing the standard FMECA procedure.

The inference engines, although simple in this case, made it possible to capitalize on the experience of the company. The different rules (R_i) constructed have allowed popularizing the influence of the FMECA parameters on each criticality. This gave more credibility to the criticality analysis since it is no longer about multiplying factors but rather building a conditional structure leading to significant criticalities.

Our contribution adds a more factual vision in the field of dependability. Indeed, the interactions of systems based on fuzzy logic and multi-criteria decision analysis (AHP) allow better appreciating of criticality and guiding decision-makers to anticipate internal and external effects. This approach is particularly tolerant with inaccuracies of input data; the rejection of contradictory information is then reduced.

Fuzzy Analytic Hierarchy and GRA methods are used together in this work to evaluate and rank the criticality more realistic and effective. The findings may offer essential conclusions in the decision-making process. The results show that the integration of FAHP and GRA method can provide a more precise, acceptable criticality ranking order. Additionally, the usage of the suggested approach can be utilized when the preset inference

rules are insufficient which ordinarily necessitate a great deal of experience. This model is easily adjusted to process changes which raise the approach's applicability

Case study of LPG storage and gas turbine system showed the applicability of the proposed modellings by providing encouraging results regarding the estimation of criticality and decision-makers' guidance to refine the relevance of decision making. This was decisive in convincing the company to take the actions cited above and choose the best choice from the different alternatives in order to reduce the frequency of occurrence and the severity of the undesirable scenarios and improve the detectability.

This research work offers new future research and many possible perspectives. It will focus on using artificial intelligence techniques in integration with multi-criteria decision-making methods to improve the abilities of FMECA. Algorithms of deep learning will be utilized to learn criticality parameters weights from the criticality evaluations and optimize the number of inference rules, using learning and observations on the results of criticalities and the effects of decision types. For the failure modes, neural networks can also enable multi criteria decision-making methods to reflect variation in the criticality ranking.

REFERENCE

- [1] S. Kabir, "An overview of fault tree analysis and its application in model based dependability analysis," *Expert systems with applications*, vol. 77, pp. 114-135, 2017.
- [2] A. Bondavalli, M. Dal Cin, D. Latella, I. Majzik, A. Pataricza, and G. Savoia, "Dependability analysis in the early phases of UML-based system design," *Comput. Syst. Sci. Eng.*, vol. 16, pp. 265-275, 2001.
- [3] R. kamal Kaur, B. Pandey, and L. K. Singh, "Dependability analysis of safety critical systems: Issues and challenges," *Annals of Nuclear Energy*, vol. 120, pp. 127-154, 2018.
- [4] S. Bernardi, J. Merseguer, and D. C. Petriu, "Dependability analysis techniques," in *Model-driven dependability assessment of software systems*, ed: Springer, 2013, pp. 73-90.
- [5] A. Avizienis, J.-C. Laprie, and B. Randell, "Fundamental concepts of dependability," *Department of Computing Science Technical Report Series*, 2001.
- [6] A. Avizienis, J.-C. Laprie, and B. Randell, "Dependability and its threats: a taxonomy," in *Building the Information Society*, ed: Springer, 2004, pp. 91-120.
- [7] F. Guérin, B. Dumon, and E. Usureau, "Reliability estimation by Bayesian method: definition of prior distribution using dependability study," *Reliability Engineering & System Safety*, vol. 82, pp. 299-306, 2003.
- [8] P. Weber, G. Medina-Oliva, C. Simon, and B. Iung, "Overview on Bayesian networks applications for dependability, risk analysis and maintenance areas," *Engineering Applications of Artificial Intelligence*, vol. 25, pp. 671-682, 2012.
- [9] S. Kabir and Y. Papadopoulos, "Applications of Bayesian networks and Petri nets in safety, reliability, and risk assessments: A review," *Safety science*, vol. 115, pp. 154-175, 2019.
- [10] X. Liu, M. Shahidehpour, Y. Cao, Z. Li, and W. Tian, "Risk assessment in extreme events considering the reliability of protection systems," *IEEE Transactions on Smart Grid*, vol. 6, pp. 1073-1081, 2015.
- [11] M. Bougofa, M. Taleb-Berrouane, A. Bouafia, A. Baziz, R. Kharzi, and A. Bellaouar, "Dynamic availability analysis using dynamic Bayesian and evidential networks," *Process Safety and Environmental Protection*, vol. 153, pp. 486-499, 2021.
- [12] M. Bougofa, A. Bouafia, and A. Bellaouar, "An Integrated Quantitative Bayesian Network in Risk Management for Complex Systems," *International Journal of Performability Engineering*, 2020.

- [13] S. Wang, K. Pei, J. Whitehouse, J. Yang, and S. Jana, "Efficient formal safety analysis of neural networks," *Advances in Neural Information Processing Systems*, vol. 31, 2018.
- [14] D. Choudhary, M. Tripathi, and R. Shankar, "Reliability, availability and maintainability analysis of a cement plant: a case study," *International Journal of Quality & Reliability Management*, 2019.
- [15] P. Tsarouhas, "Reliability, availability and maintainability (RAM) analysis for wine packaging production line," *International Journal of Quality & Reliability Management*, 2018.
- [16] G. Signoretti, M. Silva, J. Araujo, I. Silva, D. Silva, P. Ferrari, and E. Sisinni, "A dependability evaluation for obd-ii edge devices: An internet of intelligent vehicles perspective," in *2019 9th Latin-American Symposium on Dependable Computing (LADC)*, 2019, pp. 1-9.
- [17] Z. Al-Makhadmeh and A. Tolba, "Dependable information processing method for reliable human-robot interactions in smart city applications," *Image and Vision Computing*, vol. 104, p. 104045, 2020.
- [18] D. Brefort, C. Shields, A. H. Jansen, E. Duchateau, R. Pawling, K. Droste, T. Jasper, M. Sypniewski, C. Goodrum, and M. A. Parsons, "An architectural framework for distributed naval ship systems," *Ocean Engineering*, vol. 147, pp. 375-385, 2018.
- [19] D. Dori, H. Sillitto, R. M. Griego, D. McKinney, E. P. Arnold, P. Godfrey, J. Martin, S. Jackson, and D. Krob, "System definition, system worldviews, and systemness characteristics," *IEEE Systems Journal*, vol. 14, pp. 1538-1548, 2019.
- [20] J. Chen, P.-A. Zhong, R. An, F. Zhu, and B. Xu, "Risk analysis for real-time flood control operation of a multi-reservoir system using a dynamic Bayesian network," *Environmental modelling & software*, vol. 111, pp. 409-420, 2019.
- [21] H.-C. Liu, *Improved FMEA methods for proactive healthcare risk analysis*: Springer, 2019.
- [22] G. Herrera Vidal and J. R. Coronado Hernández, "Complexity in manufacturing systems: a literature review," *Production Engineering*, vol. 15, pp. 321-333, 2021.
- [23] B. Alkan and S. Bullock, "Assessing operational complexity of manufacturing systems based on algorithmic complexity of key performance indicator time-series," *Journal of the Operational Research Society*, vol. 72, pp. 2241-2255, 2021.
- [24] N. Southern, "Creating leaders for systems complexity," *Handbook of Systems Sciences*, pp. 1-29, 2020.
- [25] G. Punzo, A. Tewari, E. Butans, M. Vasile, A. Purvis, M. Mayfield, and L. Varga, "Engineering resilient complex systems: the necessary shift toward complexity science," *IEEE Systems Journal*, vol. 14, pp. 3865-3874, 2020.

- [26] S. Wolfram, "Complex Systems Theory 1," in *Emerging syntheses in science*, ed: CRC Press, 2018, pp. 183-190.
- [27] K. M. Pepin, M. W. Hopken, S. A. Shriner, E. Spackman, Z. Abdo, C. Parrish, S. Riley, J. O. Lloyd-Smith, and A. J. Piaggio, "Improving risk assessment of the emergence of novel influenza A viruses by incorporating environmental surveillance," *Philosophical Transactions of the Royal Society B*, vol. 374, p. 20180346, 2019.
- [28] K.-H. Zeng, S.-H. Chou, F.-H. Chan, J. Carlos Niebles, and M. Sun, "Agent-centric risk assessment: Accident anticipation and risky region localization," in *Proceedings of the IEEE Conference on Computer Vision and Pattern Recognition*, 2017, pp. 2222-2230.
- [29] R. Jena, B. Pradhan, G. Beydoun, H. Sofyan, and M. Affan, "Integrated model for earthquake risk assessment using neural network and analytic hierarchy process: Aceh province, Indonesia," *Geoscience Frontiers*, vol. 11, pp. 613-634, 2020.
- [30] C. Young and K. Holsteen, "Model uncertainty and robustness: A computational framework for multimodel analysis," *Sociological Methods & Research*, vol. 46, pp. 3-40, 2017.
- [31] R. Haberfellner, P. Nagel, M. Becker, A. Büchel, and H. von Massow, *Systems engineering*: Springer, 2019.
- [32] M. Jamshidi, *Systems of systems engineering: principles and applications*: CRC press, 2017.
- [33] A. W. Wymore, *Model-based systems engineering*: CRC press, 2018.
- [34] M. Z. Hauschild, R. K. Rosenbaum, and S. I. Olsen, *Life cycle assessment*: Springer, 2018.
- [35] M. K. Parr and A. H. Schmidt, "Life cycle management of analytical methods," *Journal of Pharmaceutical and Biomedical Analysis*, vol. 147, pp. 506-517, 2018.
- [36] N. Wang, R. Shen, Z. Wen, and D. De Clercq, "Life cycle energy efficiency evaluation for coal development and utilization," *Energy*, vol. 179, pp. 1-11, 2019.
- [37] A. J. Carpio-de Los Pinos and M. d. L. N. González-García, "Development of the protocol of the occupational risk assessment method for construction works: Level of Preventive Action," *International journal of environmental research and public health*, vol. 17, p. 6369, 2020.
- [38] U. Force, D. Owens, K. Davidson, A. Krist, M. Barry, M. Cabana, A. Caughey, C. Doubeni, J. Epling Jr, and M. Kubik, "Risk Assessment," *Genetic Counseling, and Genetic Testing for BRCA-Related Cancer: US Preventive Services Task Force Recommendation Statement. JAMA*, vol. 322, pp. 652-665, 2019.

- [39] M. Mazilu and S. Ispas, "The Exigencies of Environmental Protection Against the Vulnerabilities of Natural Disasters," in *Advanced Engineering Forum*, 2015, pp. 241-248.
- [40] H. Subramanyan, P. H. Sawant, and V. Bhatt, "Construction project risk assessment: development of model based on investigation of opinion of construction project experts from India," *Journal of Construction Engineering and Management*, vol. 138, pp. 409-421, 2012.
- [41] M. H. Ammar, M. Benaïssa, and H. Chabchoub, "Traceability management system: Literature review and proposal of a system integrating risk management for hazardous products transportation," in *2015 4th International Conference on Advanced Logistics and Transport (ICALT)*, 2015, pp. 229-234.
- [42] W. Ho, T. Zheng, H. Yildiz, and S. Talluri, "Supply chain risk management: a literature review," *International Journal of Production Research*, vol. 53, pp. 5031-5069, 2015.
- [43] P. Hopkin, *Risk management*: Kogan Page Publishers, 2013.
- [44] R. Ramesh, M. Prabu, S. Magibalan, and P. Senthilkumar, "Hazard identification and risk assessment in automotive industry," *International journal of ChemTech research*, vol. 10, pp. 352-358, 2017.
- [45] Y. Y. Haimes, "On the complex definition of risk: A systems-based approach," *Risk Analysis: An International Journal*, vol. 29, pp. 1647-1654, 2009.
- [46] D. Bernoulli, "Specimen theoriae novae de mensura sortis," 1967.
- [47] Q. Gong and S. Tan, "Risk Rating Method Based on the Severity Probability Risk Value and Reserved Risk Maintenance Resource Cost of the Node Disconnection of the Power System," *Processes*, vol. 7, p. 307, 2019.
- [48] D. Sarnytska, "Risks in the field of the enterprise," in *Tezele celei de-a 74-a conferință științifică a studenților*, 2021, pp. 171-171.
- [49] J. A. L. Anjalee, V. Rutter, and N. R. Samaranayake, "Application of Failure Mode and Effect Analysis (FMEA) to improve medication safety: a systematic review," *Postgraduate Medical Journal*, vol. 97, pp. 168-174, 2021.
- [50] A. P. Subriadi and N. F. Najwa, "The consistency analysis of failure mode and effect analysis (FMEA) in information technology risk assessment," *Heliyon*, vol. 6, p. e03161, 2020.
- [51] S. Carpitella, A. Certa, J. Izquierdo, and C. M. La Fata, "A combined multi-criteria approach to support FMECA analyses: A real-world case," *Reliability Engineering & System Safety*, vol. 169, pp. 394-402, 2018.
- [52] I. Mzougui, S. Carpitella, A. Certa, Z. El Felsoufi, and J. Izquierdo, "Assessing supply chain risks in the automotive industry through a modified MCDM-based FMECA," *Processes*, vol. 8, p. 579, 2020.

- [53] S. Kabir, T. K. Geok, M. Kumar, M. Yazdi, and F. Hossain, "A method for temporal fault tree analysis using intuitionistic fuzzy set and expert elicitation," *Ieee Access*, vol. 8, pp. 980-996, 2019.
- [54] P. Badida, Y. Balasubramaniam, and J. Jayaprakash, "Risk evaluation of oil and natural gas pipelines due to natural hazards using fuzzy fault tree analysis," *Journal of Natural Gas Science and Engineering*, vol. 66, pp. 284-292, 2019.
- [55] S. Shoar, F. Nasirzadeh, and H. R. Zarandi, "Quantitative assessment of risks on construction projects using fault tree analysis with hybrid uncertainties," *Construction Innovation*, 2019.
- [56] M. J. Jafari, M. Pouyakian, and S. M. Hanifi, "Reliability evaluation of fire alarm systems using dynamic Bayesian networks and fuzzy fault tree analysis," *Journal of Loss Prevention in the Process Industries*, vol. 67, p. 104229, 2020.
- [57] J. H. Purba, D. S. Tjahyani, S. Widodo, and A. S. Ekariansyah, "Fuzzy probability based event tree analysis for calculating core damage frequency in nuclear power plant probabilistic safety assessment," *Progress in Nuclear Energy*, vol. 125, p. 103376, 2020.
- [58] E. Momeni, M. Poormoosavian, H. S. Tehrani, and A. Fakher, "Reliability analysis and risk assessment of deep excavations using random-set finite element method and event tree technique," *Transportation Geotechnics*, vol. 29, p. 100560, 2021.
- [59] F. Piadeh, M. Ahmadi, and K. Behzadian, "Reliability assessment for hybrid systems of advanced treatment units of industrial wastewater reuse using combined event tree and fuzzy fault tree analyses," *Journal of Cleaner Production*, vol. 201, pp. 958-973, 2018.
- [60] T. Zwęgliński, "Conventional Event Tree Analysis on Emergency Release of Liquefied Natural Gas," *International journal of environmental research and public health*, vol. 19, p. 2961, 2022.
- [61] S. Kabir, M. Walker, and Y. Papadopoulos, "Dynamic system safety analysis in HiP-HOPS with Petri Nets and Bayesian Networks," *Safety science*, vol. 105, pp. 55-70, 2018.
- [62] D. Yan, S. Guha, C. Ahn, and R. Tiwari, "Semiparametric Bayesian Markov analysis of personalized benefit–risk assessment," *The Annals of Applied Statistics*, vol. 14, pp. 768-788, 2020.
- [63] H.-C. Liu, X.-Q. Chen, C.-Y. Duan, and Y.-M. Wang, "Failure mode and effect analysis using multi-criteria decision making methods: A systematic literature review," *Computers & Industrial Engineering*, vol. 135, pp. 881-897, 2019.
- [64] H.-C. Liu, L.-E. Wang, X.-Y. You, and S.-M. Wu, "Failure mode and effect analysis with extended grey relational analysis method in cloud setting," *Total Quality Management & Business Excellence*, vol. 30, pp. 745-767, 2019.

- [65] A. Darko, A. P. C. Chan, E. E. Ameyaw, E. K. Owusu, E. Pärn, and D. J. Edwards, "Review of application of analytic hierarchy process (AHP) in construction," *International journal of construction management*, vol. 19, pp. 436-452, 2019.
- [66] A. u. Rehman, A. Shekhovtsov, N. Rehman, S. Faizi, and W. Salabun, "On the analytic hierarchy process structure in group decision-making using incomplete fuzzy information with applications," *Symmetry*, vol. 13, p. 609, 2021.
- [67] F. Kutlu Gündoğdu and C. Kahraman, "A novel spherical fuzzy analytic hierarchy process and its renewable energy application," *Soft Computing*, vol. 24, pp. 4607-4621, 2020.
- [68] A. Bademlioglu, A. Canbolat, and O. Kaynakli, "Multi-objective optimization of parameters affecting Organic Rankine Cycle performance characteristics with Taguchi-Grey Relational Analysis," *Renewable and Sustainable Energy Reviews*, vol. 117, p. 109483, 2020.
- [69] S. K. Jeong, C. H. Han, L. Hua, and W. K. Wibowo, "Systematic design of membership functions for fuzzy logic control of variable speed refrigeration system," *Applied Thermal Engineering*, vol. 142, pp. 303-310, 2018.
- [70] M. L. Lagunes, O. Castillo, F. Valdez, J. Soria, and P. Melin, "Parameter optimization for membership functions of type-2 fuzzy controllers for autonomous mobile robots using the firefly algorithm," in *North American fuzzy information processing society annual conference*, 2018, pp. 569-579.
- [71] L. A. Zadeh, G. J. Klir, and B. Yuan, *Fuzzy sets, fuzzy logic, and fuzzy systems: selected papers vol. 6*: World Scientific, 1996.
- [72] L. A. Zadeh and R. A. Aliev, *Fuzzy logic theory and applications: part I and part II*: World Scientific Publishing, 2018.
- [73] N. Sabri, S. Aljunid, M. Salim, R. Badlishah, R. Kamaruddin, and M. Malek, "Fuzzy inference system: Short review and design," *Int. Rev. Autom. Control*, vol. 6, pp. 441-449, 2013.
- [74] K. Kalaiarasi, M. S. Begum, and M. Sumathi, "Optimization of unconstrained multi-item (EPQ) model using fuzzy geometric programming with varying fuzzification and defuzzification methods by applying python," *Materials Today: Proceedings*, 2021.
- [75] A. H. Ganesh and A. H. Shobana, "On optimizing interval data based critical path problem for the analysis of various fuzzy quantities using fuzzification and centroid based defuzzification techniques," *Mat. S (1)*, pp. 319-330, 2020.
- [76] M. OUANID and A. Hassini, "Design and Development of an Embedded Fire Detection System using Neural Networks," *Journal of Telecommunication, Electronic and Computer Engineering (JTEC)*, vol. 13, pp. 9-15, 2021.

- [77] P. Cortés-Antonio, I. Batyrshin, A. Martínez-Cruz, L. A. Villa-Vargas, M. A. Ramírez-Salinas, I. Rudas, O. Castillo, and H. Molina-Lozano, "Learning rules for Sugeno ANFIS with parametric conjunction operations," *Applied Soft Computing*, vol. 89, p. 106095, 2020.
- [78] H. Alawad, M. An, and S. Kaewunruen, "Utilizing an adaptive neuro-fuzzy inference system (ANFIS) for overcrowding level risk assessment in railway stations," *Applied Sciences*, vol. 10, p. 5156, 2020.
- [79] K. Suresh and R. Dillibabu, "An integrated approach using IF-TOPSIS, fuzzy DEMATEL, and enhanced CSA optimized ANFIS for software risk prediction," *Knowledge and Information Systems*, vol. 63, pp. 1909-1934, 2021.
- [80] M. Kordestani, M. Rezamand, R. Carriveau, D. S. Ting, and M. Saif, "Failure diagnosis of wind turbine bearing using feature extraction and a neuro-fuzzy inference system (ANFIS)," in *International Work-Conference on Artificial Neural Networks*, 2019, pp. 545-556.
- [81] A. Chakhrit and M. Chennoufi, "Fuzzy multi-criteria approach for criticality assessment and optimization of decision making," *Journal of Intelligent & Fuzzy Systems*, pp. 1-16, 2021.
- [82] M. Miloud and L. Zoubida, "The Simulation of Removal Hydrogen Sulfide from Liquefied Petroleum Gas by Software ASPEN HYSYS V8. 8."
- [83] F. Lin, "Construction network ventilation system for underground LPG storage cavern," *Civil Engineering Journal*, vol. 4, pp. 1521-1541, 2018.
- [84] I. H. Guetarni, N. Aissani, E. Châtelet, and Z. Lounis, "Reliability analysis by mapping probabilistic importance factors into bayesian belief networks for making decision in water deluge system," *Process Safety Progress*, vol. 38, p. e12011, 2019.
- [85] K. Sarvestani, O. Ahmadi, and M. J. Alenjareghi, "LPG Storage Tank Accidents: Initiating Events, Causes, Scenarios, and Consequences," *Journal Of Failure Analysis And Prevention*, vol. 21, pp. 1305-1314, 2021.
- [86] A. Chakhrit and M. Chennoufi, "Failure mode, effects and criticality analysis improvement by using new criticality assessment and prioritization based approach," *Journal of Engineering, Design and Technology*, 2021.
- [87] B. Li, S.-s. Wang, K. Wang, and L. Song, "Comparative investigation on the supercritical carbon dioxide power cycle for waste heat recovery of gas turbine," *Energy Conversion and Management*, vol. 228, p. 113670, 2021.
- [88] M. Taleb-Berrouane, F. Khan, and M. Kamil, "Dynamic RAMS analysis using advanced probabilistic approach," *Chem Eng Trans*, vol. 77, pp. 241-246, 2019.
- [89] T. L. Saaty, "Transport planning with multiple criteria: the analytic hierarchy process applications and progress review," *Journal of advanced transportation*, vol. 29, pp. 81-126, 1995.

- [90] A. Hassan, M. R. A. Purnomo, and A. R. Anugerah, "Fuzzy-analytical-hierarchy process in failure mode and effect analysis (FMEA) to identify process failure in the warehouse of a cement industry," *Journal of Engineering, Design and Technology*, 2019.
- [91] M. S. Hellas, R. Chaib, and I. Verzea, "Artificial intelligence treating the problem of uncertainty in quantitative risk analysis (QRA)," *Journal of Engineering, Design and Technology*, 2019.
- [92] A. M. Kumar, S. Rajakarunakaran, P. Pitchipoo, and R. Vimalasan, "Fuzzy based risk prioritisation in an auto LPG dispensing station," *Safety science*, vol. 101, pp. 231-247, 2018.

Appendix A

Table A1. Table of random indices

Number of criteria	2	3	4	5	6	7	8	9	10	11
RI	0	0.58	0.90	1.12	1.24	1.32	1.41	1.45	1.49	1.51

Appendix B

Table B1. Probability of occurrence Scales

frequency of occurrence	Score	percentage {%
Remote	1	< 0.01
Low	2,3	0.01 to 0.1
Moderate	4,6	0.1 to 0.5
High	7,8	0.5 to 1
very-high	9,10	>1

Table B2.non-detection scales

Non-detection	Score	non-detectability {%
Remote	1	0 to 5
Low	2	6 to 15
	3	16 to 25
	4	26-35
Moderate	5	36-45
	6	46-55
	7	56-65
High	8	66-75

	9	76-85
very-high	10	86-100

Table B3. Severity scales

Rank	Severity effect	Meaning
1	Remote	Less MTTR greater than 1 hour
2-3	Low	MTTR greater than 1 day
4-5-6	Moderate	MTTR between 1 to 4 days
7-8	High	external repair intervention
9-10	very-high	Line shut down or production loss

Appendix C

Table C1. Severity scale

Level	Severity on Personnel	Severity on Equipment	Severity on Environment	Severity on Production	Severity on management
1	No effects or personal injury	No significant effects on site equipment	No significant impact to the environment	<4 hours of downtime	No impact
2	minor effect for a person fortuitously close to the accident site	Damage to hazardous site equipment without accident synergy or non-critical safety equipment	Limited impact on the site with minimal depollution	< 1 DAY of downtime	damage or impact having no consequences on the progress of the project
3	Critical effect for a person fortuitously close to the accident site	Damage to hazardous or safety equipment on-site without general aggravation of	Normal impact requiring extensive depollution	<1 week of downtime	damage or impact having low consequences on the project progress delay or Cost overrun

		the consequences			<10 %
4	At least one victim outside the site or at least 2 victims on the site	Damage to hazardous or safety equipment, on-site with the possibility of aggravated consequences.	Serious impact to vulnerable areas	<1 month downtime	damage or impact have Serious consequences on the project progress , delay or Cost overrun >10 %
5	numerous deaths > 2 victims	Damage to hazardous or safety equipment, off-site, or on-site with the possibility of aggravated consequences.	Very-Serious impact to vulnerable areas with local repercussions	> 1 month of downtime	Significant impact calling into question the continuation of the project. , delay or cost overrun >50% regarding to the project duration or budget

Appendix D

Table D1. Rules of combination of criticality parameters

Rules	Probability	Non-detection	Severity	Criticality
1	High	Very-High	Very-High	Very-important
2	High	High	Very-High	Moderate
3	High	Very-High	High	important
4	High	High	Moderate	important
5	High	Very-High	Moderate	important
6	Very-High	Very-High	Very-High	Very-important
7	Very-High	High	High	important
8	Very-High	Moderate	Very-High	important

9	Very-High	Low	Very-High	important
10	Very-High	Remote	High	Low
11	Moderate	High	High	important
12	Moderate	Very-High	Very-High	important
13	Moderate	High	High	Moderate
14	Moderate	High	Very-High	Moderate
15	Moderate	Moderate	High	Moderate
16	Moderate	High	Moderate	Low
17	Moderate	Moderate	Moderate	Minor
18	Low	High	Moderate	Minor
19	Low	Moderate	Moderate	Minor
20	Low	Low	Moderate	Not-important
21	Low	Low	Low	Not-important
22	Low	High	High	Moderate
23	Low	Moderate	High	Minor
24	Remote	Low	Moderate	Not-important
25	Remote	Moderate	Moderate	Not-important
26	Remote	Remote	Remote	Not-important
27	Remote	Low	Low	Not-important

Appendix E

Table E1 Fuzzy AHP scales

Linguistic Variables	Scale	Fuzzy Triangular Scale
Equal importance	1	(1,1,1)
Equally to Moderately	2	(1,2,3)
Moderate importance	3	(2,3,4)
Moderately to Strongly	4	(3,4,5)
Strongly importance	5	(4,5,6)
Strongly to Very Strongly	6	(5,6,7)
Very strong importance	7	(6,7,8)
Very Strongly to Extremely	8	(7,8,9)
Extreme importance	9	(8,9,9)