



الجمهورية الجزائرية الديمقراطية الشعبية  
People's Democratic Republic of Algeria  
وزارة التعليم العالي والبحث العلمي  
Ministry of Higher Education and Scientific Research

جامعة وهران 2 محمد بن أحمد  
University of Oran 2 Mohamed Ben Ahmed  
معهد الصيانة والأمن الصناعي  
Institute of Maintenance and Industrial Safety

## Department of Industrial Safety and Environment

# THESIS

For the Requirements of a Master's Degree

**Field:** Industrial Safety and Hygiene

**Specialty:** Safety, Industrial and Environment

## Topic

**An automated Dashboard for risk management  
TERGA SKT Power plan case study**

Submitted By:

ABED Hadil & BENDJEBBAR Rihab

Before the Jury Composed of:

Full Name	Grade	Institution	Role
			Chairman
ZOUAIRI SAIM		University of Oran 2	Supervisor
			Examiner

Academic Year 2023/2024

# ***Acknowledgment***

*First of all, we would like to thank Almighty and Merciful God, who has given us the strength and patience to accomplish this modest work.*

*Secondly, we would like to express our deepest and most sincere thanks to all those who have contributed in any way to the realization of this project.*

*Our personal thanks go to Mr. Zouairi Saim, who did us the honour of supervising us, and thanks to whom we were able to complete this work.*

*Our sincere thanks go to Mr. Khaled, Mr. Zouhir and the entire HSE team, our internship sponsors at SKT, for their encouragement, support and involvement during this project.*

*We would also like to thank the members of the jury for their kindness in to evaluate our modest work.*

*We would also like to express our gratitude to all the teaching and administrative staff*

*and administrative staff of the Institute of Industrial Maintenance and Safety for their availability and attention throughout our university course.*

*We would also like to thank our parents for their contribution, support and patience.*

*Last but not least, we would like to express our sincere thanks to family members, friends and family, who have always supported and encouraged us and encouraged us throughout the completion of this thesis.*

## Dedication

*I dedicate my deepest gratitude to my dear parents who supported me throughout my studies.*

*This work is dedicated to thank you for everything you have done to provide me with a good education and support me all these long years.*

*To my dear brothers Mohamed El-Amin and Sheikho.*

*To my dear sister Samiha and her children Sohaib and Reinad.*

*To my special person...*

*Rihab...*

## Dedication

*I dedicate this project to My parents, who never failed to support us financially and morally, providing us with all our needs during our development and teaching us that the biggest task can be accomplished even if it is done step by step.*

*I dedicate this project to my uncle Houari and his wife, and my cousin Amin, who worked hard to help us accomplish this project.*

*To my dear brothers Abdennour, Nadir, and Badro*

*To my dear sister Souhir*

*To my dear friends Israa, MRM and Kheira , Ikhlas*

*To my special person...*

*Hadil...*

## Abstract

Every day, thousands of individuals succumb to accidents at work or succumb to fatal work-related illnesses, losses that are preventable with proper risk management. This project focuses on the creation, development, and implementation of an automated dashboard specifically designed for SKT TERGA. The dashboard provides a clear visual representation of risk levels, helping to prioritize risks based on their potential impact and likelihood. By highlighting the most critical risks, this visualization supports informed decision-making and facilitates the communication of risk information to stakeholders. Furthermore, it enables real-time monitoring, allowing for continuous assessment and updating of risks. The project employs the Failure Modes, Effects, and Criticality Analysis (FMECA) method to systematically assess and evaluate the risks, ensuring a thorough and structured approach to risk management. This tool aims to significantly enhance workplace safety and health by identifying and mitigating potential hazards before they lead to severe consequences.

**Keywords:** Risk Management, Risk Assessment, Automated Dashboard, Critical Risks, Failure Modes, Effects, and Criticality Analysis (FMECA).

## المخلص

يخسر الآلاف من الأفراد حياتهم يوميًا نتيجة لحوادث العمل أو الأمراض المرتبطة بالعمل، وهي خسائر يمكن تجنبها بإدارة المخاطر بشكل صحيح. يركز هذا المشروع على إنشاء وتطوير وتنفيذ لوحة تحكم آلية مصممة خصيصًا لشركة SKT TERGA. توفر لوحة التحكم هذه تمثيلًا بصريًا واضحًا لمستويات المخاطر، مما يساعد على تحديد الأولويات استنادًا إلى تأثيرها المحتمل واحتمالية حدوثها. من خلال تسليط الضوء على المخاطر الأكثر أهمية، تدعم هذه الأداة اتخاذ القرارات المستنيرة وتسهل عملية التواصل مع أصحاب المصلحة بشأن المعلومات المتعلقة بالمخاطر. علاوة على ذلك، تُمكن من المراقبة في الوقت الفعلي، مما يسمح بالتقييم المستمر وتحديث المخاطر. يستخدم المشروع طريقة تحليل حالات الفشل وأثارها والحساسية (FMECA) لتقييم المخاطر بشكل منهجي، مما يضمن نهجًا شاملاً ومنظمًا لإدارة المخاطر. يهدف هذا الأداة إلى تعزيز سلامة وصحة مكان العمل بشكل كبير من خلال تحديد وتخفيف المخاطر المحتملة قبل أن تؤدي إلى عواقب وخيمة.

**الكلمات المفتاحية:** إدارة المخاطر، تقييم المخاطر، لوحة تحكم آلية، المخاطر الحرجة، تحليل أنماط الفشل وتأثيراته ومؤثراته الحرجي (FMECA).

## List of Abbreviations

- BP : Pression de base.
- D : Détectabilité.
- EGA : Electricité et gaz d'Algérie.
- EPC : Ingénierie, approvisionnement et construction.
- EPP : Protection des équipements de la personne.
- ETA : Analyse de l'arbre des événements.
- F : Fréquence d'apparition.
- FMEA : Modes de défaillance et analyse des effets.
- FEMECA : Analyse des modes de défaillance, de leurs effets et de leur criticité.
- FTA : Analyse d'arbre de défaillances.
- GEAT : Turbines General Electric Algérie.
- GFCI : interrupteurs de circuit de fuite à la terre.
- HAZOP : Etude de danger et d'opérabilité.
- HIRA : identification des dangers et évaluation des risques.
- VIH : Virus de l'immunodéficience humaine.
- HP : Haute Pression.
- ISO : Organisation internationale de normalisation.
- MP : Pression moyenne.
- MSF : Flash multi-étapes.
- PRA : Analyse préliminaire des risques.
- R : Risque.
- RPN : Numéro de priorité du risque.
- FDS : Fiche de données de sécurité.
- S : Gravité.
- SKE : Shariket Kahraba El Djazaïr.
- SKT : Shariket Kahraba Terga.
- TG : Turbine à gaz.
- TS : Turbine à vapeur.

## List of Figures

Figure 1.1: The general organizational chart of Sonelgaz.....	7
Figure 1.2: 3D view of the TERGA power plant.....	8
Figure 1.3: The geography of the TERGA power plant.....	9
Figure 1.4: Diagram of the tree line.....	10
Figure 1.5: The components of the gas turbine.....	10
Figure 1.6: Alternator.....	11
Figure 1.7: Steam turbine.....	12
Figure 1.8: Recovery boiler.....	13
Figure 2.1: Risk Management Process.....	24
Figure 2.2: Typology of risk analysis methods.....	29
Figure 2.3: Typology of types of analysis method.....	29
Figure 2.4: Risk analysis methods.....	30
Figure 2.6: Failure Tree Analysis.....	34
Figure 2.7: Bow Tie method.....	36
Figure.2.5: The FMECA approach.....	39
Figure 3.1: Work at height.....	42
Figure 3.2: Lifting operation.....	44
Figure 3.3: Confined space.....	45
Figure 3.4: Proper Lifting Techniques Diagram.....	47
Figure 3.5: Welding.....	49
Figure 3.6: System deluge.....	51
Figure 3.7: Fire extinguishers.....	51
Figure 3.8: CO2 fire extinguishing.....	51
Figure 3.9: Argonite system 11SGK31.....	52
Figure 3.10: Detection system.....	52
Figure 3.11: System sprinkler. ....	53
Figure 3.12: Various Types of Electrical PPE.....	54
Figure 3.13: Cutation risk of explosion.....	55
Figure 3.14: Chemical product.....	56
Figure 3.15: Functional analysis of electrical installation.....	57
Figure 3.16: Risk Priority Number (RPN).....	58
Figure 3.17: Criticality before FMECA. ....	71

Figure 3.18: Criticality after FMECA. ....	72
Figure 3.19: Histogram comparing criticality statistics graph before and after the implementation FMECA.....	79
Figure 4.1: Risk type.....	80
Figure 4.2: Risk levels 1.....	80
Figure 4.3: Risk levels 2.....	81
Figure 4.4: Severity type.....	82
Figure 4.5: likelihood type.....	83



## List of Tables

Table 2.1: Classification of industrial risks.....	23
Table 2.2: risk acceptance and evaluation criteria.....	27
Table 3.1: The four basic FMECA questions.....	57
Table 3.1: Criticality assessment.....	57
Table 3.2: Assessment of non-detection.....	58
Table 3.3: Assessment of Frequency.....	58
Table 3.4: Assessment of Severity.....	59
Table 3.5: Criticality assessment.....	59
Table 3.6: Failure Mode Effects and Criticality Analysis.....	61
Table 3.7: Failure Mode Effects and Criticality Analysis.....	62
Table 3.8: Failure Mode Effects and Criticality Analysis.....	63
Table 3.9: Failure Mode Effects and Criticality Analysis.....	64
Table 3.10: Failure Mode Effects and Criticality Analysis.....	65
Table 3.11: Failure Mode Effects and Criticality Analysis.....	66
Table 3.12: Failure Mode Effects and Criticality Analysis.....	67
Table 3.13: Failure Mode Effects and Criticality Analysis.....	68
Table 3.14: Results of application of FMECA before application.....	69
Table 3.15: Results of application of FMECA after application.....	70
Table 3.16: Risk assessment.....	79

## Table of contents

Chapter 1 .....	3
I.Introduction.....	4
II. The Sonelgez group .....	4
II.1.Presentation:.....	4
II.2.The objectives of Sonelgaz: .....	4
II.3.Historical development: .....	4
II.4.Subsidiaries: .....	6
II.5.The Shariket Kahraaba El Djazair (SKE) Company .....	7
III. Presentation of the SKT power plant.....	7
III.1.Location of plant:.....	8
III.3.Power to the plant .....	9
III.4.PRINCIPLE OF OPERATION OF THE CENTRAL .....	10
III.4.1.the production of electrical energy.....	10
III.4.2.General view of components and major systems:.....	10
IV. Conclusion:.....	18
Chapter 2 .....	19
I. Introduction.....	20
II. Base Definitions .....	20
II.1. Hazard.....	20
II.2. Risk.....	21
II.3. Harm .....	21
II.4. Accident.....	21
II.5. Incident .....	21
II.6. Safety.....	21
II.7. Severity .....	21
II.8. Likelihood.....	21
II.9. Exposure .....	22
II.10. Damage .....	22
III. Industrial risk definition .....	22
III.1. Classification of industrial risks .....	22
IV. Risk Management.....	23
IV.1. Risk management definition .....	23

IV.2.	Risk assessment .....	23
IV.3.	Principles of risk management .....	24
V.	Risk Management Process .....	24
V.1.	Risk identification: .....	25
V.2.	Risk Analysis:.....	26
V.3.	Risk evaluation .....	26
V.4.	Risk treatment.....	27
V.5.	Risk communication and consultation.....	27
V.6.	Risk monitoring and review .....	28
VI.	Risk analysis tools .....	28
VI.1.	Classification of risk analysis methods .....	28
VI.2.	The principal risk analysis tools .....	30
VI.2.1.	Preliminary risk analysis (PRA): .....	30
VI.2.2.	HAZOP (hazard and operability study) .....	31
VI.2.3.	Failure Tree Analysis .....	33
VI.2.4.	Event Tree Analysis .....	34
VI.2.5.	The Bow Tie Method .....	35
VI.2.6.	FMCEA.....	36
VI.2.6.1.	History and field of application .....	36
VI.2.6.2.	Definition.....	36
VI.2.6.3.	Principle.....	37
VI.2.6.4.	Purpose of the FMECA .....	38
VI.2.6.5.	FMECA Objectives .....	38
VI.2.6.6.	Types of FMECA .....	38
VI.2.6.7.	The FMEA approach .....	38
VI.2.6.8.	Limitations and advantages .....	40
VII.	Conclusion.....	40
I.	Introduction.....	42
II.	Risk assessment In the power plant.....	42
II.1.	Work at height .....	42
II.2.	Lifting .....	43
II.3.	Confined spaces .....	45
II.4.	Manual handling .....	46

II.5. Mechanical handling.....	48
II.6. Hot work.....	49
III. Major risks.....	50
III.1. Fire Risk.....	50
III.2. Electrical Risk.....	53
III.3. Explosion risk.....	54
III.4. Chemical Risk.....	55
IV. FMECA method.....	57
IV.1. System studied : .....	57
IV.2. Functional analysis of electrical installation:.....	57
IV.3. Criteria for choosing the FMECA method.....	58
V. Application of FMECA.....	61
Chapter4 .....	75
I. Introduction.....	76
II. Risk assessment.....	76
III. Dashboard: .....	80
VI. Conclusion.....	84
BIBLIOGRAPHY .....	86

### General introduction

Significant progress has been made over the last half century in the field of occupational health and safety prevention, but it is only in the last ten years or so that public authorities, social partners and occupational health and safety organizations have been particularly focused on the concept of risk prevention in private companies and public institutions.

Work plays an important role in our lives, with most workers spending 08 hours or more in the workplace, so the work environment should be healthy and safe.

Unfortunately, this is not the case for many workers who are exposed to a number of hazards that threaten their health (dust, gas, noise, vibrations, extreme temperatures, etc.) The industrial world has witnessed some catastrophic accidents that have had a significant impact on people (physical, social and psychological), the environment (air pollution, water and soil contamination), plant and equipment.

Failure Modes, Effects and Criticality Analysis (FMEA) plays an essential role in risk management. This may include design modifications, process changes, maintenance improvements, additional staff training, and continuous improvement of risk management. It allows for the identification of potential failures in each component or process in the system as well as criticality determination to prioritize the most important risks. This helps to anticipate issues before they occur.

A risk management dashboard is an essential tool for companies seeking to identify, assess and manage the risks they face. It enables managers to proactively view and monitor risks, so they can make informed decisions to mitigate potential negative impacts.

The Risk Management Dashboard provides an overview of the risks to which the organization is exposed, highlighting critical areas that require special attention. It also allows risks to be prioritized according to their likelihood and impact, helping decision makers to effectively allocate resources to mitigate these risks.

In addition, the risk management dashboard allows monitoring risk developments in real-time and detecting emerging trends, enabling the company to respond quickly and take preventive action to minimize potential losses as it provides a visual representation of key risk metrics and indicators, helping stakeholders gain a clearer view to make informed decisions.

The objective of a risk management dashboard study using FMEA (Failure Modes, Effects and Criticality Analysis) is to provide a clear and concise overview of information important for risk management decision-making. The main objectives of this study are as follows:

**Data visualization:** The dashboard makes it quick and easy to visualize data from FMECA, such as identified failure modes, their criticality, and ongoing corrective actions. This makes it easier to understand and analyze complex information.

**Real-time monitoring:** This enables real-time monitoring of risk development and implementation of corrective actions. This helps to quickly identify emerging issues and respond proactively.

**Prioritize actions:** By clearly displaying the most critical risks and priorities identified by FMECA, the dashboard helps focus efforts on the most pressing issues and optimally allocate resources.

**Effective communication:** A well-designed dashboard facilitates the communication of FMECA results to different levels of the organization, including management, operational

teams, and external stakeholders. This ensures a common understanding of the issues at hand and the actions to be taken.

**Continuous improvement:** By centralizing data and providing analysis tools, the dashboard makes it possible to monitor the effectiveness of corrective actions and identify areas for further improvement. This encourages a dynamic and iterative approach to risk management.

**Decision support:** By providing key information in a clear and accessible manner, the dashboard supports strategic and operational decision-making. This enables managers to make informed decisions based on reliable data.

In short, the purpose of our work is to assess risk with a tool and make better decisions by having a comprehensive visualization of critical situations that lead to undesirable situations. To achieve this, we were able to design a dashboard using Python programming, and explore all the data collected from the company, which can be useful for engineers who process a huge amount of written data to make decisions, thus facilitating visibility to make the decision-making process easy and short, while fostering a culture of continuous improvement within the organization.

Therefore, we conducted a survey on the combined cycle power plant in Terga, which involves many hazards, from which we selected electrical hazards to apply FMECA method and design a control panel using Python programming by collecting all the unstructured information present in the company.

### **Organization of the dissertation:**

Our thesis consists of two parts, a theoretical part and a practical part, divided into four chapters:

- The first chapter contains the detailed presentation of the combined cycle power plant SKT.
- The second chapter contains basic concepts about risks, risk management and also talks about risk analysis methods.
- The third chapter contains
  - The risk assessment in the SKT central.
  - Application of the method for analyzing failure modes and their criticality.
- In the final chapter we design the automated dashboard for SKT using Python programming and insert all the data collected from the company.

Finally, a general conclusion outlining the findings of this research.



---

# CHAPTER 01

## **PRESENTATION OF THE SKT POWER PLANT**

---



## I. Introduction

Today electrical energy is omnipresent in developed countries from different energy sources (hydraulic, thermal, nuclear, etc ....). The electricity is an energy factor used for many domestic or industrial uses. The principle of the production of electrical energy in different center electrical is to transform the mechanical energy to an electrical energy (hydraulic a electric, thermal, electric....).

Sonelgaz is the historical operator in the field of electricity and gas supply in Algeria. Thanks to the adoption of the law on electricity and gas distribution by pipelines on May 2, 2011, Sonelgaz has gone from a vertically integrated company to a holding company that manages a multi-company, multi-business industrial group.

Today, the Sonelgaz Group consists of 16 companies directly managed by the holding company, 18 companies in partnership with group entities and 10 companies in partnership with third parties.

The SKT power plant has played a very important role in the production of electricity to cover a large part of Algeria's electricity needs.

In this chapter we will present the Sonelgaz group and the SKT electricity plant and their operating principles.

## II. The Sonelgez group

### II.1.Presentation:

Sonelgaz (Algerian Electricity and Gas Company) is a company responsible for the production, transmission and distribution of electricity and gas in Algeria. It was created on July 28, 1969, replacing the previous entity Electricity and gas of Algeria (EGA), and it was given a monopoly on the distribution and sale of natural gas in the country, the same applies to the production, distribution, import, export of electricity.

Over the years, it has become a leading energy group recognized on the African and Mediterranean continent. For more than fifty years, it played a key role in the economic and social development of Algeria, which earned it the nickname “Jewel of the Republic”.

Sonelgaz is present throughout the national territory, even in the most remote areas with an electricity penetration rate of more than 99% and gas penetration of more than 60%, the highest in the world. This company has contributed to improving the quality of life of Algerians by allowing them to resolutely enter the modern world.

### II.2.The objectives of Sonelgaz:

- Strengthen and increase its presence in the sector (electricity and gas in Algeria).
- Conquer nuclear power and renewable energy.
- International development and diversification.
- Participation in the development of the country.

### II.3.Historical development:

#### 1946: Creation of EGA

At the beginning of the 20th Century, the electricity sector was made up of concessions in the hands of colonial companies. The adoption of law N 46-628 of April 8, 1946 in mainland France, establishing the nationalization of electricity and gas activities, was extended to



Algeria by the nationalization of private electricity and gas companies existing at the time. , establishing the creation of EGA (Electricity and Gas of Algeria) by decree No. 47-1002 of June 5, 1947.

### **1969: Dissolution of EGA and Creation of Sonelgaz**

Breaking with the colonial heritage and in order to respond to political and economic choices, the year 1969 marked the dissolution of EGA and its replacement by the creation of SONELGAZ (National Electricity and Gas Company), by order No. 69-59 of July 28, 1969. The new company is entrusted with the monopoly of Production, Transport, Distribution, import and export of electricity, as well as that of the distribution and sale of natural gas in the country.

### **1983: The turning point of the first restructuring**

In 1983, fourteen years after its birth, Sonelgaz carried out a first restructuring. It will give rise to five subsidiaries dedicated to specialized work and a manufacturing entity: KAHRIF (rural electrification), KAHRAKIB (electrical infrastructure and installations), KANAGHAZ (construction of gas networks), INERGA (Civil Engineering), ETTERKIB (industrial assembly), and AMC (manufacture of meters and measuring and control devices).

### **1995: Sonelgaz becomes EPIC**

By executive decree No. 95-280 of September 17, 1995, Sonelgaz became a Public Establishment of an Industrial and Commercial Character (EPIC). Placed under the supervision of the Ministry of Energy and Mines. Endowed with legal personality while enjoying financial autonomy, it is governed by the rules of public law in its relations with the State and deemed commercial in its relations with third parties. The same decree attributes the public service mission to Sonelgaz.

### **2002: Commerciality at the heart of the new strategy**

By Presidential Decree No. 02-195 of June 1, 2002, Sonelgaz becomes the Algerian Electricity and Gas Company, a Joint Stock Company (SPA). It is governed by the provisions of the law relating to electricity and gas distribution by pipeline and by the provisions of the commercial code. This status gives it the possibility of expanding its activities to other areas in the energy sector and also of operating internationally.

### **2004: The Sonelgaz Industrial Group was born**

In 2004, Sonelgaz rose to the top of the list of national investors and established itself as a key player in national development with the prospect of becoming a catalyst for national and foreign investments in the national energy sector. Consequently, it adopts an industrial group organization through the transformation into subsidiaries of its entities in charge of basic businesses: - Electricity Production (SPE), Electricity Transport (GRTE Electrical System Operation (OS), Gas Transport (GRTG), - Distribution of Electricity and Gas from Algiers (SDA), the Center (SDC), the East (SDE) and finally the West (SDO).

### **2009: Completion of restructuring, renewal**

Between 2007 and 2009, always with a view to enhancing its performance, Sonelgaz adopted a new organization. This results in a Group with 33 subsidiaries and 6 directly-held companies. With the opening of the Electricity and Gas Training Institute (IFEG) in 2007, as well as the creation of engineering, information systems and real estate management companies (CEEG, ELIT & SOPIEG) and the integration of the Rouïba Eclairage Company

in 2009, it completed its transformation into a holding company determined to develop and strengthen its electrical and gas infrastructure.

### **2011 The Holding Company**

On 02 May 2011, the statutes of Sonelgaz, adopted in 2002, were amended by the Council of Ministers. They thus become compliant with the provisions of Law No. 02 - 01 of 5 February 2002 on electricity and gas distribution by pipelines. Spa is now organized as a «HOLDING COMPANY», without the creation of a new legal entity. The Sonelgaz Holding and its subsidiaries then form a group called «Sonelgaz Group».

### **2012 New growth, new course: renewable energies**

Renewable energies, including solar photovoltaic energy, have been developing in Algeria for two decades. Sonelgaz, a pioneer in this field, has already electrified 18 villages far from the South, between 1998 and 2001, by introducing the solar sector.

### **2014/2015: Partnership at the heart of development**

In 2014, in partnership with General Electric, creation of a company called GEAT (General Electric Algeria Turbines), responsible for the construction and operation of an industrial complex located in Ain Yagout (wilaya of Batna) intended to produce TG and TS. Partnership with Hyundai and Daewoo and creation of the company called HYENCO responsible for providing EPC (Engineering, Procurement and Construction) services for industrial energy works.

### **2017: A new Distribution organization**

2017 was the year of a new organization to further improve the effectiveness of the Group's companies and make them more efficient through the pooling of their own experiences and the harmonization of their know-how. Thus, the distribution business now comes under a single entity called Society Algerian de Distribution de Electricity and Gas (SDC). The SDC is the result of the merger-absorption by the latter of the distribution companies SDE, SDO and SDA...

### **2020-2021: A new strategy for new horizons**

The new strategic plan, called Sonelgaz 2035, has ambitions for the Group. Indeed, the strategy refocuses Sonelgaz's missions on its role as an energy company whose main purpose is to provide reliable and responsible energy, ensure a quality public service and contribute to the well-being of customers and sustainable development.[1]

## **II.4.Subsidiaries:**



Figure 1.1: The general organizational chart of Sonelgaz.[2]

### II.5. The Shariket Kahraba El Djazair (SKE) Company

It is a merger and Absorption Company and staff transfer agreements of the subsidiary companies of Sonelgaz SK Terga, SK Koudiat Eddarouch and SK Berouaghia by the company SK Skikda 51% owned Sonelgaz and 49% Sonatrach was signed 01 October 2020 in Algiers to allow a better reorganization of the electricity production activity and a reduction in light management costs of the current financial crisis.

### III. Presentation of the SKT power plant

The combined cycle power plant Terraga in the Wilaya of Ain T'émouchent was put into operation in June 2012.

With a capacity of 1200 megawatts, the plant in question was intended to cover a large part of the electricity needs of the region of Oranie as it played an important role in the «interconnection of national electricity networks».

The shareholders of this plant are the national groups Sonelgaz (51%) and Sonatrach (49%).

It operates on natural gas and diesel (emergency) while its management is entrusted to the joint stock company (SPA) «Shariket Kahraba Terga» (SKT).

The Terga combined cycle power plant was built by the consortium led by Alstom and comprising the Egyptian company Orascom Construction Industry for the civil engineering and construction part, for an amount of two billion dollars.

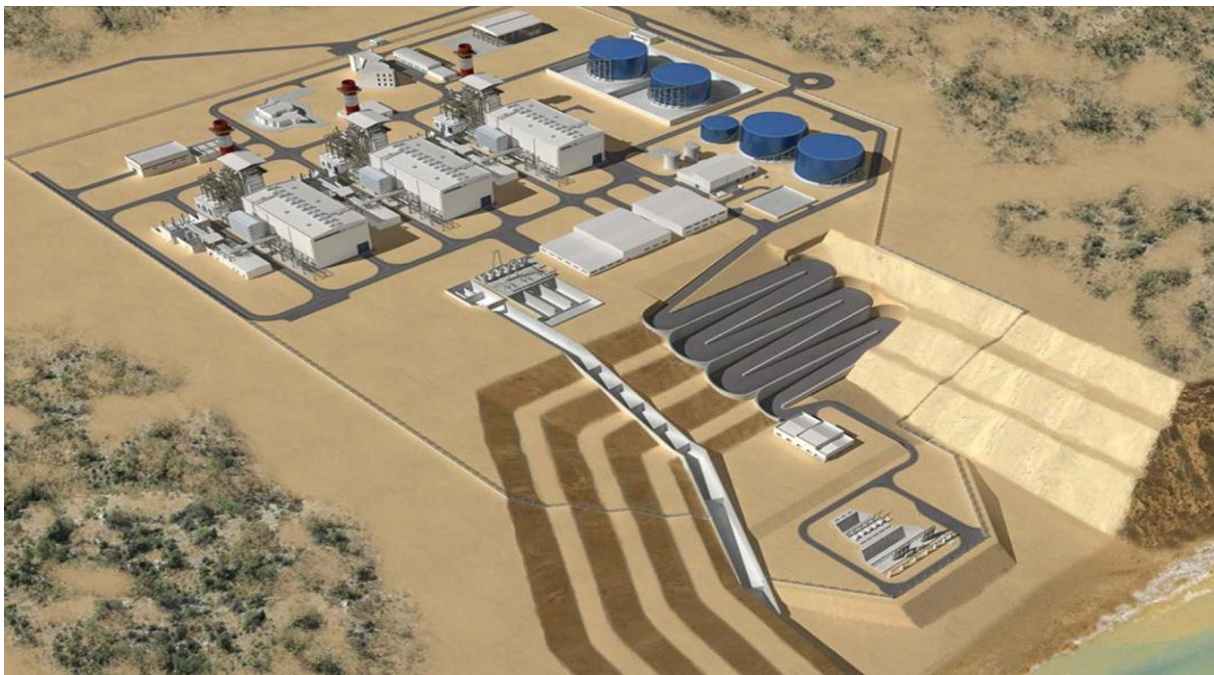

**Figure 1.2:3D view of the TERGA power plant.[3]**

### **III.1.Location of plant:**

The SKT power plant is located in the west of Algeria, in the municipality of OULED BOUDJAMAA 25 Km in Ain Témouchent.



**Figure 1.3: The geography of the TERGA power plant.[3]**

### III.2.Objective of the power plant

The main role of this power plant is to produce electrical energy from the combustion of natural gas, it is loaded with national framework grants to supply with other parallel power plants an interconnected network that goes from east to west through the center.

The operation of this network is ensured by the dispatching, located at the level of ALGIERS the load with a frequency of 50 HZ.

The TERGA power plant participates in this network with a power of (1200MW), operating (3GROUPS).

The combined cycle power plant «3 x 400 MW » consists of three single-shaft units.

Each unit consists of:

- A gas turbine (TG) ALSTOM type GT 26 equipped with a system of sequential combustion with lean pre-mixing and low NOx emissions.
- A water / steam cycle with three pressure levels and reheating with recovery boiler.
- A steam turbine (TS) two bodies with three pressure levels and resurfacing.
- A hydrogen-cooled alternator, common to both turbines.

### III.3.Power to the plant

The power plant is supplied in three parts: gas, electricity and water of sea.

#### ✓ In gas:

Methane CH<sub>4</sub> brought back from HASSI RMEL transiting by different pumping until Med gas then will supply the power plant.

#### ✓ In electricity:

Self-powered, it takes its energy from these groups, if they are stationary, the power plant receives its energy requirement from the grid through these Main transformers.

#### ✓ Sea water supply:

Seawater by a water treatment plant produces desalinated water, then by a Demineralization station.

### III.4.PRINCIPLE OF OPERATION OF THE CENTRAL

#### III.4.1.the production of electrical energy

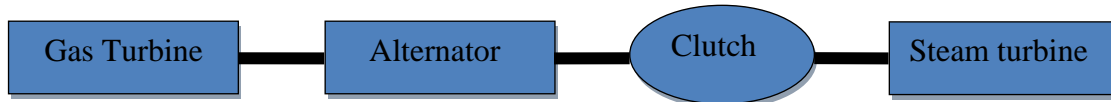

**Figure 1.4: Diagram of the tree line.**

The gas turbine compresses the ambient air which ignites in the presence of natural gas pressurized. As soon as the fuel/air mixture is consumed, the hot gases expand through a turbine, which is connected to an alternator for the electricity production.

The turbine exhaust is connected to the HRSG recovery boiler for the steam-making.

The steam is sent to a turbo-alternator unit to increase production of electricity.

#### III.4.2.General view of components and major systems:

##### III.4.2.1.Gas turbine:

Alstoms GT26 gas turbine consists of a rotor consisting of a « high pressure » turbine stage, 4 « low pressure » turbine stages, 22 compressor stages, and two annular combustion chambers (the EV and SEV burners), applying the sequential combustion principle.

The gas turbine compresses the ambient air which ignites in the presence of natural gas Pressurized. As soon as the fuel/air mixture is consumed, the hot gases expand through a turbine, which is connected to an alternator for the production of electricity. The turbine exhaust is connected to the HRSG recovery boiler for the manufacture of steam. The steam is sent to a turbo-alternator unit to increase the production of electricity.

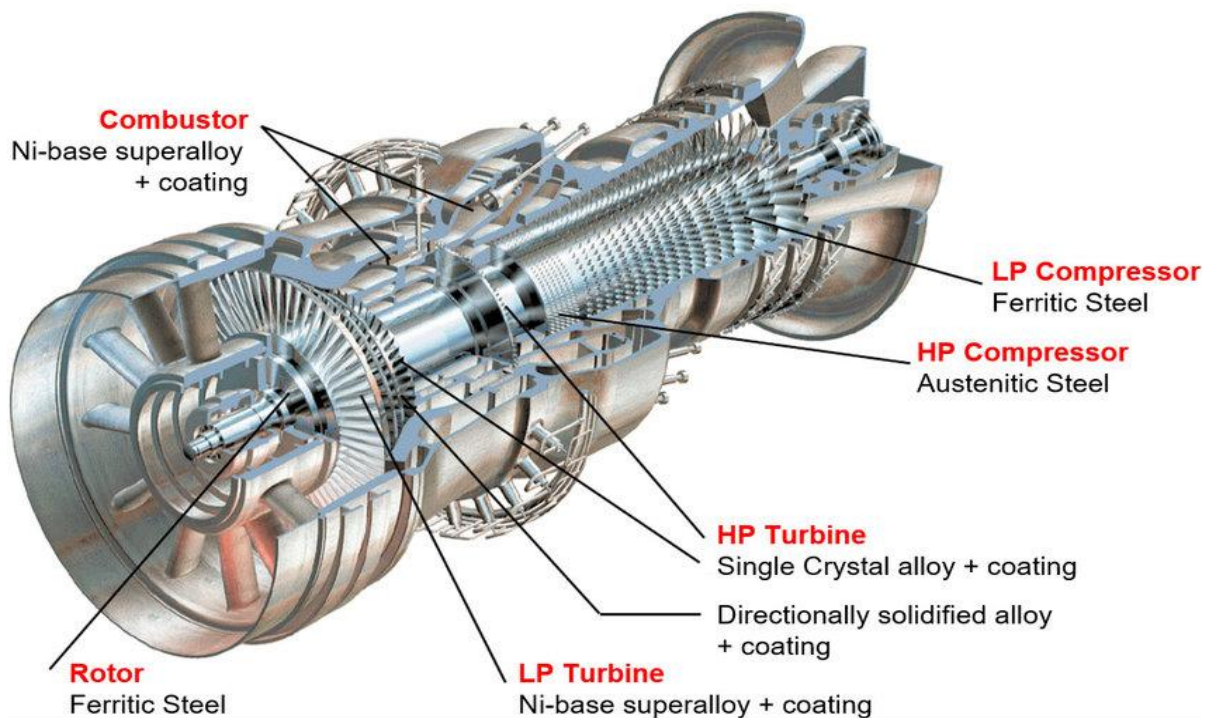

**Figure 1.5: The components of the gas turbine.[4]**

### III.4.2.2. Alternator

The Alstom alternator (type 50WT21H-120) is driven by both the gas turbine and the steam turbine.

The power is produced at a voltage of 20kV. The alternator, with three phases and two asynchronous poles, is cooled with hydrogen.

The hydrogen is then cooled in water exchangers located in the chamber of the alternator.



**Figure 1.6: Alternator.**[3]

### III.4.2.3. Synchronous auto-switchable clutch between the TS and the Alternator

The clutch makes it possible to connect the TS to the alternator, while the latter is already driven by the TG:

- The clutch engages automatically as soon as the torque of the TS becomes positive; that is, as soon as the speed of the TS tends to exceed that of the alternator.
- The clutch disengages automatically as soon as the torque of the TS becomes negative; that is to say as soon as the speed of the TS tends to pass below that of the alternator.

No regulation system is necessary for the clutch.

### III.4.2.4. Steam turbine

The Alstom steam turbine, type DKYZZ2-1N41BA, has two bodies, three pressures, and a resurfacing.

The first body is the high pressure (HP) stage and the second body of the turbine consists of the medium pressure (MP) and low pressure (BP) stages. The MP/BP body is dual flow. The two rotors of the HP and MP/BP bodies are linked together by a rigid coupling. The HP rotor is also connected to the clutch by a rigid coupling.

The steam is admitted in the HP and MP bodies through the intake organs including the shut-off and control valves. The HP inlet is achieved by a frame in which the valves are mounted in series, and the MP inlet uses two frames where the shut-off valves and control valves are fully integrated into the same spherical body clamped to the MP outer body.

The HP live steam, regulated by a shut-off valve and a control valve, enters the HP body and relaxes to the steam pressure to be heated again. The steam to be reheated is mixed with the PM steam produced by the recovery boiler before being reheated in the recovery boiler.

BP steam enters the turbine through a shut-off valve and a control valve. The steam from the BP exhaust body of the turbine is sent to the condenser.

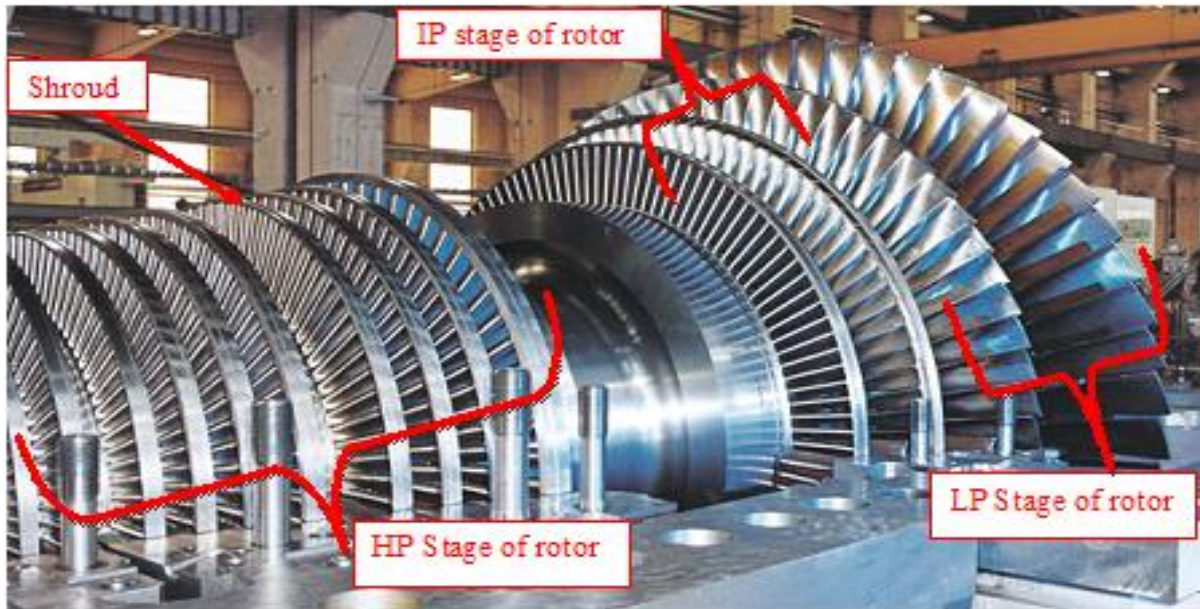

Figure 1.7: Steam turbine.[5]

### III.4.2.5.Recovery boiler and TG air refrigerants

#### III.4.2.5.1.Recovery boiler

The recovery boiler is of the horizontal type. The three pressure levels BP, MP and HP work in natural circulation mode. Each exhaust TG is directed to the associated boiler (boiler operation of recovery). The HP/MP feed pumps feed the recovery boiler, the BP feed water is extracted downstream of the second row MP/BP economizer. The feed water is warmed up in the respective economizers. Each level of HP, MP and BP balloon is controlled by a control valve. The saturated steam is produced in HP, MP and BP evaporators.

The HP steam is led to the multi-stage HP super heater, the MP steam to the MP super heater and subsequently to the resurfacing, the BP steam is superheated too. At the output of the recovery boiler, the HP and MP vapors are desuperheated with the food water extracted from the HP and MP economizers respectively.

Water extracted from the HP economizer feeds the TG air refrigerants and in order to adjust the temperature of the food water upstream of the refrigerants, within a certain range, there is the possibility of adjusting the temperature with an extraction upstream of the first HP economizer, if necessary (manual valve of control adjusted during commissioning).

An extraction downstream of the economizer MP supplies, in water, a gas pre-driver in order to increase the inlet gas temperature TG from about 15 °C to 150°C., which improves the efficiency of the combined cycle. The water coming out of the gas pre-driver is sent to the food tarpaulin. The boiler purge tank collects the purges from the recovery boiler and TG air



refrigerants the external purge recovery tank turbine collects the purges of the steam to be reheated BP, the superheated steam and the steam reheated.

After separation, the steam goes to the food cover (and therefore kept in the water/ steam cycle) and the condensates are returned to the industrial water recovery tank.

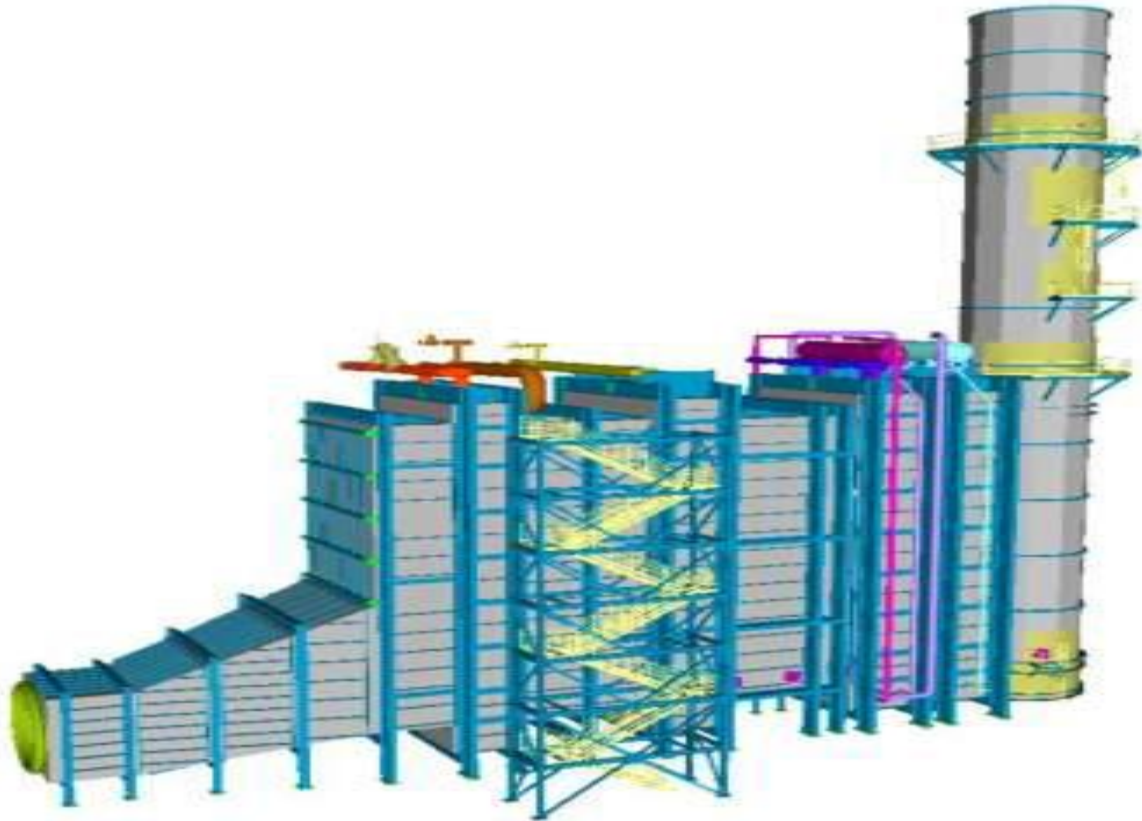

**Figure 1.8: Recovery boiler.**

#### **III.4.2.5.2: TG air refrigerant**

An HP refrigerant and a BP refrigerant are required for the cooling of the TG air. The refrigerants are helicon type heat exchangers. They are supplied with HP water and the supplied steam is sent into the HP steam system of the recovery boiler.

#### **III.4.2.6. Water / Steam Cycle**

##### **III.4.2.6.1. Condenser**

The installation is of axial design cooled with seawater. The condenser is consisting of two double-pass beams. In order to operate the condenser with a only half condenser, the water boxes are divided. Due to the increase in the pressure at the exhaust of the TS, the power produced is in this case reduced. The non-condensable gases on the steam side are extracted from each bundle of tube at the coldest place, the partial vapor pressure is lower there. The steam condensed is sent to the condenser well, which thus serves as a capacity of storage. The blow-out balloon of the purges is connected to the condenser and collects the internal purges

of the steam turbine. The vapor phase is returned to the condenser and the condensates are returned to the condenser well.

#### **III.4.2.6.2. Condensate extraction pumps:**

The main extraction pumps are of vertical type. In normal operation, one pump is in operation. The second remains in emergency.

The emergency pump is switched on automatically if the pump in operation is faulty or if the bypass of the steam turbine is in high load operation

#### **III.4.2.6.3. Condenser vacuum system (Steam Side)**

The vacuum system consists of a starting ejector and of two holding ejectors.

The ejectors evacuate the steam on the condenser side during start-up and extract non-condensable gases during the operation of refrigerants or air from the condenser.

The motive steam for the ejectors is taken from the steam line at reheat and the extracted incondensable are sent to the atmosphere.

An expansion valve regulates the pressure of the steam at the inlet of the ejector of start and a second control valve reduces the steam pressure to the entrance to the service ejectors.

#### **III.4.2.6.4. Food tarpaulin / Degasser**

A food tarpaulin equipped with a degasser stores the food water for the recovery boiler, preheats and degasses the extraction water.

In normal gas operation, the food water is preheated by the food water preheating system. In operation at low charge or diesel oil, preheating uses the steam to be reheated.

#### **III.4.2.6.5. Food pumps**

The two HP horizontal type food pumps equipped with extraction for food water MP/BP are multi-stage, and have suction filters and minimum flow valves. In normal operation, a pump is in operation. The second remains in emergency. The emergency pump is switched on automatically in case of failure of the pump in service.

#### **III.4.2.6.6. Food water preheating pumps**

The food water is pumped by two recirculation pumps and passes in the preheating exchanger of the recovery boiler and then returns in the food tarpaulin to heat the latter to the temperature requested.

Each recirculation pump is provided with a minimum flow device to the tarpaulin. The reheat steam, if necessary, is taken on the line of steam to be reheated. The pressure regulating valve of this power supply makes it possible to regulate the pressure of the degasser and consequently the temperature of food water. This method of regulating the temperature of the tarpaulin food is widespread, reliable, and effective in a wide range of temperature.

#### **III.4.2.6.7. TS steam bypass systems**

When the turbine cannot accept all of the HP steam, the HP bypass directs the superheated steam to the MP circuit (steam to be reheated) via an expansion and desuperheating valve supplied by a withdrawal downstream of the food water pumps. This allows a cooling of the HP resuperheaters from the recovery boiler. The MP and BP bypasses direct the steam directly to the condenser through diffusers, the steam being desuperheated by the extraction water.

These bypasses allow independent operation of the boiler when the turbine is tripping or not available. They also allow the steam conditioning for TV start-up. The power plant can start without auxiliary steam available for power supply the sealing system, the reheated steam circuit is also equipped of regulating vent valves discharging the steam directly to the atmosphere at the time of start-up. Each steam bypass is capable of treating 100% of the nominal flow rate of the live steam at 100% of the nominal pressure of the live steam.

#### **III.4.2.6.8.Steam turbine sealing system**

The steam sealing system of the TS prevents the air from being sucked into the vacuum parts of the turbine, and the steam from the turbine to escape. The side's pressure and suction of the steam sealing system are connected for the three sections of the steam turbine.

#### **III.4.2.6.9.Recovery balloon for atmospheric purges**

The recovery balloon of the purges to the atmosphere collects the external purges to the steam turbine. After separation the steam is sent to the atmosphere and the condensate is returned to the effluent treatment system.

#### **III.4.2.7.Desalinated water production**

The water treatment plant produces desalinated water. This station consists of a multistage flash type desalination unit (MSF for Multi Stage Flash). The produced water is collected in the desalinated water storage tanks. The installation comprises 2 desalination units common to the three units of the power plant operating according to the principle of distillation by successive expansion and producing 960 m<sup>3</sup> / day of desalinated water each. The desalinated water produced will be stored in two atmospheric pressure tanks with a capacity of 17,500 m<sup>3</sup> each.

#### **III.4.2.8.Hydrogen production station**

The installation is common to the three units and includes:

- An electrolyzed.
- A washing and cooling group.
- A gas meter.
- Two compressors with dryers.
- Piping, pumps and accessories.
- Electrical equipment.
- Control equipment command.

The electrolyzed is equipped with:

- A block of cells divided into two chambers to separate the H<sub>2</sub> produced at the cathode from the O<sub>2</sub> released at the anode.
- Of gas separators, one for the H<sub>2</sub> and the other for the O<sub>2</sub> for the separation of the gas from the electrolyte.

A cooling system is provided in order to recover the saturated steam containing caustic potash, entrained with the gases, the condensates generated returning to the electrolyzed.

A washing system is necessary to remove the traces of potash contained in the gas. A gas meter is used for the storage of hydrogen and serves as a buffer between the electrolyzed and the compression installation.

### **III.4.2.9.The system of quality control and chemical injection**

#### **III.4.2.9.1.Water-steam cycle sampling station**

There is a quality control system for water-steam cycle. To ensure a long operating life of the recovery boiler it is necessary to ensure a good control of the physico-chemical parameters.

In this case the manufacturer has installed a system to take samples continuously and make instantaneous analyses of the different locations of the water-steam cycle. The quality control system is the sampling station equipped with different sample and automatic analyzers as follows:

- Silica analyzer.
- Sodium analyzer.
- Oxygen analyzer.
- Conductivity analyzer.

#### **III.4.2.10.Chemical post-dosing**

In order to minimize the phenomenon of corrosion for our high pressure boiler the manufacturer has installed the chemical dosing station contains the following equipment:

- A carbo-hydrazine injection system to remove oxygen.
- An ammonia injection system to increase the PH up to 9.2 to limit corrosion.
- A tri-sodium phosphate injection system to increase PH at the high pressure boiler to limit corrosion.

#### **III.4.2.11.Processing of plant rejets**

##### **III.4.2.11.1.40H.E Wastewater treatment plant**

The system is a domestic wastewater treatment plant, located near the workshop. This wastewater treatment plant of the activated sludge type, is designed for a drift load of 40 H.E (inhabitant equivalent), will be made of fiberglass. The water arrives at the gravity treatment plant and is filtered, there is air injection to improve the bacterial degradation of the organic matter, the treated water is evacuated to the discharge and the recovered sludge is disposed of with truck to the outside.

##### **III.4.2.11.2.Water / oil separators**

Less than 0.85 and includes: a filtration compartment; a separator compartment. The hydrocarbon separator treats a flow rate of 10 l/s for light liquids of density is it ensures the pretreatment of water polluted with light hydrocarbons by coalescence on cross linked polyurethane filter materials.

##### **III.4.2.11.3.Atmospheric Emission control**

This system allows us to analyze the atmospheric emissions after the combustion of the gas turbine and gives the different results such as NO<sub>x</sub>, SO<sub>x</sub>, CO<sub>2</sub>, dust and various toxic gases. This system works with a FID type chromatograph (ionized flame detector), it gives

the analyzes periodically and is compared with the standard. These analyzes allow us to know the operating state of the gas turbine.

### III.4.2.12.TG and TS Safety Procedures

#### III.4.2.12.1 Gas Turbine

a) Trip TG:

Triggering the TG will cause all TG fuel shut-off valves and all measures to ensure safe shutdown.

b) Fast Charge Drop and TG Trip (PLST):

A PLST is a rapid protection charge drop followed by a TG trip. The TG load is reduced with a defined load gradient and by reaching the rated speed without load all TG fuel shut-off valves close immediately. Triggering occurs when it is obvious that the responsible triggering does not disappear during the charge drop. Then a rapid closure of the fuel shut-off valves is performed immediately after the rated speed without load is reached. A PLST can be activated by TG internal criteria or from external systems.

c) TG Fast Load Drop (PLS):

A PLS is a fast load drop protection. The TG load is discharged with the same load gradient as the PLST, but the TG will remain at rated speed without load for several minutes before the rapid closure of any TG fuel valves.

The purpose of a PLS is on the one hand to achieve stable temperature conditions and on the other hand to put within safe limits the process parameters causing the malfunction by reducing the TG load as quickly as possible and leaving the TG at speed rated without load for several minutes. A PLS can be activated by TG internal criteria or from external systems.

d) Emergency Shutdown of SEV Burners:

The TGs have the ability to initiate the SEV burners internally only by stopping the SEV burner fuel valves. TG will therefore be relieved until nominal operation on EV burners only.

#### III.4.2.12.2.Steam Turbine

a) Steam Turbine Release:

A steam turbine release means the closing of all shut-off valves and control valves of the steam turbine. Instantly, the bypass valves open and the HP steam are poured into the steam line to be reheated, the reheated steam and the LP steam into the condenser.

The operator must decide whether the gas turbine continues to operate with the same load or whether the TG must reduce its load.

No other system is affected by a tripping of the steam turbine. A triggering of the steam turbine can be activated by TS criteria or due to a system external to the TS.

b) Steam bypass system:

A triggering of the steam bypass system is achieved by a re-energization of the corresponding solenoid valve.

The shut-off valves and the control valves of the steam bypass system close quickly. [2]

**IV. Conclusion:**

Shariket Kahraba TERGA and the other power plants play a role crucial in the provision of electrical energy and in the promotion of economic development. It is important to manage these installations in a responsible and sustainable way, taking care of safety, energy efficiency and environmental protection.

Safety is a major concern for power plants, and measures must be taken to minimize the risks to workers, the facilities and the surrounding communities.



---

# CHAPTER 02

## **RISK MANAGEMENT AND ANALYSIS METHOD**

---

## I. Introduction

In general, risk means being exposed to the unpredictable. Risk refers to the probability of a loss or undesirable event resulting from an action, inaction or external incident. Many managers tend to focus on profitability, which is difficult to control, rather than on risk or exposure to risk, which can indeed be controlled or managed.

Risk management involves determining the level of risk to be taken, and measuring and adapting the current level of risk to maximize the value of the company, the portfolio or the individual's overall satisfaction.

It's not about reducing risk; it's about understanding and accepting those risks that enable us to achieve our objectives and reach an acceptable level of loss, and monitoring and modifying them on an ongoing basis.

Effective risk management is not necessarily limited to avoiding loss, but rather to providing a comprehensive framework that rigorously establishes the decision-making process before, during and after the occurrence of a risk. Since risk exposure is constantly evolving, risk management needs to be reviewed and reassessed on a regular basis.

In order to organize activities within the sector concerned and manage their risks, all industrial hazards must first be identified and integrated in order to develop management techniques conditioned by iso standards. These regulations classify industrial hazards into 4 categories:[7]

- Iso 9001 for quality management
- Iso 14000 for environmental management
- Iso/iec 27001 for information security management
- Iso 31000 for process of risk management described

Now, In this chapter of our dissertation will be devoted to defining the basic concepts of "risk", "hazard" and "accident"...etc

We will also develop the risk management process and some examples for industrial risks, and we finish with risk analysis tools.

## II. Base Definitions

Various similar definitions exist for health and safety terminology. The definitions offered below arise from a combination of authoritative sources.

### II.1. Hazard

The dictionary definition of hazard is “chance, risk, danger” and hazardous is “risky” which is of little help in distinguishing between the terms hazard and risk for the purpose of assessing and evaluating risk. For health and safety purposes the definition of hazard is “the potential to cause harm”. This is a very broad definition and in many ways can be interpreted to mean anything. It would be helpful therefore to categorise hazards to make identification easier. Hazards may be either:

- ✓ Physical e.g. machinery, electricity, heat, noise, gravity.
- ✓ Chemical e.g. water, acid, alkali, oils.
- ✓ Biological e.g. HIV virus, legionella, hepatitis virus (usually a disease causing agent).
- ✓ Ergonomic e.g. physical stress, wrongly sited controls and indications.
- ✓ Psychological e.g. workload/pressure/hours of work, trauma.



## II.2.Risk

Again from the normal use of the word .the dictionary definition is “chance of disaster or loss”. Clearly this implies a certain probability of occurrence or likelihood. Again for the purpose of assessing and evaluating risk this must be clear and is defined as “the probability of harm from a particular hazard being realised”.

For example noise is a hazard i.e. has the potential to cause harm. The risk is the likelihood that it actually will cause harm. Clearly this is dependent on a number of different factors (risk factors) such as how loud the noise is, how long an individual is exposed to the noise, the frequency of the noise, the individuals’ personal characteristics / predisposition to suffering with noise related effects, previous exposure and so on. [8]



## II.3.Harm

Harm represents physical injury, death, ill health, property and equipment damage and any form of associated loss [9]

## II.4.Accident

A combination of failures and conditions that enables an unwanted, unplanned event to occur resulting in loss or injury[9]

## II.5.Incident

An incident is an event, which represents deviation from the intended sequence of designed steps. Commonly defined as an unplanned event, which does not result in Injury or Damage a “Near Miss” is by definition an Incident [9]

## II.6.Safety

Often thought of as representing the level of security and freedom from harm. There is no such thing as complete safety, an appropriate definition might be “the maximum level of risk a person or organisation is prepared to accept [9]

## II.7.Severity

This requires an assessment or evaluation of the possible outcome(s) if the hazard was not sufficiently controlled and things went wrong. This can be assessed by relating to accident statistics or common sense. In some cases the information can be obtained from manufacturers' data, published guidance or other published information. In selecting the appropriate category it is important to be realistic.[8]

## II.8.Likelihood

This requires an assessment or evaluation of the likelihood (probability) of the hazard resulting in a loss. Consideration will need to be given to the following:

- Where is the hazard?
- How many people are affected?

- How knowledgeable are they?
- How many times does the hazard occur (frequency)?
- What is the extent of possible exposure (duration, time, concentrations etc)?

### II.9.Exposure

In the present context, exposure refers to contact between the hazard and a person, which can result in damage. Without exposure, there is no possibility of harm. So risk is therefore the probability that someone will be affected by a hazard.[10]

### II.10.Damage

Industrial damage can be defined as the negative effects of a hazardous event:

Personal injury related to an industrial hazard refers to the harm suffered by employees during an industrial accident, as well as the harm suffered by people living in the vicinity of the accident site. Such damage may include the development of illnesses caused by the pollution generated by the accident, serious injuries requiring prolonged rehabilitation, loss of professional income, severe physical or mental suffering, cosmetic damage, loss of quality of life, etc. Material damage to property belonging to the insured or to a third party as a result of its deterioration or breakage[11]

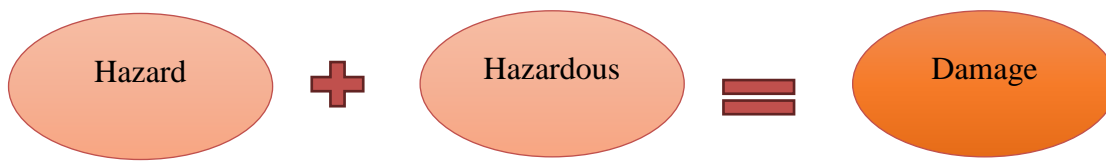

## III. Industrial risk definition

An industrial hazard is an incident that mainly occurs when hazardous products or processes are handled on an industrial site. It is important to note that an industrial risk has serious and immediate consequences for individuals, industrial facilities and the environment. To avoid accidents in the industrial field, legislation establishes the necessary industrial and technological risk management and prevention measures.[7]

### III.1. Classification of industrial risks

**Table 2.1: Classification of industrial risks.**

Origine	Example of risk
Economic and financial risk.	-Risks relating to company image, foreign exchange and interest rates ...
Political and regulatory risk.	-Change of government, legislation, civil liability,..etc
Natural risk.	-forest fire, flood, cyclone, storm, earthquake, etc.
Human and psychosocial risk.	-Risks of illness, repeated absences of personnel and work stoppages,

	-Lack of skills. -stress, workload, etc.
Technological risk.	-Risk of the emergence of new techniques and new products.
Logistics risk.	-Risks due to pedestrian, vehicle and public transport movements, -Risks due to handling and moving goods. -Risks due to movement within and outside the company.
Biological and chemical risk.	-Risk due to the transmission of biological agents,.. -Risk of accidental or chronic poisoning, fire or explosion.
Physical activity risk.	-Risks related to noise, vibration, radiation, etc. -Electrical risk, shocks, cuts, punctures, severing, etc

## IV. Risk Management

### IV.1. Risk management definition

Risk management is common to all types of business. The objectives may concern, for example

- Improving profitability and productivity.
- Managing costs and deadlines
- Product quality....

Risk management can be defined in its broadest sense represents the successful control of all threats of harm and loss to an organisation, group of people or an individual [9]

### IV.2. Risk assessment

A risk assessment is a systematic process used to:

- Identify what could cause injury or illness in your business (hazards).
- Decide how likely it is that someone could be harmed and how seriously (the risk).
- Take action to eliminate the hazard, or if this isn't possible, control the risk.

Assessing risk is just one part of the overall process used to control risks in your workplace[12]

As an employer, you are required by law to protect your employees, and others, from harm.

### **IV.3. Principles of risk management**

The principles of risk management are the identification, measurement and / or evaluation and economic control of risks that threaten the assets or earnings of a company or enterprise. In many countries specific legal requirements exist, but legal standards such as ‘adequate’, ‘suitable and sufficient’ and ‘so far as is reasonably practicable’ require active management rather than passive minimal compliance. This requires employers to develop effective ways of meeting those responsibilities and targets. Risk management is the cornerstone of modern health and safety law.

The modern style of criminal law demands active management of risks, not just compliance with prescribed standards. Risk management decisions can avoid or reduce any adverse financial impact upon an organisation. Where the legal duty is ‘so far as is reasonably practicable’ a computation between cost and risk is necessary requiring active management of risks.

Particularly for multi-national companies, effective risk management is a priority in judging their responses to business pressures on a worldwide scale. Demands on any business resource and risk management techniques will enable the management to make educated decisions on their ‘risk appetite’ (risk avoidance or risk acceptance) in balancing competing factors such as cost and control. There are always competing [13]

Three good reasons why the effective management of health and safety is important to any (not necessary in order of priority)

- ✓ Moral\ Humanitarian.
- ✓ Legal.
- ✓ Economic.

### **V. Risk Management Process**

To prevent risks from marring your organization's architecture, it is important to be able to identify, analyze and control them as early as possible. To achieve this, the diagram below presents the seven phases of risk management process:

- ❖ Establishing the context.
- ❖ Risk identification.
- ❖ Risk analysis.
- ❖ Risk evaluation.
- ❖ Risk treatment.
- ❖ Communication and consult.
- ❖ Monitor and review.

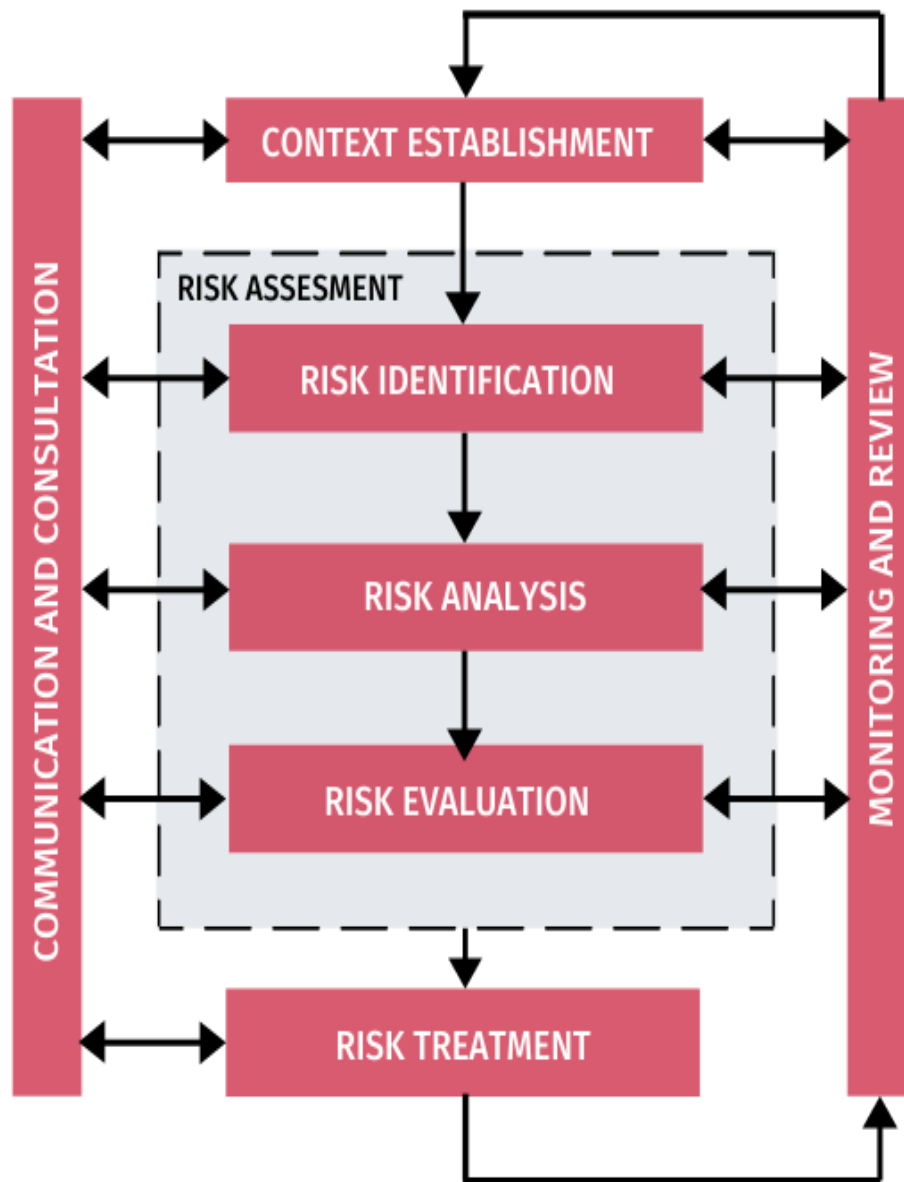

**Figure 2.1: Risk Management Process.**[14]

Risk management is an ongoing process, not a one-off task. Regular monitoring and review are essential to the success of your risk management approach. Ongoing monitoring ensures that risks are correctly identified and assessed, and that appropriate controls are in place. It also provides an opportunity to learn from past experience and constantly improve your risk management approach.[15]

### **V.1. Risk identification:**

Risk identification in information security aims to determine what could cause a potential loss to an organization's assets and gain insight into how, where, and why the loss might happen.[16]

To do this, several sub-steps need to be performed:

- ✓ Identification of assets.

- ✓ Identification of threats.
- ✓ Identification of existing controls.
- ✓ Identification of vulnerabilities.
- ✓ Identification of consequences.

### V.2.Risk Analysis:

Risk analysis is defined as "the use of available information to identify available to identify hazardous phenomena and estimate the risk"[17]

This phase consists of the following points:

- The first step in a risk management approach is to identify, as exhaustively as possible, all the sources of hazards and associated scenarios that could lead to damage. This is possible once the system under study has been identified and the scope of the study has been determined;
- Following this identification, the estimation of each accident scenario must consider the two components of the risk:
  - The probability (or frequency) of occurrence;
  - The associated potential consequences (severity).

This estimation can be carried out using methods such as: RPA, HAZOP, FMECA, ADD..., individually or combined.

$$\text{data privacy risk level} = \text{likelihood} \times \text{severity}$$

### V.3.Risk evaluation

The output from the risk analysis phase is then used as the input to risk evaluation.

Levels of all risks need to be compared against risk evaluation criteria and risk acceptance criteria, which have been developed during the context establishment phase.

In information security, risk acceptance criteria provide instructions about who is authorized to accept specific levels of risk and under what conditions. The following tables provide examples of risk acceptance and evaluation criteria: [16]

Table 2.2: Risk acceptance and evaluation criteria.[14]

Risk value	Acceptance criteria action
Low	Can be accepted without documented justification.
Moderate	Can be accepted provided that continual monitoring is in place. Treatment plans need to be investigated and implemented where required.
High	Can be accepted by senior management with adequate documented justification and where possible mitigating treatment plans are implemented immediately.
Risk value	Evaluation criteria action
Low	Reduce risk considering the cost of prevention compared to a reduction in risk.
Moderate	Action must be taken. Where the impact is major, urgent action must be taken.
High	Urgent action must be taken.

The output from risk evaluation will be the risk register, a list of risks prioritized according to risk evaluation criteria.

In data privacy, risk evaluation will need to be performed slightly differently, which also means that actions that will be taken will differ.

This is because any risks to individuals’ rights and freedoms originate in the processing of personal data.

This, in turn, means that based on the risk assessment outcome, every processing activity will be marked as “go” or “no go” for processing.

Additional actions might be mandatory consultations with data protection authorities or even representatives of data subjects whose personal data is to be processed

**V.4.Risk treatment**

This is probably one phase where it can get somewhat challenging when you want to leverage the risk management process as it is used in information security and apply it to the protection of personal data. This is because risks can be treated in several distinct ways in information security, depending on the organization’s risk appetite. Therefore, on the extreme end, a risk can even be accepted if risk acceptance criteria allow it. [16]

**V.5.Risk communication and consultation**

In information security, information about risks needs to be shared between decision-makers and other stakeholders. Such information may include the existence, nature, form, likelihood, severity, treatment, and acceptability of risks.

Effective communication among stakeholders is important since this may significantly impact decisions. [16]

Communication will ensure that those responsible for implementing risk management and those with a vested interest understand the basis on which decisions are made and why particular actions are required.

In data privacy, the communication about risks goes beyond information security. This is because, in many instances, stakeholders comprise a larger population than information security.

#### **V.6. Risk monitoring and review**

Risks are not static. Threats, vulnerabilities, likelihood, or consequences may change suddenly and without indication.

Therefore, constant monitoring is necessary to detect these changes. This is performed by reviewing all risk factors to identify any changes early enough and to maintain an overview of the complete risk picture. [16]

### **VI. Risk analysis tools**

Today, risk analysis techniques are booming in terms of number and specialisation according to their areas of application. This section aims to illustrate the approaches to risk management mentioned above.

#### **VI.1. Classification of risk analysis methods**

##### **VI.1.1. Qualitative method**

A modeling of the installation whether in the form of a systemic model or a functional analysis, constitutes a prerequisite for all analyses. In fact, it allows the structuring the understanding of the system and its subsystems and elements. The results inform on the characteristics of the system: the weaknesses of the system...

##### **VI.1.2. Quantitative method**

Makes it possible to fill certain inadequacies of digital methods in areas where knowledge is poorly formalized or difficult to quantify. The results are those of calculating reliability, availability, etc...



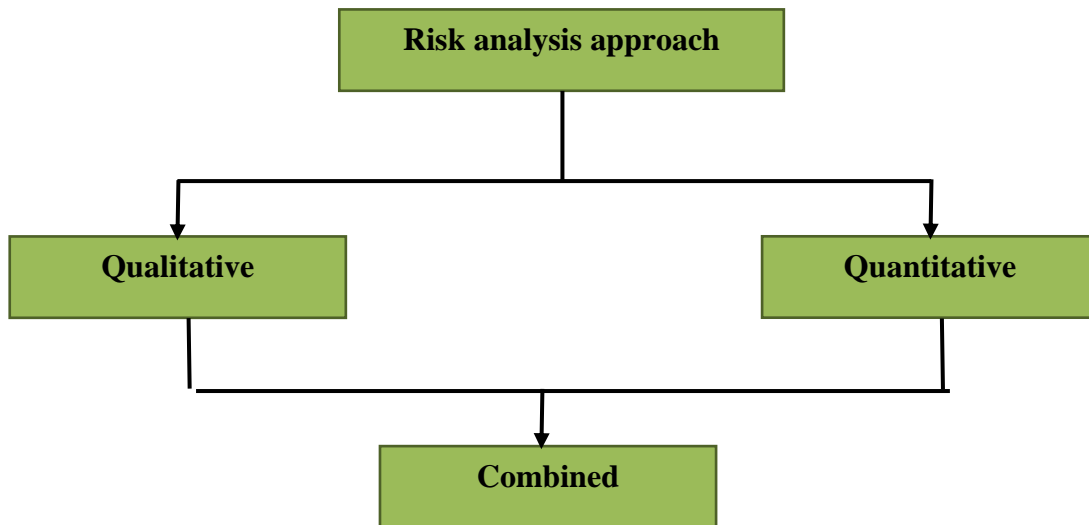

Figure 2.2: Typology of risk analysis methods.

### VI.1.3. Inductive / Deductive methods

#### VI.1.3.1. Inductive method

Correspond to an ascending approach where we identify all possible combinations of elementary events. Based on a descending approach, they consider an initiating event (technical failure, organizational dysfunction, etc.) which they seek to characterize the consequences on the system and its environment.

#### VI.1.3.2. Deductive method:

The approach is reversed, they consider a feared event (stopping the system, operating anomaly, etc.) of which they seek to explain all possible causes using a bottom-up approach.

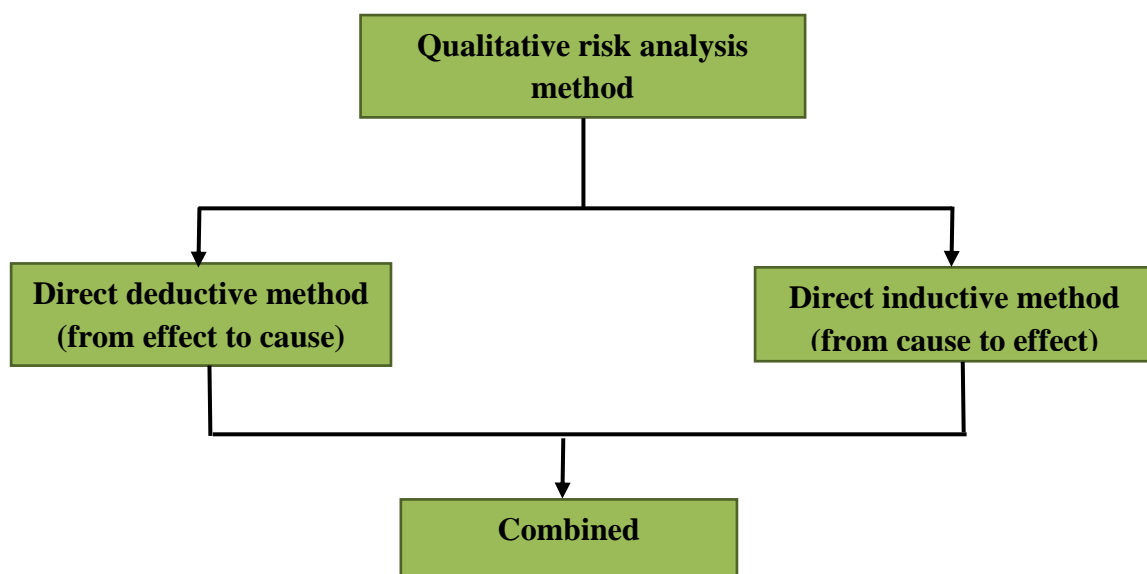
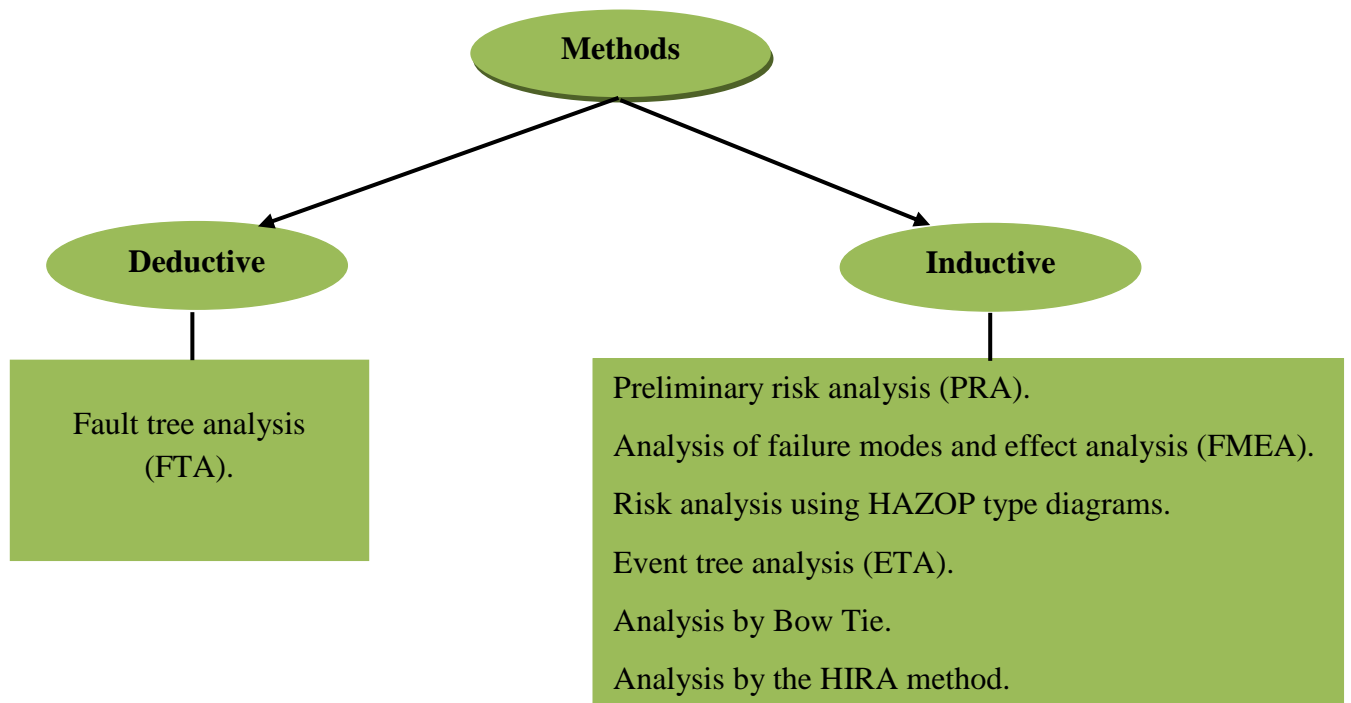

Figure 2.3: Typology of types of analysis method.

There are a number of tools available for detecting hazards and risks related to a process or installation, the following being the most commonly used.

- ❖ Preliminary risk analysis (PRA).
- ❖ Analysis of failure modes and effect analysis (FMEA).
- ❖ Risk analysis using HAZOP type diagrams.
- ❖ Fault tree analysis (FTA).
- ❖ Event tree analysis (ETA).
- ❖ Analysis by Bow Tie.
- ❖ Analysis by the HIRA method



**Figure 2.4: Risk analysis methods.**

## VI.2. The principal risk analysis tools

### VI.2.1. Preliminary risk analysis (PRA):

#### VI.2.1.1. History and scope

Preliminary Risk Analysis (Dangers) was developed in the early 1960s in the field's aviation and military. Used since in many other industries, the Union des Industries Chimiques (UIC) recommends its use in France since the early 1980s.[18]

Preliminary Risk Analysis (RPA) is a very general method commonly used for risk identification in the preliminary design stage of a facility or project. In consequence, this

method usually does not require knowledge in-depth and detailed description of the installation. In this sense, it is particularly useful in the following situations:

- **At the design stage of a facility**, when the definition is specified the process has not yet been completed. It provides an initial analysis of safety resulting in elements constituting a future operational and safety guidelines. It also allows choose the most suitable equipment.
- **In the case of an existing complex installation**, at the risk analysis approach. As its name indicates, the RPA is a preliminary step to highlight elements or situations requiring more attention and consequence of the use of more detailed risk analysis methods. It can thus be supplemented by a method of type AMDEC or tree failures, for example.
- **In the case of an installation whose level of complexity does not require no further analysis**, with regard to the objectives set out in the risk analysis.

#### **VI.2.1.2. Principle**

- Preliminary Risk Analysis requires at first identify hazardous elements in the facility. These hazardous elements most often refer to: Substances or preparations dangerous, whether in the form of raw materials, products finite, utilitarian...;
- Hazardous equipment such as storage areas, areas of receiving shipping, reactors, utility supplies (boiler...);
- Hazardous operations associated with the process.

The identification of these hazardous elements depends on the type of installation it should also be noted that the identification of these elements is based on the functional description carried out before the implementation of the method. From these dangerous elements, the APR aims to identify, for a dangerous element, one or more several hazard situations. As part of this document, a situation of hazards is defined as a situation which, if not controlled, may lead to the exposure of targets to one or more hazardous phenomena. The working group must then determine the causes and consequences of each hazard situations identified and then identify existing safety features on the system studied. If these are considered insufficient in relation to the level of risk identified in the criticality grid, proposals for improvements must then be considered.[19]

#### **VI.2.1.3. Limitations and Benefits**

The Main Benefit of the Preliminary Risks is to allow relatively rapid examination of dangerous situations on facilities. In comparison to the other methods presented below, it appears to be relatively economical in terms of time spent and does not require not a level of description of the system studied very detailed. This advantage is well intended to be linked to the fact that it is generally implemented at the facility design. On the other hand, the RPA does not allow to accurately characterizing the events likely to lead to a major accident for systems complex. As its name suggests, it is the basis of a method preliminary analysis that identifies critical points to be addressed the subject of more detailed studies. It helps to highlight the equipment or facilities that may require further investigation through tools such as FMEA, HAZOP or failure tree analysis. However, its use alone may be considered sufficient in the case of installations simple or where the working group has significant experience in type of approach.[19]

### **VI.2.2. HAZOP (hazard and operability study)**

#### **VI.2.2.1. History and field of application**

The term HAZOP was first used in official publications in 1983. In 1965, Britain's Imperial Chemical Industries, one of the world's largest chemical companies, decided to improve the performance of its processes and the safety of its facilities. The HAZOP method was originally developed for analyzing chemical process systems. It then expanded to other types of industrial systems. It is also translated into complex operating systems and software systems.

Most methods used at the time were based on the analysis of previously observed events. HAZOP offers an original approach by identifying installation hazards and defects a priori rather than ex post facto. Each process is analyzed taking into account all the parameters that control it. Therefore, every change in parameters is tracked and analyzed to detect possible malfunctions.

The HAZOP type method is a system evaluation tool specifically used for the risk analysis of thermo hydraulic systems, for which it is crucial to control parameters such as pressure, temperature, flow rate, etc. The procedure followed by HAZOP is very similar to that proposed by FMEA. HAZOP no longer considers failure modes but rather potential deviations (or deviations) of key parameters relevant to the operation of the unit. Therefore, it is installation-centric while FMEA is component-centric.

#### VI.2.2.2. Principle

The HAZOP approach is dedicated to risk analysis in thermo hydraulic systems to master parameters such as pressure, temperature, flow rate... HAZOP follows the procedure is very similar to that proposed by the FMEA. HAZOP does not consider no longer a failure mode, but an underlying drift (or deviation) in main parameters relevant for the operation of the device. So it is FMEA focuses on installation; Element. For each component (line or grid) of the system under review, the (conceptual) generation of drift is carried out systematically in conjunction:

- keywords such as “No”, “More”, “Less”, “Too much”;
- Parameters associated with the studied system. Parameters commonly the temperature, pressure, flow rate, concentration, but also time or operations to perform.

The working group must therefore work to determine the cause and potential consequences of each deviation and identification of methods existing systems can detect this drift, prevent it from occurring or limit the impact. If necessary, the working group can propose measures to take corrective action to achieve greater safety. Initially, HAZOP is not intended to estimate the probability of occurrence or the seriousness of the abuse or its consequences. Therefore, the tool sometimes the description is qualitative. However, in the area of major accident risks, a priori estimates of the probability and severity of consequences identifying biases is often necessary. In this case, HAZOP must the seriousness of the risk must therefore be analysed on the following basis: Simplified quantitative techniques. [19]

#### VI.2.2.3. The advantages and limitations

HAZOP is a particularly effective tool for thermo-hydraulic systems. This method has a systematic and methodical character just like FMEA. Considering, in addition, simply deviations of operating parameters of the system, it avoids between other to consider, as with FMEA, all possible failure modes for each component of the system. However, the HAZOP

does not allow in its classic version to analyze events resulting from the simultaneous combination of several failures. In addition, it is sometimes difficult to assign a keyword to a well-defined portion of the system study. This makes it particularly difficult to fully identify potential causes of a drift. Indeed, the systems studied are often composed of interconnected parts so that a drift in a line or mesh may have consequences or the inverse of the causes in a neighbouring cell and vice versa. Of course, it is possible a priori defer the implications of a drift from one part of the system to another. However, this task can quickly prove complex.

Finally, since HAZOP deals with all types of risks, it can be particularly long to implement and lead to an abundant production of information not concerning major accident scenarios.[19]

### **VI.2.3. Failure Tree Analysis**

#### **VI.2.3.1. History and scope**

Failure tree analysis was historically the first method developed for an examination risk management. It was developed in the early 1960s by the Bell Telephone and was tested for the evaluation of the security of missile firing systems. Aimed at determining the sequence and combinations of events that can lead to a dreaded event taken as reference, failure tree analysis is now applied in many fields such as aeronautics, nuclear, chemical industry... It is also used to analyse a posteriori the causes of accidents products. In these cases, the final dreaded event is generally known because observed. This is called tree-based analysis of causes, the main objective being to identify the actual causes that led to the accident.

#### **VI.2.3.2. Principle**

Failure tree analysis is a deductive method. Exist In fact, it is a frightening event defined a priori to determine a sequence of events or a combination of events can ultimately leading to

This incident. This analysis moves from one cause to another the basic event that can be at the origin of the event Fear. The basic events are generally:

- Elementary events that are sufficiently known and described by so that it is not useful to look for the causes. Thus, their probability of occurrence is also known;
- Events that cannot be considered elementary but whose causes will not be developed due to lack of interest;
- Events whose causes will be developed at a later stage new analysis for example;
- Events occurring normally and recurrently in the process or facility operation;
- Regardless of the nature of the basic elements identified, tree analysis failure is based on the following principles:
  - These events are independent;
  - They will not be broken down into simpler elements for lack of information, of interest or because this is impossible;
  - Their frequency or probability of occurrence can be assessed.

A Failure tree analysis is usually presented from top to bottom (see Figure 3). The higher only includes the event that we are trying to describe how it can happen. Each line details the top line by presenting the combination or combinations may produce the event of the top line to which they are attached. These relationships are represented by logical links OR or AND.

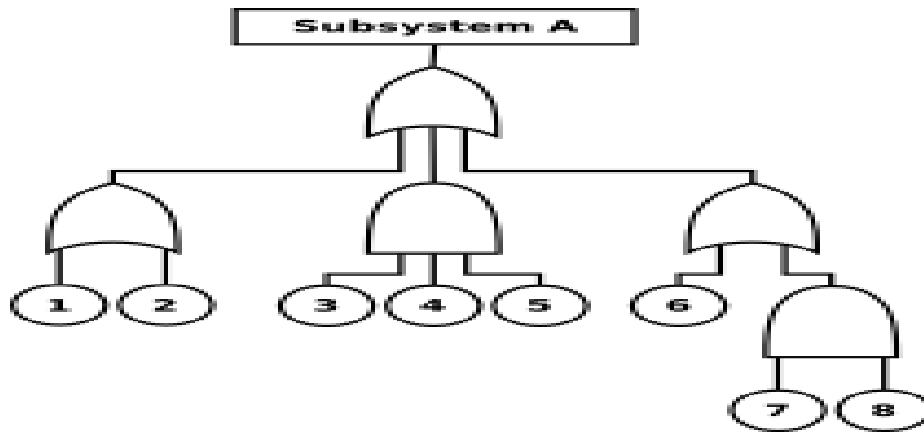

Figure 2.6: Failure Tree Analysis.

### VI.2.3.3. The advantages and limitation

The main advantage of failure tree analysis is that it allows considering combinations of events that can ultimately lead to a dreaded event. This possibility allows a good adequacy With the analysis of past accidents which shows that the major accidents observed most often result from the combination of several events which alone could not have led to such disasters. Moreover, by aiming at estimating the probabilities of occurrence of events leading to at the final event, it provides criteria for determining priorities for the prevention of potential accidents. Failure tree analysis focuses on a particular event and its application to any a system can be tedious. In this sense, it is advisable to implement beforehand methods of risk analysis. These tools make it possible to identify the most serious events that may be subject to a failure tree analysis and, on the other hand, to facilitate the determination of immediate, necessary and sufficient causes at the tree development level. For about fifteen years, computer software has been marketed to make easier the application of the fault tree. These tools are very useful for search for minimum slices, determination of probabilities as well as for presentation tree-shaped graph of results. [19]

## VI.2.4. Event Tree Analysis

### VI.2.4.1. History and field of application

The analysis by event tree was developed in the early 1970s for the assessment of plant risk light-water nuclear. Particularly used in the nuclear field, its use has spread to other sectors of activity. Due to its close complexity of the failure tree analysis, this method applies preferably on specific subsystems. It provides assistance valuable for handling systems with multiple security features and their interactions. Like the tree analysis of the failures of which it is based, it allows to estimate the probabilities of occurrence of sequences accidents. This method is particularly used in the field of the post-accident analysis to explain the observed consequences resulting of a system failure.[19]

### VI.2.4.2. Principle

Failure tree analysis, as we have seen previously, aims to determine, in a deductive approach, the causes of a adverse or dreaded event. Conversely, a tree analysis event involves the failure of a component or part of the system, and focuses on determining the events that result from it. From an event initiator or of an original failure, the analysis by event tree allows to estimate the drift of the system by systematically considering the operation or failure of detection, alarm, and prevention, protection or intervention... These devices may concern both

automatic and human (operator intervention) or organizational (application of procedures). The approach generally used to perform a tree analysis event is as follows:

- Define the initiating event to be considered;
- Identify the security functions intended to address them;
- Build the tree;
- Describe and exploit the sequences of events identified;

The following paragraphs describe these different steps following an example Guidelines for Hazard Evaluation Procedures references.

#### **VI.2.4.3. the advantages and limits**

Event tree analysis is a valuable tool to explore the potential consequences of an initiating event and the subsequent sequence of events that may or may not result in an accident. This method allows a comprehensive examination of the architecture of a situation, highlighting both its advantages and limitations.

The concept of safety encompasses various measures, including prevention, protection and response that are either already in place or can be considered for a particular location. Therefore, it is a valuable tool for retrospectively analyzing accidents.

The implementation of this approach can be quite cumbersome. Therefore, it is crucial to carefully determine the specific event that will be the subject of this analysis.

#### **VI.2.5. The Bow Tie Method**

##### **VI.2.5.1. History and scope**

Shell was a pioneer in the development of the bow tie method, widely used in various industries. This approach, known as tree type, provides a complete visual representation at a glance.

The causes that can lead to an accident, the resulting consequences and the preventive measures implemented. An adverse incident in the center of attention can be attributed to various potential factors, including Examples of loss of Containment includes the release of a deleterious substance, an explosion, a broken pipeline, an uncontrolled reaction, a breach in a storage tank, a ruptured substance, and other similar events. This particular tool is used to demonstrate the results of a thorough risk analysis, such as FMEA, HAZOP or What-if analyses, which are more complex than the initial risk assessments.

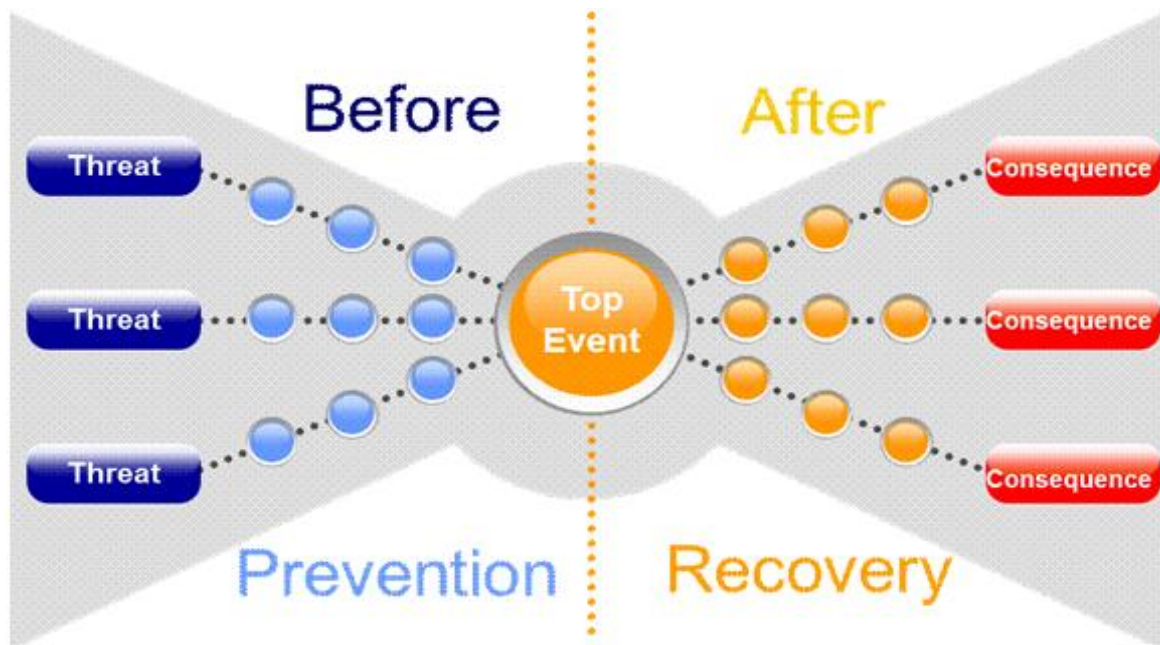

Figure 2.7: Bow Tie method.[20]

#### VI.2.5.2. The advantages and limitations

The Bow Tie offers a concrete visualization of accident scenarios that could from the initial causes of the accident to the consequences at the identified vulnerable elements.

Therefore, this tool clearly highlights the action of security barriers opposing these accident scenarios and provides an enhanced demonstration of the control of risks.

However, it is a tool whose implementation can be particularly costly by time. Its use must therefore be decided for cases effectively justifying such a level retail.[19]

#### VI.2.6. FMCEA

##### VI.2.6.1. History and field of application

FMECA (Failure Mode Effects and Criticality Analysis) was developed by NASA and the US military sector, was first used in the field of the aeronautics industry in the 1960s.

Its use has since widespread in other sectors of activity such as the chemical industry; In fact, it is essentially adapted to the study of failures of materials and equipment and may apply to systems of different technologies (electrical, mechanical systems, hydraulic systems...) that combine several techniques.

This analysis aims first to identify the impact of each failure mode of the components of a System on its various functions and then prioritizes these failure modes according to their ease of detection and treatment.

##### VI.2.6.2. Definition

Failure mode, effects and criticality analysis (FMEA) is a method of predictive reliability analysis that systematically identifies the potential failures of a device and then estimates the risks associated with the occurrence of these failures, in order to initiate the corrective actions to be taken to the device.



FMEA is a rigorous inductive analysis method that allows a systematic search:

- Failure modes of a means of production.
- Failure causes generating failure modes.
- Consequences of failures on the means of production.
- Detection means for the prevention and/ or correction of failures.

This analysis has two aspects: a qualitative aspect is to identify potential failures and the other a quantitative aspect is to estimate the risk associated with these potential failures.

- The qualitative aspect: The qualitative aspect of the study consists in identifying the potential failures of the functions of the studied system, to search and identify the causes of the failures and to know the effects that can affect customers, users and the internal or external environment.
- The quantitative aspect: The quantitative aspect consists in estimating the risk associated with the potential failure. The purpose of this estimation is to identify and prioritize potential failures. These are then highlighted by applying certain criteria, including the impact on the customer. The prioritization of failure modes in descending order, facilitates the search and taking of priority actions that must reduce the impact on customers or that would completely eliminate the causes of potential defects.

### VI.2.6.3. Principle

The analysis of Failure Modes and their Effects is based in particular on the concepts of:

- ✓ Identification of failure modes: the cessation of the fitness of an element or system to Perform a required function;
- ✓ Identify potential causes of each mode: the effect by which a failure is observed on An element of the system;
- ✓ 3. Estimated effects: events that lead to modes of failures;
- ✓ 4. Assessment of the criticality of these effects: the consequences associated with the loss, or the ability of an element to perform a required function.[19]

The analysis always begins with the identification of potential failures of the operating modes. It continues, by inductions in order to identify the potential effects of these failures (dangerous situation, hazardous event and damage). Once the potential effects are established, the risk is estimated and the control actions.

To advance in the analysis, it seems useful to summarize the FMCEA work in the following way: four questions are enough to give you a first approach of the logic followed and to help you understand that 'FMCEA is a way of thinking, a work method, not a form to be completed

**Table 3.1: The four basic FMECA questions.**

Potential Failure modes	Possible effects	Causes possible	Monitoring plan(Detection)
What could go wrong?	What could be the effects?	What could be the causes?	How to see this?

**VI.2.6.4. Purpose of the FMECA**

FMECA is a technique that leads to the critical examination of the design in one or evaluates and guarantee the operational safety (safety, reliability, maintainability and availability) of a means of production.

**VI.2.6.5. FMECA Objectives**

- When implementing and using a reliability assurance service.
- FMECA plays a key role. The methodological character makes it possible to adapt it to each system by modifying or deepening certain point according to the goal to be achieved.
- The FMECA is only a step in a program of reliability and maintainability that requires a set of complementary methods and means

**VI.2.6.6. Types of FMECA****a. Product FMECA :**

Product FMECA is used to help validate studies, this definition of a new product manufactured by the company. It is used to evaluate potential defects in the new product and their causes. This evaluation of all possible defects will enable them to be remedied, after prioritization, by the implementation of corrective action on design and preventive action on industrialization.

**b. Process FMEA:**

Process FMEA is used to study potential defects in a new or existing product, caused by the manufacturing process.

**c. FMECA for production equipment:**

This is used to study production equipment at the design stage, or during the operating phase for a production facility in operation. Carrying out a FMECA makes it possible to analyze the real cause of a failure leading to degradation in production system performance.

**VI.2.6.7. The FMEA approach**

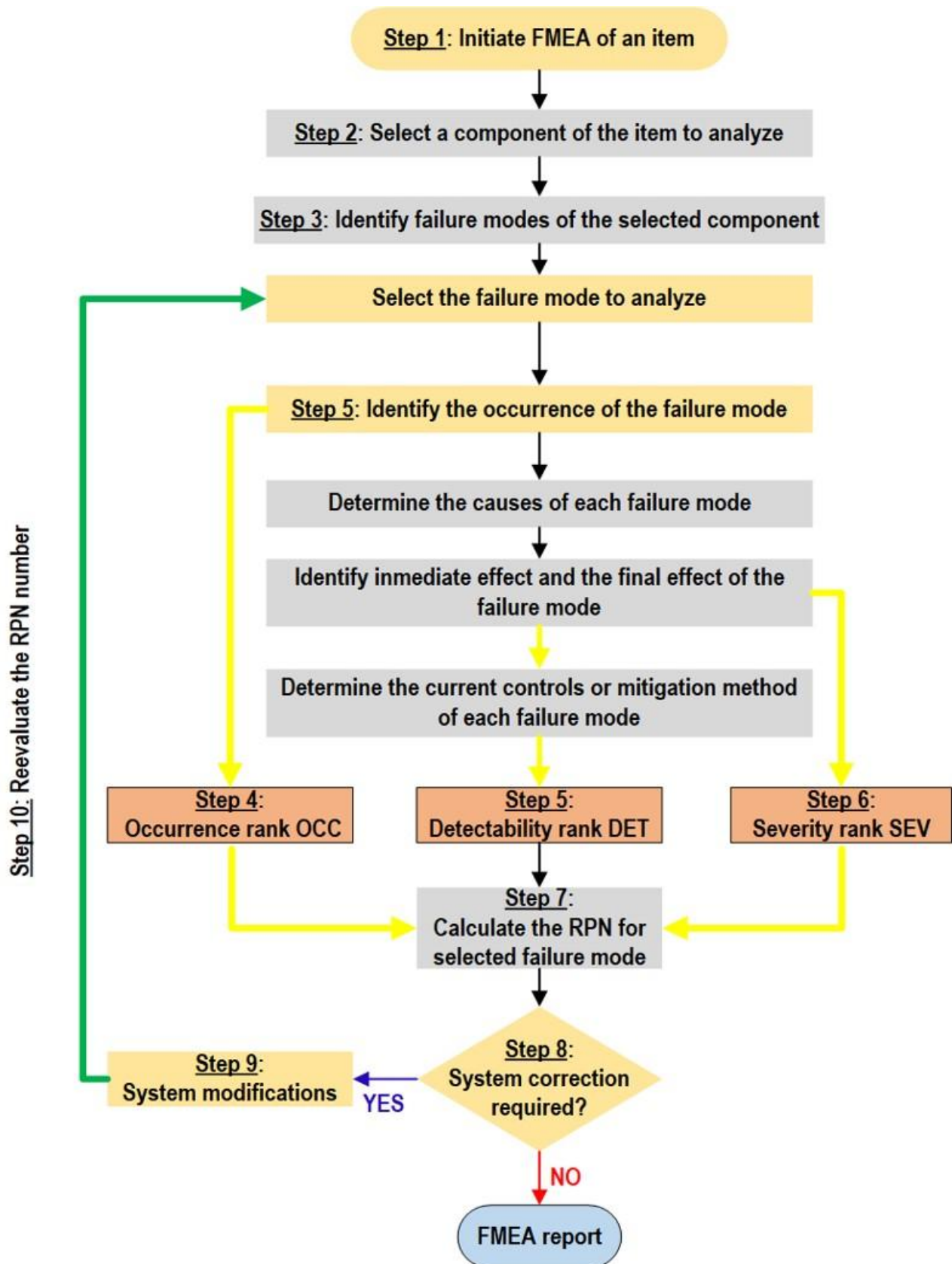

Figure 2.5: The FMECA approach.[21]

**VI.2.6.8. Limitations and advantages**

FMECA is very effective when implemented Works on analysing simple failures of components that lead to failure from the system. Due to its systematic nature and research network are a valuable identification tool Potential errors and ways to limit or prevent their effects Appear. Since it includes checking for each failure mode, the causes and effects of different operating states of the system, FMECA identifies common failure modes that may have an impact System checked. Common failure modes include an event that occurs due to its nature or dependency on certain components causes error conditions in multiple system components simultaneously. Typically, there will be a supply failure or major external aggression Common failure modes. Especially systematic FMECA is very complex, has a large number of decompositions, and is very difficult to execute, especially this is tedious considering the amount of information that needs to be processed. This if the system under consideration has many states, the difficulty increases tenfold Operation. Additionally, FMEA takes into account simple errors and can According to the needs of analysis; it can be effectively supplemented by appropriate methods.[19]

**VII. Conclusion**

Risk analysis methods take full value in the process of risk management as long as it largely determines the relevance of the other steps in this decision-making process. These methods are classified according to their: approaches, typologies, approaches and formalism. Of course, each method of risk analysis has its advantages and limitations. But it must be remembered that there is no good or bad method of risk analysis but they are complementary.

The choice of the method or methods necessary to perform the risk analysis is paramount. However, there is no one-size-fits-all approach to this analysis. It depends, in particular, on the objectives of the study and the availability of the computer tool that supports the method to be chosen. In this chapter, we have tried to better situate the risk analysis methods, after identifying the benefits and limitations of the methods.



---

# CHAPTER 03

## **RISK ASSESSMENT AND APPLICATION OF FMECA**

---

## I. Introduction

Power plant management is a top priority and is essential to ensure safe, reliable and efficient operation.

In the context of the SKT power plant, this is even more important given the environmental, economic and social issues associated with electricity generation. It is therefore essential to develop effective methods for identifying, assessing and mitigating potential risks.

Risk assessment enables the identification, analysis and control of potential hazards that may affect infrastructure, processes and personnel.

The SKT power plant, as a key player in electricity generation, must adopt rigorous practices to proactively assess and manage these risks.

In this chapter, we will examine the risks present in the power plant that we encountered during our internship and their assessment. We choose the FMECA method, which is a fundamental research method for analyzing failure modes and dealing with them before they occur, with the aim of reducing risks and eliminating them as far as possible. To ensure the safety of personnel and installations, equipment must comply with strict, proven rules.

## II. Risk assessment In the power plant

### II.1. Work at height

Work on frameworks, roofs, towers, platforms, access to elevated areas: ladders, stairs, footbridges, etc. Pylons or other work equipment (scaffolding, tankers, etc.).... Whether temporary or regular, working at height can be a dangerous activity. Falling from a height is indeed the second reason. Fatal work accident after a traffic accident. To avoid falls from height, it is necessary to Design works or equipment, workstations and operating procedures.

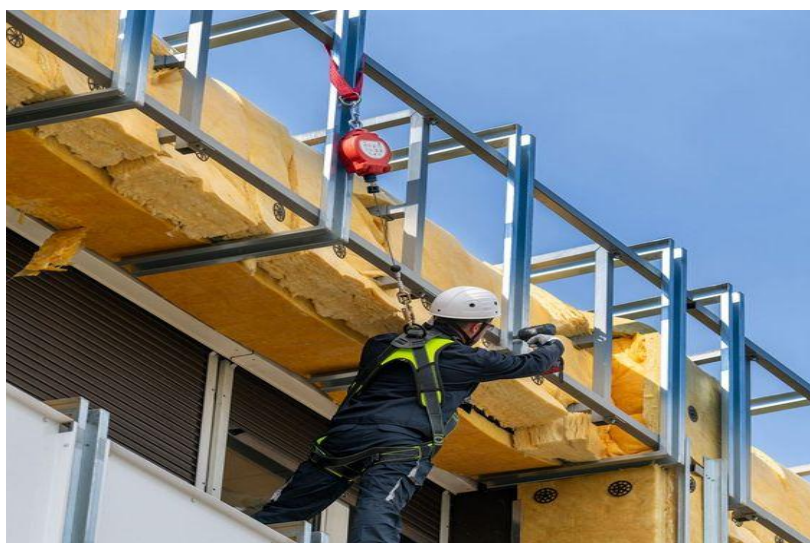

Figure 3.1: Work at height.[22]

**❖ Potential risks**

- Falling objects.
- Fall of persons.
- Injury.
- Material and tools falling down.
- Pipe rack falls down.

**❖ Causes of risk**

- Lack of collective protection (nets, lifelines...).
- Inadequate Risk Assessment.
- Poor Edge Protection.
- Lack of experience.
- Non-compliant scaffolding.
- Lack of equipment suitable for work at height.
- Slipping on scaffolding walkways.
- Presence of obstacles in walkways, Disorder.

**❖ The prevention approach**

- From the design stage of a structure or piece of work equipment.
- In the analysis of the workstation.
- In the analysis of operating procedures for installation and maintenance work.

**❖ Preventive measures**

- Authorization.
- Work permit.
- Certified scaffolding.
- Mark out work areas.
- The scaffolding should be based on graded soil with good foundation.
- Removing the garnet from the boards to avoid stress on the scaffolding.
- Tools put in the tool bag according to their capacity.
- Prohibit work at height if the weather affected the safety of persons.
- Prohibition to work at heights of night.
- Protection of persons with safety harnesses (Wear PPE).
- Analyze your fall distance.
- Keep the site clean.
- Avoid overlapping work.

**II.2.Lifting**

Lifting is a high-risk activity. Equipment and machinery for lifting loads or people represent major risks for the safety of workers and users on work sites. Several types of equipment

(tower cranes, aerial work platforms, lifting platforms, etc.) pose risks to people and property, often due to simple negligence that can be avoided by good driver training, compliance with regulations and a few rules.



Figure 3.2: Lifting operation.[23]

❖ **Rules for using lifting equipment**

- Choice of lifting equipment.
- Maintenance and checking.
- Use of lifting equipment.
- Training of personnel responsible for using lifting equipment.

❖ **Risk**

- Fall from height and hurt workers.
- Component fall down.
- Component collides with other things surrounded.
- Collision with person.
- Falling materials.
- Poor visibility for the driver.
- Crane tilt.
- The collapse of the crane.

❖ **Causes of risk**

- Incorrect handling.
- Inadequate lifting operations.
- Absence of markings on work areas.
- Incompetent crane operator.



- Condition and quality of lifting accessories.
- Work without a lifting plan.
- Standing underneath the suspended load during the hoisting operation.
- Poor control and maintenance of lifting machine.
- No barricades for the lifting zone.
- The collapse of the crane due to overloading.

❖ **Preventive measures**

- Authorization.
- Work permit.
- Mark out the workplace.
- Respect load weights.
- Check condition of slings.
- Follow lifting plan.
- Staff training and information.
- Wear appropriate PPE.
- Proper training in safe lifting techniques and ergonomic practices.
- Maintain a safe distance between the load and people.
- Examination, inspection and maintenance.
- Competency of personnel involved in the lifting operation.

### II.3. Confined spaces

Confined spaces are present in many sectors of activity, and thousands of employees are affected. In these spaces, the risks generated by an oxygen-depleted, toxic or explosive atmosphere are very real, and are added to other serious risks such as falling from a height or drowning. These risks are often the cause of serious or fatal accidents. The majority of accidents, often serious or even fatal, which occur during work in confined spaces, are related to an oxygen-deficient atmosphere, the presence of toxic gases or vapors, or an explosion or fire.



Figure 3.3: Confined space [24]

**❖ Risks Potential**

- Toxic conditions.
- Asphyxiation.
- Flammable atmosphere.
- Free-Flowing Liquids and solids.
- Heat.

**❖ Causes of risks**

- Inadequate risk analysis.
- Lack of communication of information between user companies and contractors.
- Companies. Certain risks related to the process or installation may not be known to the operators carrying out the maintenance.
- Unidentified risks of chemical reactions between incompatible substances or anaerobic fermentation of plant, animal or household waste, sludge, etc.
- Inadequate atmosphere control before and during work.
- Inappropriate lockouts or safety measures for installations.
- Unsuitable protective equipment.
- Lack of communication between operators.
- Inadequate supervision and monitoring of work.
- Inadequate training of personnel working near or in such areas.
- Lack of procedures for dealing with incidents or accidents.

**❖ Preventive measures**

- Identify potential hazards such as toxic gases, oxygen deficiency, flammable atmospheres, and physical hazards.
- Provide comprehensive training to all workers who will enter confined spaces about risks potential and emergency procedures.
- Permit-to-work.
- Ensure proper ventilation to remove hazardous gases and supply fresh air (mechanical ventilation or natural ventilation).
- Use gas detectors to monitor the atmosphere inside.
- Establish a reliable communication system between workers.
- Clearly mark entry and exit points.
- Take regular breaks.
- Regular health checks.
- Personal Protective Equipment (PPE): gloves, safety shoes, lumbar belts, etc.

**II.4. Manual handling**

Manual handling is a common cause of back injuries, usually due to poor posture. Like

mechanical manipulation, it can cause bruises, crushes and falls. In addition, angular or rough surfaces, falling objects and thrown objects are the main causes of injuries, tears or abrasions during manual handling

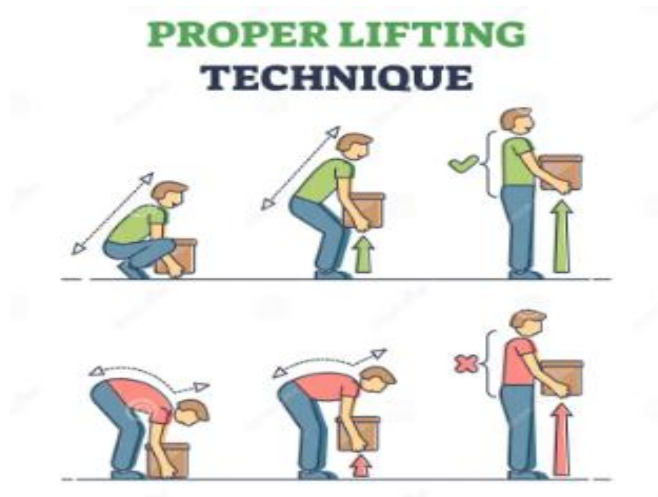

Figure 3.4: Proper Lifting Techniques Diagram.[25]

#### ❖ Potential risks

- Falling people and loads.
- Personal injury.
- Cutting, crushing.
- Degradation of the state of the object.

#### ❖ Some factors can aggravate the painfulness of manual handling

- Load-related factors: weight, size and shape of the load, load located at height or to be deposited at height.
- Factors related to work premises: cramped workspace, cluttered floor, in poor condition, slippery...
- Ambient factors: cold atmosphere (cold storage) or hot atmosphere (foundry), bad weather, noise.
- Organizational factors: fast pace, repetitive gestures, emergency work, shift work, night work.

#### ❖ Preventive Measures

- Provide comprehensive training on proper lifting techniques, posture, and body mechanics.
- Use of Mechanical Aids.
- Weight limits and team lifting.
- Proper storage and organization.
- Provide appropriate PPE, such as gloves with good grip, to assist with manual handling tasks.

- Use clear signage to indicate heavy items and provide instructions for safe handling.
- Instruct workers to:
  - Plan the lift and ensure the path is clear.
  - Keep the load close to the body.
  - Bend at the knees, not the waist, and use leg muscles to lift.
  - Avoid twisting or turning the body while lifting or carrying.
  - Use smooth, controlled movements.

### **II.5.Mechanical handling**

Mechanical handling involves the use of lifting equipment, such as cranes, self-propelled forklifts and overhead cranes....

Mechanical handling means reducing heavy manual handling activities, speeding up the flow of goods and improving logistics performance. But the operations performed by the forklift operators are not without risks for themselves and their colleagues. The most frequently used mechanical handling equipment in work sites are the following:

- ✓ Lifting: Bridge cranes, hoists.
- ✓ Lifting and transport: forklifts.
- ✓ Traction: Capstans, tractels, tirlors, pull-lifts, etc.
- ✓ Auxiliary elements: Cables, ropes, lifting hooks, chains, slings, etc.

#### **❖ The potential risks**

- Injuries of people.
- Collision with moving machines.
- Overturning of machines and loads.

#### **❖ Causes**

- Mistakes made by operators, such as improper use of equipment, lack of attention, or inadequate training.
- Exceeding the weight limits of mechanical handling equipment.
- Incorrect procedures for loading and unloading materials.
- Inadequate lifting operation.
- Condition and quality of mechanical handling equipment.

#### **❖ Preventive Measures**

- Ensure a flat and obstacle-free surface to minimize the risk of tipping machines.
- Clearly separate the traffic areas of the handling machines from the pedestrian paths to avoid collisions. Respect.
- The speed limit of gear.
- Do not stand near lifting devices.
- Clearly mark hazardous areas and provide adequate warning signs to alert personnel.

## II.6.Hot work

The use of ignition sources close to flammable materials is called “hot work”. Welding, brazing and cutting are examples of heat treatment. Fires are usually caused by performing ‘quick five-minute’ tasks in an area that is not reserved for welding or cutting. Obtaining a Permit before carrying out hot work is one-step in a hot work management plan to reduce the fire risk associated with hot work in areas containing flammable or combustible materials.



Figure 3.5: Welding.[26]

### ❖ The different types of hot work

- Electric arc welding.
- Gas torch welding.
- Torch welding of bitumen strips during waterproofing work.
- Cutting.
- Grinding.
- Flame cutting.

### ❖ Risks Potential

- Risks Sparks.
- Burns from flying particles.
- Damage to eyes.
- Electrification/Electrocution.
- Intoxication by fumes.
- Fire hazards.
- Explosion.

### ❖ Causes of risks

- Sparks and molten metal ignite flammable materials.
- Accumulation of flammable dust leads to explosions.
- Vapors from flammable liquids or gases.
- Confined spaces with inadequate ventilation.
- Exposure to fumes, gases and dust.
- Faulty electrical connections.

#### ❖ Preventive measures

- Hot work permits.
- Wearing of specific PPE.
- Presence of fire extinguishers in the work area.
- Monitor the atmosphere for flammable gases and vapors using gas detectors.
- Isolate the hot work area from other operations to prevent the spread of fire.
- Keep the work area clean and organized to avoid the accumulation of flammable materials.
- Inspect and clean equipment regularly to avoid malfunctions and fire hazards.
- Never light the torch with a gas lighter, as it may explode in your hand.
- Earthing the welding unit.
- Do not leave unused generators switched on.
- Use local exhaust ventilation (LEV) systems to capture contaminants at source.
- Do not leave oxygen and acetylene cylinders in a confined space. They should be placed upright on the floor and away from heat sources.

### III. Major risks

#### III.1. Fire Risk

Fire risk is the probability that a fire will occur in a given area and cause damage to life, property or the environment. Assessing fire risk involves analyzing various factors to understand the likelihood and potential consequences of a fire.

#### ❖ Principal causes of fires

- Faulty electrical equipment: short circuits, overloads and poorly maintained electrical appliances.
- Discarded cigarettes.
- Sparks from welding, grinding or other industrial equipment.
- Flammable chemicals.
- Climate change.
- Negligence.
- Lightning.

#### ❖ Professional risk prevention

Fire risk reduction involves the implementation of a set of preventive measures, safety practices and preparedness strategies. The following are some effective systems for reducing and protecting against fire in the Terga installed power plant with a capacity of 400 MW:

✓ Fire extinguishing system deluge spraying system sgc 22:



Figure 3.6: System deluge.[27]

✓ Fire extinguishers and their types:

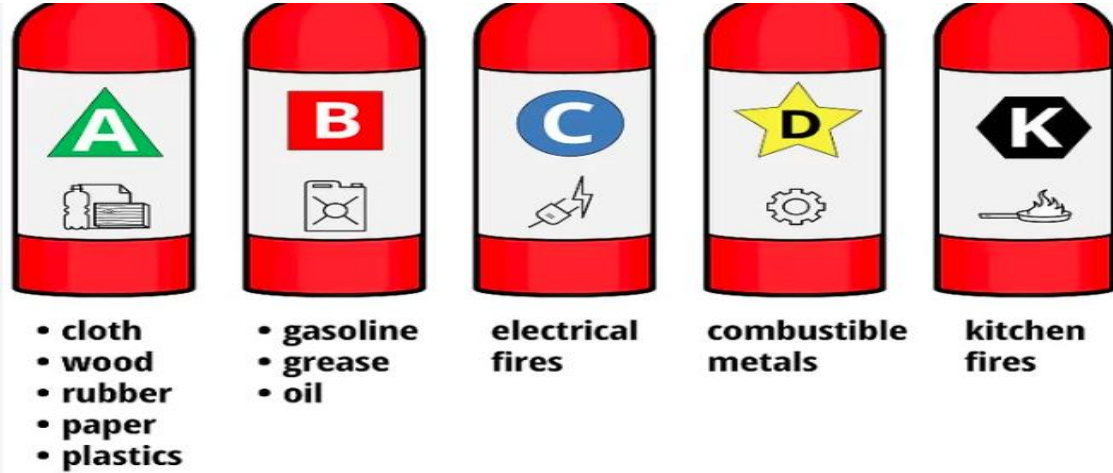

Figure 3.7: Fire extinguishers.[28]

✓ CO2 fire extinguishing system SGJ21/23 LP CO2 system:



Figure 3.8: CO2 fire extinguishing.[3]

✓ Fire extinguishing system Argonite system 11SGK31:



Figure 3.9: Argonite system 11SGK31.[29]

✓ Fire detection system cye10:



Figure 3.10: Detection system.[3]



- ✓ **Firefighting system sprinkler system sge27 GT:**

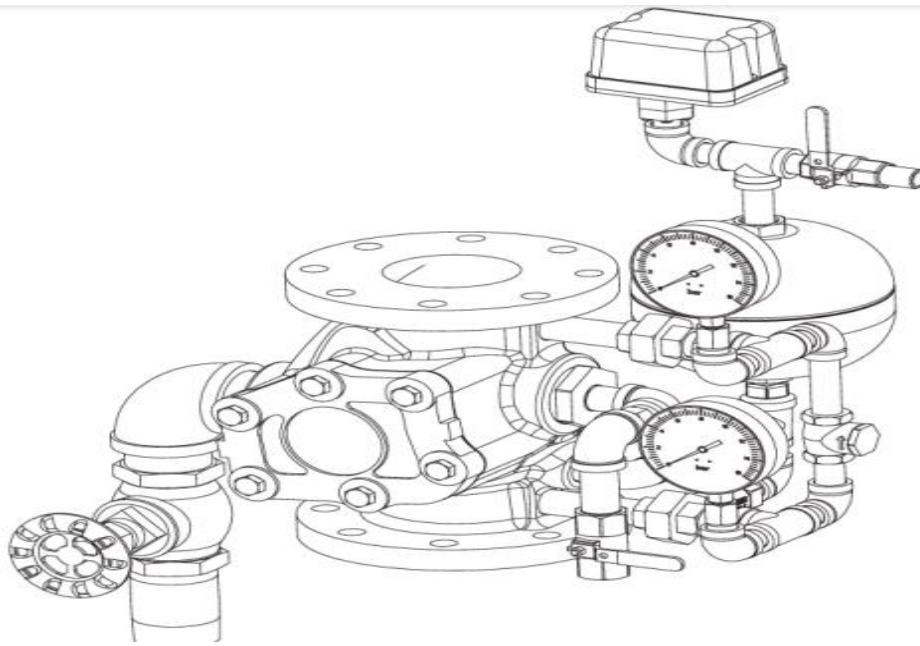

**Figure 3.11: System sprinkler.[3]**

### III.2. Electrical Risk

Electrical risk refers to the potential for harm or injury due to electrical hazards. These hazards can arise from various sources and situations involving electrical equipment, wiring, or power systems. The risks can range from minor shocks to severe burns, electrocution, fires, and explosions.

#### ❖ Causes

- Poorly installed or deteriorated wiring can lead to short circuits, overheating, and fires.
- Exceeding the capacity of electrical circuits can cause overheating and potential fire hazards.
- Lack of proper grounding can result in electrical shocks and increased risk of fire.
- Exposed wires and components can lead to accidental contact and electric shocks.
- Electrical equipment in wet or damp environments can lead to increased risk of electrical shocks.
- L'utilisation d'appareils électriques ou d'outils endommagés peut présenter de graves dangers.
- Lack of proper training for personnel handling electrical equipment can result in improper usage and increased risk of accidents.

#### ❖ Preventive Measures

- Conduct regular checks and maintenance of electrical systems and equipment to identify and correct potential hazards.
- Ensure electrical systems and wiring is installed by qualified professionals in accordance with relevant codes and standards.

- Install protective devices such as circuit breakers, fuses, and Ground Fault Circuit Interrupters (GFCIs) to prevent overloads and short circuits.
- Ensure all electrical systems are properly grounded to prevent electrical shocks and fire hazards.
- Provide comprehensive training for personnel on safe handling and operation of electrical equipment.
- Use of Personal Protective Equipment (PPE)
- Raise awareness of electrical risks and promote safety culture through regular safety briefings and educational programmes.



**Figure 3.12: Various Types of electrical PPE.[30]**

### III.3. Explosion risk

Explosion risk refers to the potential for a sudden and violent release of energy causing a rapid increase in volume and release of gases, which can result in significant damage, injury, or death. Explosions can occur in various settings, including industrial, commercial, and residential environments, often due to the presence of flammable gases, dust, or volatile substances.

#### ❖ Causes

- Accumulation of flammable gases or vapors in an enclosed space can lead to an explosion if ignited.
- Fine particles of combustible materials (e.g., wood, grain) suspended in the air can cause dust explosions when ignited.
- Improper handling or mixing of reactive chemicals can lead to explosive reactions.
- Failure of pressurized equipment, such as boilers or gas cylinders, can result in explosions due to sudden release of pressure.
- Activities such as welding, cutting, or grinding can produce sparks or high temperatures that ignite explosive atmospheres.
- Faulty or unprotected electrical equipment can produce sparks that ignite explosive mixtures.
- Storing flammable materials inappropriately or in unsuitable containers can increase the risk of explosion.

- Inadequate training, negligence, or mistakes by personnel can lead to conditions that cause explosions.

#### ❖ Preventive Measures

- Hot work permits.
- Clearly mark hazardous areas and provide adequate warning signs to alert personnel to the presence of explosive risks.
- Develop and regularly update emergency response plans.
- Provide comprehensive training for employees on explosion risks, safety procedures, and emergency response plans.
- Store flammable and reactive materials in appropriate containers and locations to minimize the risk of accidental ignition.
- Ensure proper ventilation in areas where flammable gases, vapors, or dusts are present to prevent accumulation to explosive levels.
- Regular inspections and maintenance.



**Figure 3.13: Cutation risk of explosion.[31]**

#### III.4. Chemical Risk

Chemical risk refers to the potential for harm or injury due to exposure to hazardous chemicals. These risks can arise from the use, handling, storage, and disposal of chemicals in various environments, including industrial, laboratory, and domestic settings. Chemical risks can result in acute or chronic health effects, environmental damage, fires, explosions, and contamination.

#### ❖ Causes

- Corrosive chemicals can damage skin, eyes, respiratory tract, and materials, leading to burns and material degradation.
- Exposure to toxic chemicals can cause immediate or long-term health effects, including poisoning, respiratory issues, and organ damage.
- Reactive chemicals can undergo dangerous reactions when exposed to heat, light, water, or other substances, leading to fires, explosions, or toxic releases.
- Incorrect handling or use of chemicals.

- Improper storage conditions, such as incompatible chemicals stored together or inadequate containment.
- Failure to use appropriate PPE.
- Incorrect disposal of chemical waste.
- Mistakes made by personnel due to lack of training, awareness, or negligence.

#### ❖ Preventive Measures

- Store chemicals according to their hazard class, using appropriate containers and storage conditions. Keep incompatible chemicals separated to prevent dangerous reactions.
- Provide and enforce the use of appropriate PPE, such as gloves, goggles, aprons, and respirators, based on the chemicals being handled.
- The safety data sheet (SDS)
- Provide comprehensive training for employees on chemical hazards.
- Ensure adequate ventilation in areas where chemicals are used or stored to prevent the buildup of hazardous vapors and gases.
- Waste Management.
- Regular Inspections and Maintenance.
- Develop and regularly update emergency response plans.



**Figure 3.14: Chemical product.[32]**

According to this investigation that we conducted at SKT, these were some of the basic tasks that they always do, so we conducted a simple risk assessment and also extracted the major risks, and how to prevent it.

**IV. FMECA method****IV.1. System studied :**

We have chosen to study the hazards of static electrical installations in the SKT power plant.

**IV.2. Functional analysis of electrical installation:**

Figure 3.15: Functional analysis of electrical installation.

**IV.3. Criteria for choosing the FMECA method**

There is no right or wrong method, and each method has its own advantages and disadvantages. As a result, the specific method is generally more or less suited to the material environment and the desired goal.

During our internship at the SKT power plant on substation electrical installations, we found that several electrical components can be the cause of an electrical accident, and we consider FMECA to be the most appropriate and precise method for this case, as it enables failures to be classified and prioritized according to certain criteria (probability of occurrence, detection, severity). The results of this analysis are the priority actions required to significantly reduce the risk of potential failures.

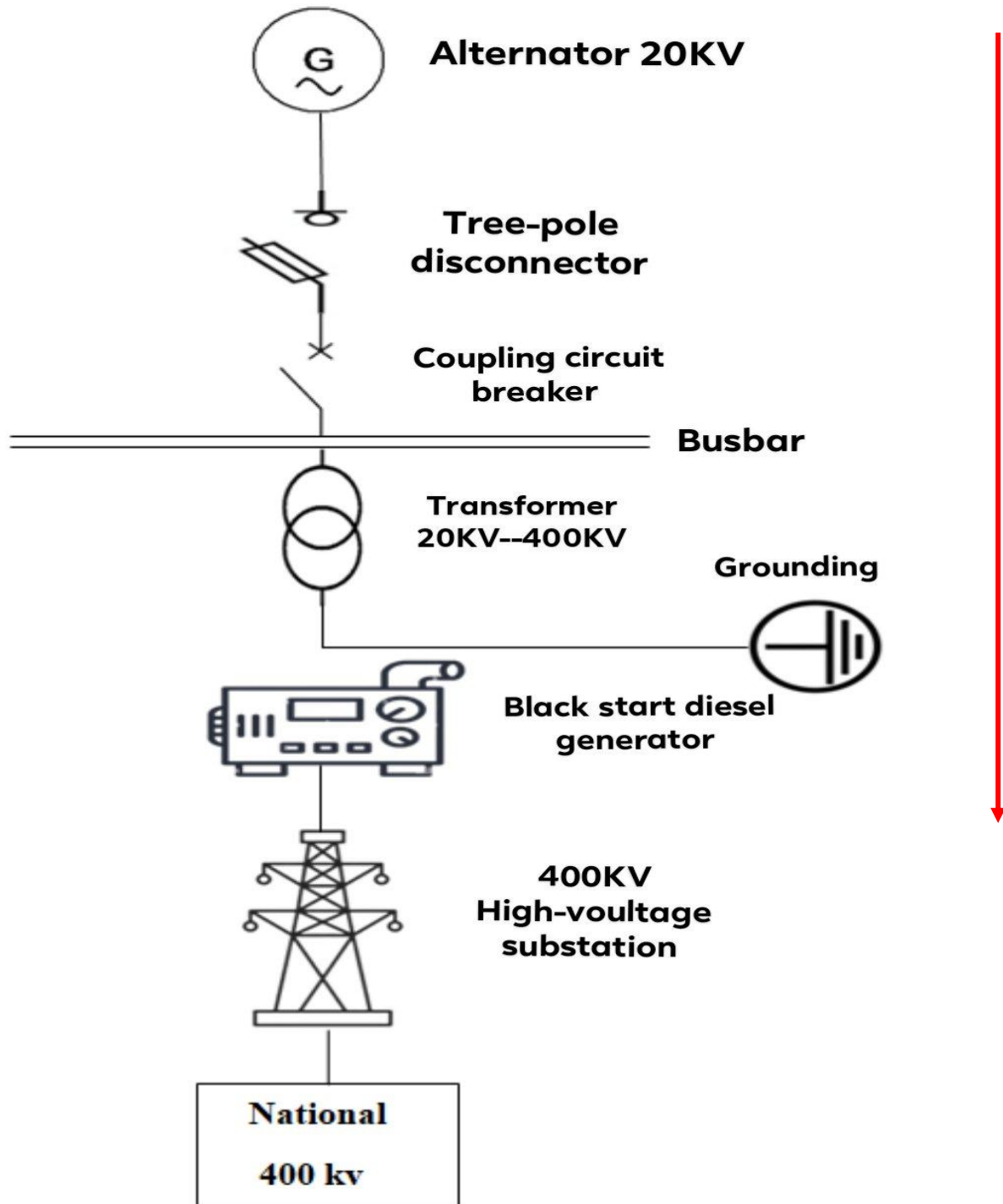
**IV.4. Criticality study**

This is the quantitative part of the study:

- The severity of the effects associated with each failure mode;
- The frequency of occurrence of each failure mode - derived from the causes;
- The probability of not detecting the failure mode (known as the 'D' factor) Criticality is then defined as the product of the three factors ;

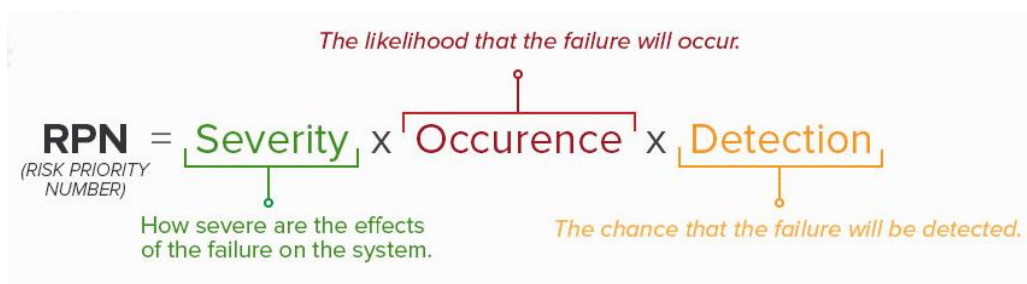

**Figure 3.16: Risk Priority Number (RPN).[33]**

- **Risk Matrix :**

**Table 3.1: Criticality assessment.**

S \ F	1 Insignificant	2 Minor	3 Significant	4 Major	5 severe
Almost Certain 5	Acceptable	Indeserable	Unacceptable	Unacceptable	Unacceptable
Likely 4	Acceptable	Acceptable	Indeserable	Unacceptable	Unacceptable
Moderate 3	Negligible	Acceptable	Acceptable	Indeserable	Unacceptable
Unlikely 2	Negligible	Negligible	Acceptable	Acceptable	Indeserable
Rare 1	Negligible	Negligible	Negligible	Acceptable	Acceptable

- **Detectability (D):**

This reflects the ability to identify or predict the failure before it manifests itself in an operational scenario. The aim here is to evaluate how robust the current controls are in catching or preventing the failure. A score between 1 and 4 is assigned, with 1 denoting an extremely high likelihood of detection and 4 representing a situation where the failure is almost certain to go undetected.

**Table 3.2: Assessment of non-detection.**

D Factor		Failure detection
Note	Detection level	
1	Negligible	No further action may be needed and maintaining control measures is encouraged.
2	Acceptable	May be considered for further analysis.
3	Indeserable	Must be reviewed in a timely manner to carry out improvement strategies.
4	Unacceptable	Must implement cease in activities and endorse for immediate action.

- **Frequency of occurrence (F):**

This gauges the likelihood of the failure mode occurring. It takes into consideration the frequency at which the problem is likely to transpire during the life of the system, product, or process. The team assigns a score from 1 to 5, where 1 suggests a rare event and 5 signifies a nearly certain occurrence.

**Table 3.3: Assessment of Frequency.**

F Factor		Frequency of failure
Note	Frequency level	
1	Rare	Unlikely to happen and/or have minor or negligible consequences.
2	Unlikely	Possible to happen and/or to have moderate consequences.
3	Moderate	Likely to happen and/or to have serious consequences.
4	Likely	Almost sure to happen and/or to have major consequences.
5	Frequent	Sure to happen and/or have major consequences.

- **Severity (S):**

Severity (or Gravity) this measures the gravity of the potential impact on the customer or end-user if the failure were to occur. It could be a minor inconvenience, a significant disruption, or a serious safety issue. Each failure mode is scored on a scale from 1 to 5, with 1 indicating a negligible effect and 5 indicating a catastrophic or critical outcome.

**Table 3.4: Assessment of Severity.**

Factor (S)		Severity of failure
Note	severity level	
1	Insignificant	Won't cause serious injuries or illnesses.
2	Minor	Can cause injuries or illnesses, only to a mild extent.
3	Significant	Can cause injuries or illnesses that may require medical attention but limited treatment.
4	Major	Can cause irreversible injuries or illnesses that require constant medical attention.
5	Catastrophic	Can result in fatality.

- **Classification of risk zones :**

**Table 3.5: Criticality assessment.**

Risk	Limit
Acceptable risk.	$C \leq 12$
Acceptable risk under control.	$12 < C \leq 15$
Undesirable risk.	$15 < C \leq 27$
Unacceptable risk.	$27 < C$



## V. Application of FMECA

Table 3.6: Failure Mode Effects and Criticality Analysis

						Nominal indices				Action Corrective	Final indices			
Element	Function	Failure Mode	Causes	Effects on the system	Detection	F	S	D	R		F	S	D	R
Alternator 20 kv	Transformation Of mechanical energy into electrical energy	Faulty ventilation	The clogging of the entrance gates	-Over heating -will reduce -service life	-temperatur detector -visual inspection	3	3	3	27	Maintenance and periodic inspection of air inlet and exhaust grilles	2	2	3	12
		Mechanical failure	clashing operation of ball bearings	Nuisances	Visual inspection	2	3	3	18	replacement of bearings and periodic inspection	2	2	3	12

## Interpretation

- After this study we concluded that the cause of failure with the greatest criticality is faulty ventilation.
- Corrective measure may include maintenance, periodic inspection of air inlet and exhaust grilles.

Table 3.7: Failure Mode Effects and Criticality Analysis

						Nominal indices				Action Corrective	Final indices			
Element	Function	Failure Mode	causes	Effects on the system	Detection	F	S	D	R		F	S	D	R
Three-pole disconnecter	open and close the circuit	Don't open	mechanical blockage	-fuse not protected when changing it - circuit fails with open block	during the maneuver	2	4	2	16	periodic maintenance	1	4	2	8
		-Don't close -the electric arc	power cut	power failure	during the maneuver	3	4	2	24	- periodic maintenance -change the insulating elements by arc conductive elements - empowerment. -fuse change	2	4	2	16

### Interpretation

- After this study, we concluded that the cause of failure with the greatest criticality is the electric arc.
- The corrective measures implemented, including periodic maintenance of three-pole disconnecter, change of insulating elements by arc conductors' elements, empowerment and fuse change.

Table 3.8: Failure Mode Effects and Criticality Analysis

						Nominal indices				Action Corrective	Final indices			
Element	Function	Failure Mode	causes	Effects on the system	Detection	F	S	D	R		F	S	D	R
coupling circuit breaker	- cut off the circuit in case of electrical overload or incident - overload, short circuit and surge protection	no response	- mechanical cause - magnetic cause - oil disturbance - not current excessive	-Explosion -No fire system projection - Power failure in the event of a short-circuit is not triggered	temperature detector	3	3	3	27	periodic maintenance	2	3	3	18

### Interpretation

- After this study it was concluded that the causes of failure are mechanical, magnetic, oil disturbance or not excessive current.
- The corrective actions implemented may include the implementation of a standard preventive maintenance program

Table 3.9: Failure Mode Effects and Criticality Analysis

						Nominal indices				Action Corrective	Final indices			
Element	Function	Failure Mode	causes	Effects on the system	Detection	F	S	D	R		F	S	D	R
busbar	- branch the lines between them	the rapprochement between the lines	- warming - cooling - manufacturing problem	transformer start-up overvoltage temperature	temperature detector	3	3	3	27	periodic maintenance	2	2	3	12
		structural failure	- mechanical - magnetic	- on heating	temperature detector	3	3	3	27	Maintenance and periodic inspection.	2	3	2	12

### Interpretation

- After this study, it was concluded that the causes of failure are warming, cooling, manufacturing problem, mechanical and magnetic.
- The corrective actions implemented may include the implementation of a Maintenance and periodic inspection of busbar.

Table 3.10: Failure Mode Effects and Criticality Analysis

Element	Function	Failure Mode	causes	Effects on the system	Detection	Nominal indices				Action Corrective	Final indices			
						F	S	D	R		F	S	D	R
transformer (20kv-400kv)	- transforms the supply voltage 20kv-400kv	Absorbed current required during Operation.	Short-circuit in stator.	Explosion temperature	Smoke detectors.	3	4	4	48	Check insulation between phases and stator.	2	4	3	24
		ventilation failure	Magnetic cause	On heating.	-Temperature detector -Visual inspection	3	3	2	18	Mechanical maintenance	2	3	2	12
		Oil leak	Degraded joints.	On heating.	-Temperature detector -Visual inspection	3	3	2	18	-Mechanical Maintenance -periodic inspection.	2	3	2	12

### Interpretation

- After this study, it was concluded that the cause of failure with the highest criticality is the absorbed current required during operation.
- Corrective measures may include periodic checks and insulation between phases and stator.

Table 3.11: Failure Mode Effects and Criticality Analysis

						Nominal indices				Action Corrective	Final indices			
Element	Function	Failure Mode	causes	Effects on the system	Detection	F	S	D	R		F	S	D	R
Grounding	Absorption of static charges to earth	Cable breakage	-Lack of control -Bad contact -Bad tightening, mechanical shock	fire	Detection device or Visual	2	4	2	16	Periodic inspection.	2	2	2	8

### Interpretation

- After this study, it was concluded that the cause of failure with the highest criticality is the lack of control.
- Corrective measures may include the periodic inspection.

Table 3.12: Failure Mode Effects and Criticality Analysis

						Nominal indices				Action Corrective	Final indices			
Element	Function	Failure Mode	causes	Effects on the system	Detection	F	S	D	R		F	S	D	R
black start diesel generator 6.6 kv	Main transformer power supply.	motor does not start	The network is not owered.	fire	smoke detector, temperature detector	3	4	2	24	check mains voltage during operation,	2	3	2	12
		fuse does not work.	Human error.	thermal effect	smoke detector, temperature detector	2	4	2	16	change fuse	1	3	2	6
		Generator does not produce Current.	-Circuit, - indicator cuts out - mechanical cause	Fire	smoke detector, temperature detector	3	3	2	18	Change alternator.	2	3	2	12

### Interpretation

- After this study, it was concluded that the cause of failure with the highest criticality is the network is not energized
- Corrective measures may include the check mains voltage during operation.

Table 3.13: Failure Mode Effects and Criticality Analysis

Element	Function	Failure Mode	causes	Effects on the system	Detection	Nominal indices				Action Corrective	Final indices			
						F	S	D	R		F	S	D	R
400kv high-voltage substation	power plant start-up	three-phase fault	short circuit between three ungrounded phases.	Fire overheating,	-measured voltage and current -temperature detection -smoke detection	3	4	3	36	periodic check	2	2	3	12
		two-phase fault	-short circuit of two phases or one phase is neutral with/without Earthing.											
		single-phase fault	-short circuit between one phase and earth or one phase is neutral.											
		insulation fault.	Damage to cable protection.	fire	-Smoke detector - temperature detector	3	3	3	27					

**Interpretation**

- After this study, it was concluded that the cause of failure with the highest criticality is the three-phase fault, two-phase fault and single-phase fault
- Corrective measures may include the periodic check.



**VI. Results of application of FMECA****VI.1. Before application:****Table 3.14: Results of application of FMECA before application.**

Element	Failure mode	Criticality
Alternator 20 kv	Faulty ventilation.	27
	Mechanical failure.	18
Three-pole disconnecter	Don't open.	16
	Don't close.	24
Coupling circuit breaker	No response.	27
Busbar	The rapprochement between the lines.	27
	Structural failure.	27
Transformer (20kv-400kv)	Absorbed current required during Operation.	48
	Ventilation failure.	18
	Oil leak.	18
Grounding	Cable breakage.	16
Black start diesel generator 6.6 kv	Motor does not start.	24
	Fuse does not work.	16
	Generator does not produce Current.	18
400kv high voltage substation	Three-phase fault.	36
	Two-phase fault.	36
	Single-phase fault.	36
	Insulation fault.	27

 Undesirable risk

 Unacceptable risk

**V.2.After application:****Table 3.15: Results of application of FMECA after application.**

Element	Failure mode	Criticality
Alternator 20 kv	Faulty ventilation.	12
	Mechanical failure.	12
Three-pole disconnecter	Don't open.	8
	Don't close.	16
Coupling circuit breaker	No response.	18
Busbar	The rapprochement between the lines.	12
	Structural failure.	12
Transformer (20kv-400kv)	Absorbed current required during Operation.	24
	Ventilation failure.	12
	Oil leak.	12
Grounding	Cable breakage.	8
Black start diesel generator 6.6 kv	Motor does not start.	12
	Fuse does not work.	6
	Generator does not produce Current.	12
400kv high voltage substation	Three-phase fault.	12
	Two-phase fault.	12
	Single-phase fault.	12
	Insulation fault.	12

 Acceptable risk

 Undesirable risk

❖ **Criticality statistics graph before FMECA:****Figure 3.17: Criticality before FMECA.**

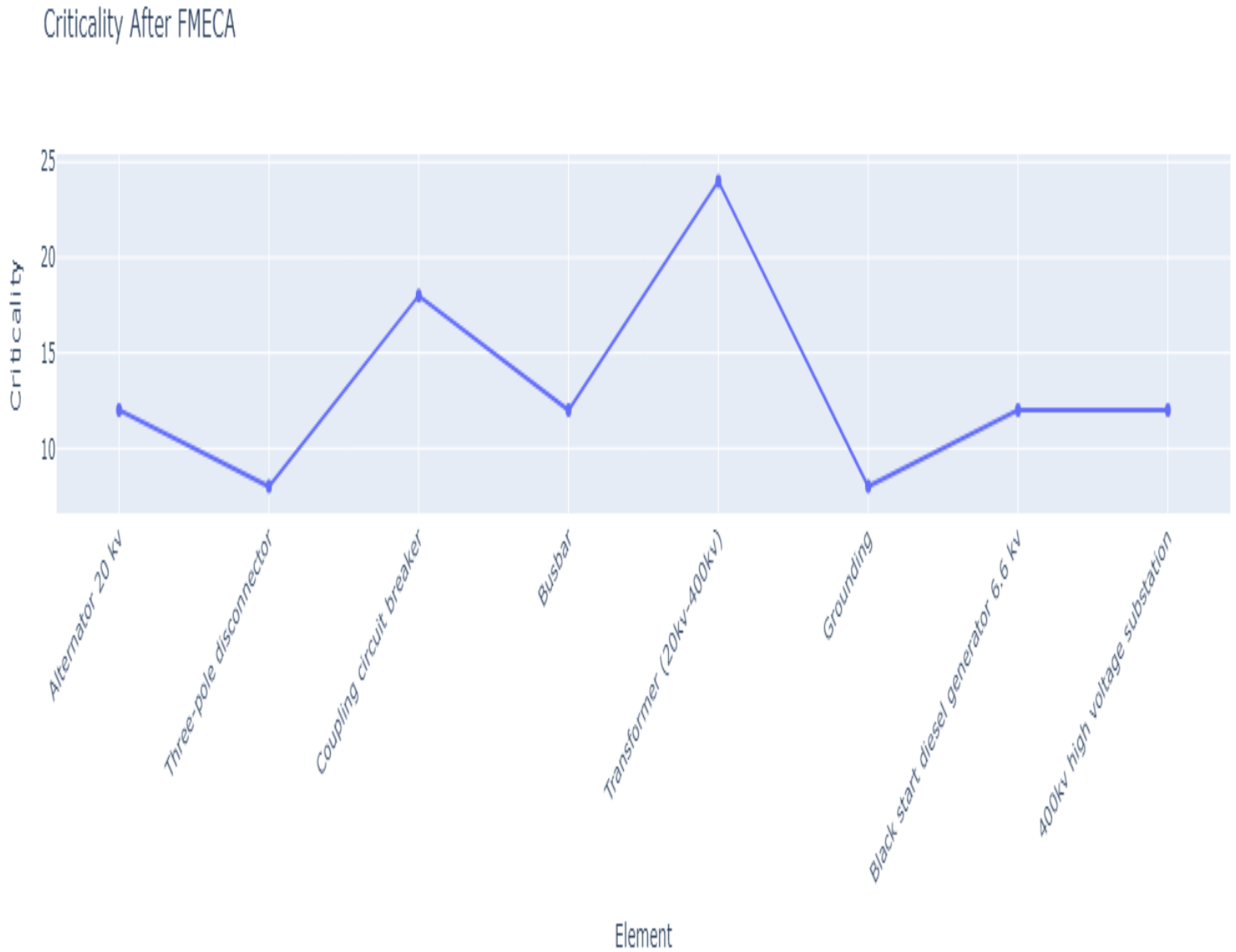
❖ **Criticality statistics graph after FMECA:****Figure 3.18: Criticality after FMECA.**

❖ **Histogram comparing criticality statistics graph before and after the implementation FMECA:**



**Figure 3.19: Histogram comparing criticality statistics graph before and after the implementation FMECA**

Once the actions are performed, the criticality is recalculated. All these actions thus make it possible to reduce the frequency of failures while optimizing the frequency of preventive interventions.

At the end of this study, the following recommendations can be made:

Systematic maintenance instructions must be followed, such as replacing defective parts at the intervals recommended by the manufacturer.

- Repeat the FMECA study systematically.
- Train maintenance department personnel in FMECA.
- Keep a safety stock of 1st necessity spare parts.

→ Train maintenance technicians on equipment to facilitate anomaly detection.

At the end of this study, we can support the idea of the Dashboard for making it easier for us to read and keep track of these tables.

### **Conclusion**

In this chapter, we have assessed the existing hazards in SKT Central Unit and proposed appropriate preventive measures to reduce the likelihood and severity of these hazards. The FMECA method aims to analyze predictive failures and hazards on equipment or systems to enhance their safety and reliability, thereby reducing failure rates and defect repair times.

Our assessments within SKT's centralized unit, along with subsequent analyses, are in line with theoretical principles. This is evidenced by our ability to identify the root causes of nonconformities and operational defects. The implementation of the Risk Management Dashboard has played a critical role in facilitating these assessments by providing real-time data and insights. Risk prevention is the key to avoiding the recurrence of incidents. In addition, integrating incident analysis with advanced methods and collaborative workgroups helps ensure a thorough understanding of responsibilities.



---

# CHAPTER 04

## **AUTOMATED DASHBOARD FOR SKT**

---

## **I. Introduction**

Over the past few months, SKT has meticulously recorded the various risks associated with its operations, collecting important data on their occurrence, impact and management strategies. This valuable information has been organized into a comprehensive table, providing a detailed overview of the risks we face. However, to improve our ability to effectively analyze, monitor and respond to these risks, we took the next step by transforming this data into an interactive dashboard using Python Language. This dashboard enables real-time monitoring, improved decision-making, enhanced communication, trend analysis and greater efficiency and accountability in risk management.

## **II. Risk assessment.**

With this dispersed information, we assessed the risks that the company has recorded in recent months of year 2024 and we put them in the form of a table as follows :



**Table 3.16: Risk assessment.**

Risk Description	Risk Type	Likelihood	Cause of Risk	Consequence of Risk	Severity	Impact on Cost	Impact on Time	Impact on Quality	Impact on Safety	Overall Risk Exposure
Delayed inspection leading to pump failure	Negative	Likely	Lack of regular maintenance schedule or oversight.	Pump malfunction or breakdown, potentially leading to operational downtime, loss of production, and costly repairs or replacements.	Major	High	High	High	High	High
Purger failure causing operational issues	Negative	Moderate	Malfunctioning or improperly maintained purging system.	Operational disruptions, reduced efficiency in gas compression or purification processes, and potential safety risks if gases are not properly managed.	Moderate	Moderate	Moderate	Moderate	Moderate	Moderate
Operational inefficiency	Negative	Moderate	Ineffective operational procedures, outdated equipment, or inadequate training.	Reduced productivity, higher operational costs, and potential strain on resources	Moderate	Moderate	High	High	High	High

				due to inefficient use of energy or materials						
Electrical panel collapse	Negative	Likely	Overloading, poor maintenance of electrical systems, or electrical faults.	Power outage, equipment damage, safety hazards	Major	High	High	High	High	High
Motor damage	Negative	Moderate	Overheating, mechanical wear, lack of lubrication, or electrical issues.	Motor failure, operational downtime, increased maintenance costs, and potential impact on production output.	Major	High	Moderate	Low	Low	Moderate
Poor lighting around the gas compressor skid	Negative	Unlikely	Inadequate lighting installation or maintenance.	Increased risk of accidents or injuries, reduced visibility leading to operational errors, and potential safety violations.	significant	Low	Moderate	Moderate	Low	Low
Oil spills near the pump	Negative	Moderate	Leaks from pump seals, improper handling of lubricants, or equipment failure.	Environmental contamination	Major	Moderate	Moderate	Moderate	Moderate	Moderate
Improperly reassembled instruments	Negative	Unlikely	Errors during maintenance or repair activities.	Incorrect readings or measurements, potential equipment malfunction	significant	Moderate	Moderate	Moderate	Moderate	Moderate
Incorrect disassembly of instruments	Negative	Unlikely	Lack of training or procedural errors during maintenance.	Damage to instruments, operational disruptions	significant	Low	High	Moderate	High	High

Incorrect disconnection	Negative	Unlikely	Human error during equipment maintenance or modification.	Electrical hazards, equipment damage, operational interruptions, and potential safety risks to personnel.	significant	High	Moderate	Moderate	High	High
A detached air temperature gauge	Negative	Unlikely	Mechanical failure, improper installation, or maintenance oversight.	inaccurate temperature readings, potential operational inefficiencies, and difficulty in monitoring critical process parameters.	Minor	Low	Moderate	Low	Moderate	Moderate
Regular demineralized water replenishment	Negative	Unlikely	Inadequate monitoring or scheduling of water quality maintenance.	Reduced efficiency of water-dependent equipment, potential corrosion or scaling issues	significant	Moderate	Moderate	High	High	High
Steam leaks	Negative	Moderate	Faulty seals, worn-out gaskets, or excessive pressure.	Energy loss, reduced system efficiency	significant	Moderate	Moderate	Moderate	Moderate	Moderate

Having analyzed these risks, we need to turn them into a dashboard that provides a clear visual representation of risk levels, helping to prioritize risks based on their potential impact and likelihood of occurrence, using a python language:

**III. Dashboard:**

**❖ Risk types**



**Figure 4.1: Risk type.**

**❖ Risk levels in camembert:**

Contingency Distribution

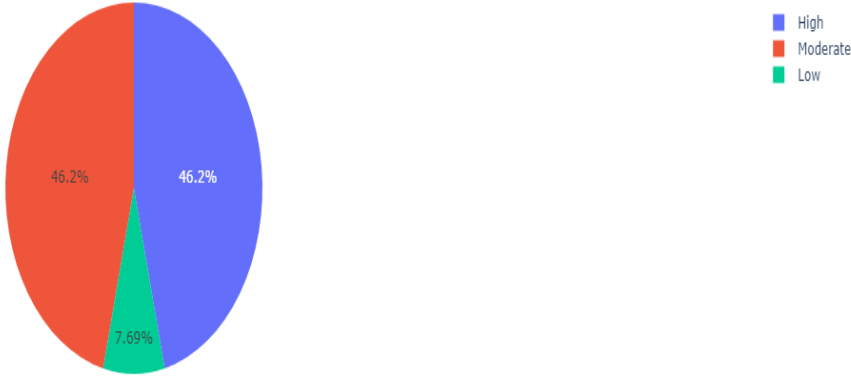

**Figure 4.2: Risk levels 1.**

❖ Risk levels in graph:

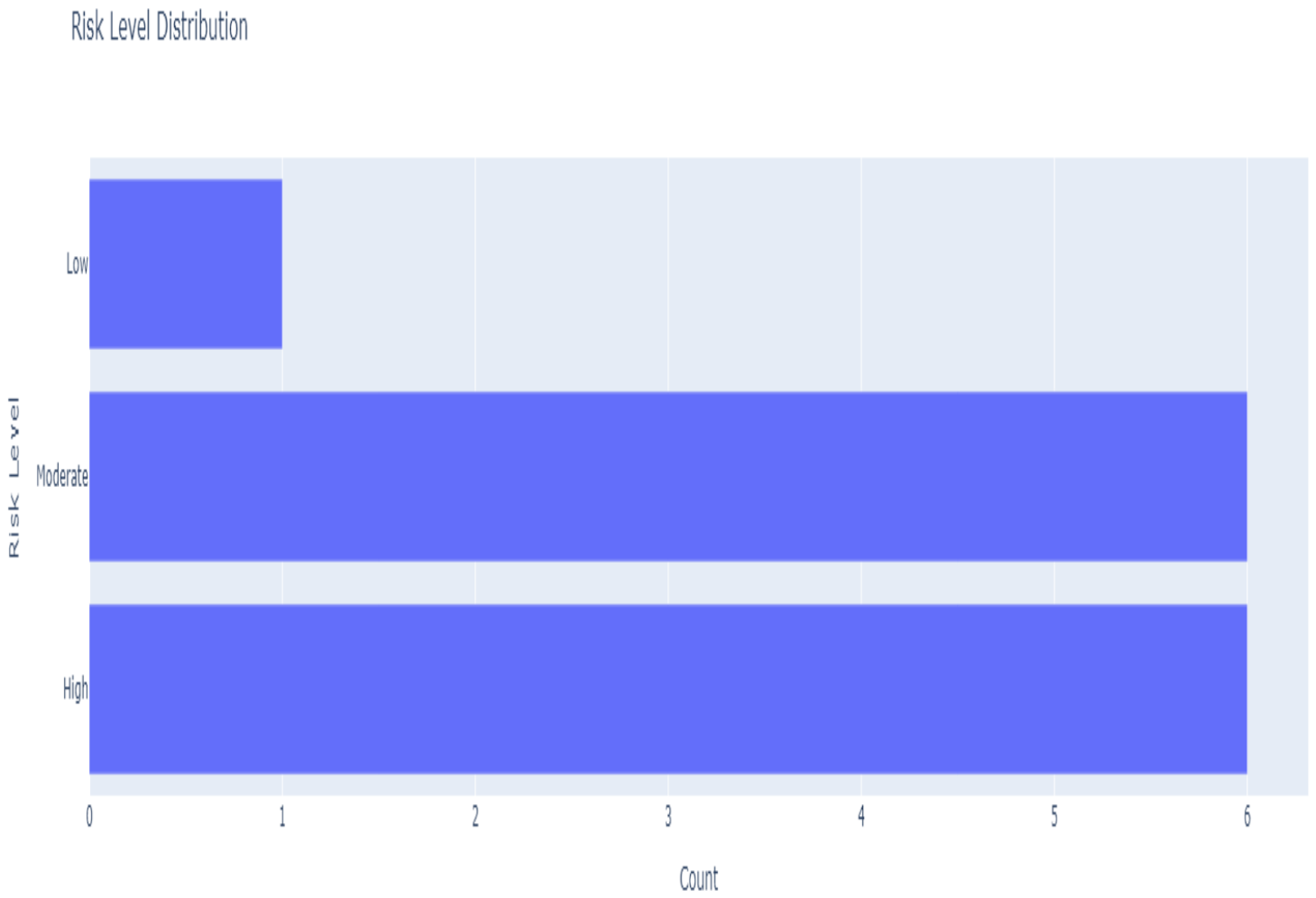
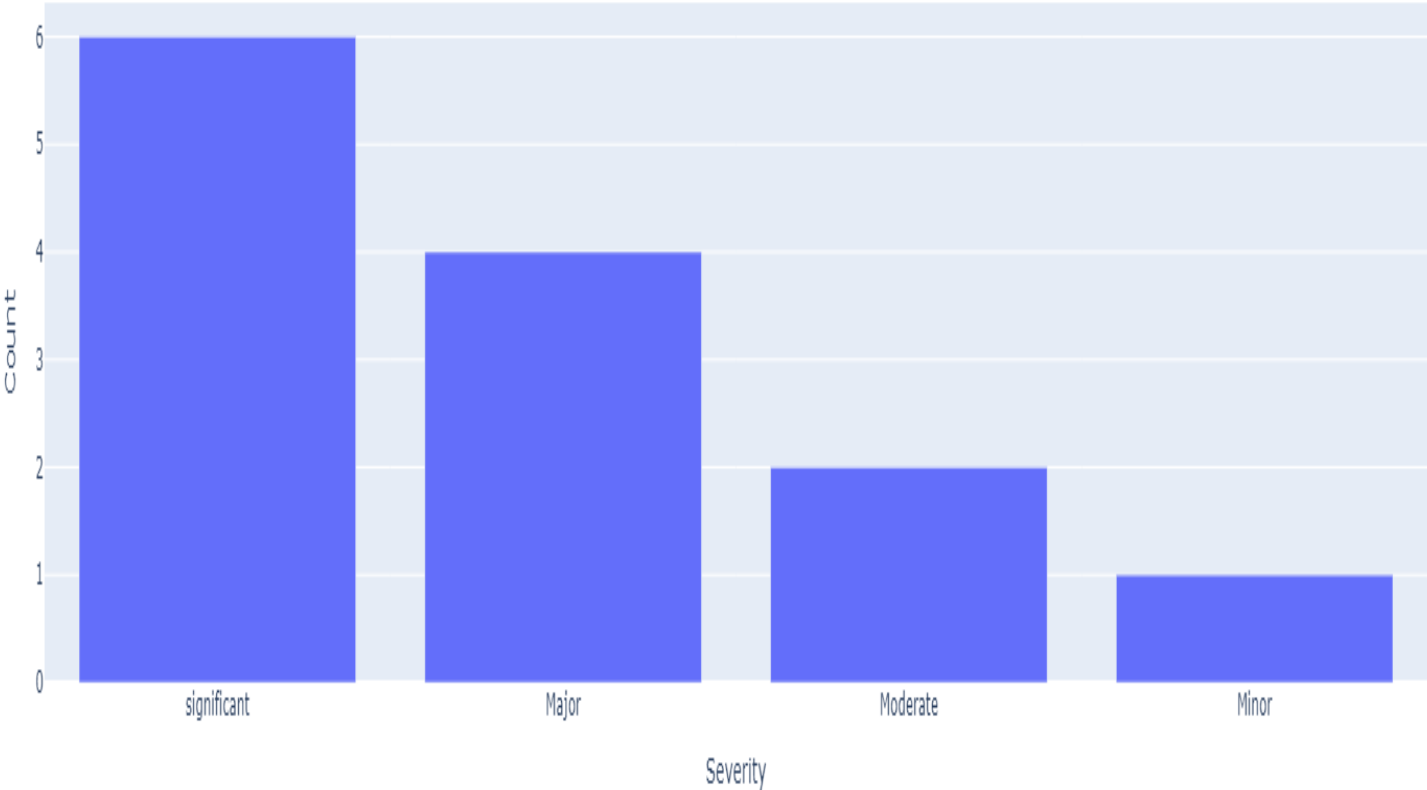

Figure 4.3: Risk levels 2.

❖ **Severity type :**

Severity Type Distribution



**Figure 4.4: Severity type.**

❖ **likelehood type:**

Likelihood Type Distribution

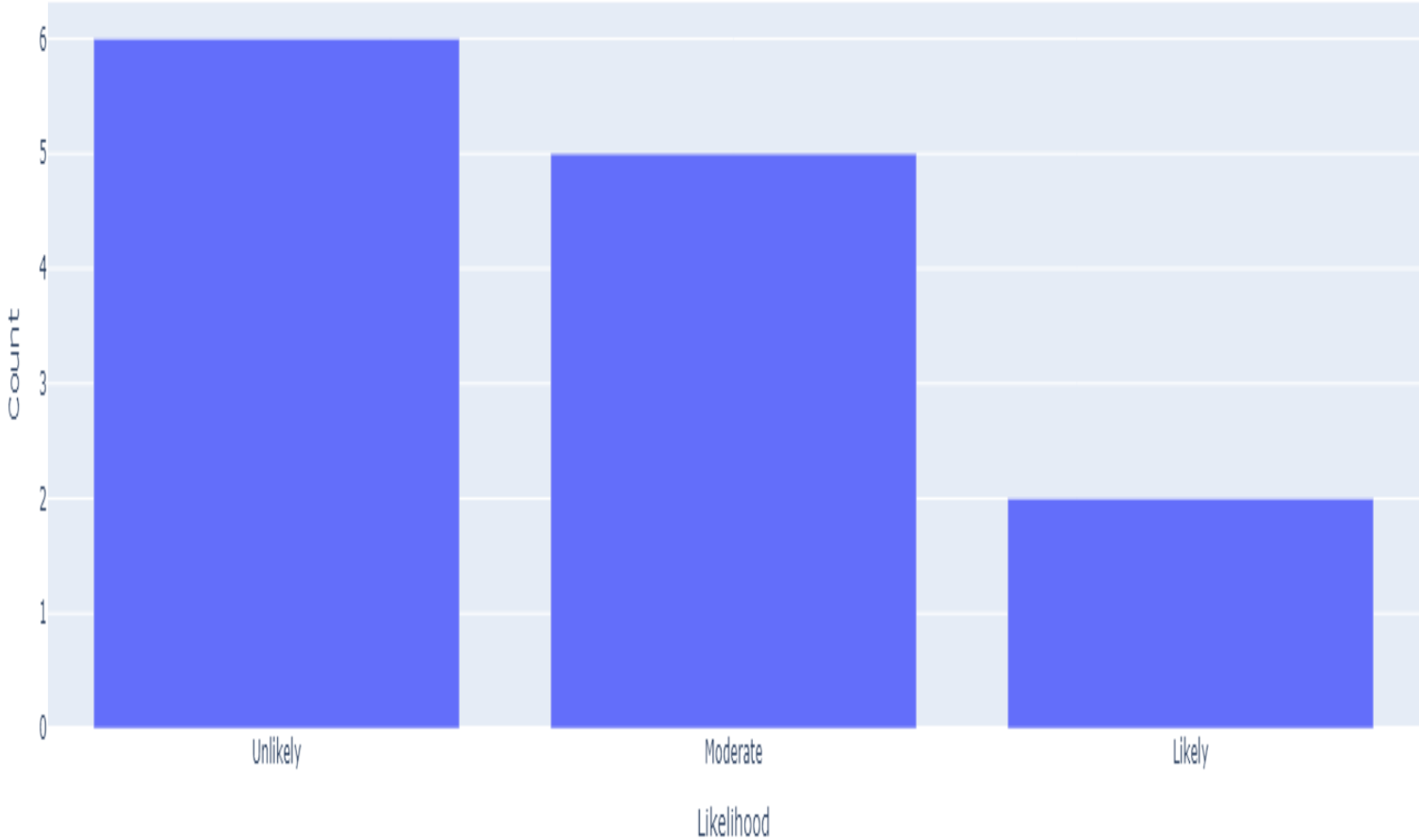

**Figure 4.5: likelihood type.**

## **VI. Conclusion**

In summary, our company's diligent recording of various operational risks has provided us with a foundational understanding of the threats we face. By transforming this information into an interactive dashboard, we have significantly enhanced our ability to monitor and respond to risks in real-time. This tool not only facilitates better decision-making and communication but also allows for detailed trend analysis and increased efficiency in risk management processes.

The implementation of a risk management dashboard is proving to be a valuable asset in our industry, helping us to maintain operational resilience and improve overall safety. Moving forward, we are committed to further developing our project by incorporating more advanced analytical features and expanding the scope of data collected. This ongoing development will ensure that our risk management practices continue to evolve, keeping pace with the dynamic challenges of our industry.



### **General conclusion**

The creation and implementation of an automated dashboard for SKT TERGA represents a pivotal step forward in workplace safety and risk management. By leveraging the Failure Modes, Effects, and Criticality Analysis (FMECA) method, the project systematically identifies, assesses, and prioritizes risks associated with electric equipment, providing a structured and thorough approach to risk management.

The dashboard's visual representation of risk levels allows for the clear communication of critical risks, facilitating informed decision-making among stakeholders. Its real-time monitoring capabilities ensure continuous assessment and timely updates of risks, enabling a proactive and dynamic approach to hazard mitigation.

This project underscores the importance of proper risk management in preventing workplace accidents and work-related illnesses. By focusing on the most significant risks and providing actionable insights, the dashboard enhances the ability of SKT TERGA to maintain a safer and healthier work environment.

Through the implementation of this automated dashboard, SKT TERGA can better anticipate and address potential hazards, thereby reducing the incidence of accidents and occupational illnesses. The successful application of the FMECA method in this context demonstrates its effectiveness in managing complex risk scenarios, particularly in the domain of electrical safety.

Overall, this project highlights the critical role of innovative risk management tools in promoting workplace safety and health. The insights and methodologies developed herein provide a valuable framework for future initiatives aimed at mitigating risks and enhancing the well-being of employees in various industrial settings.

## BIBLIOGRAPHY

- [1] Présentation de la société de SONELGAZ n.d.
- [2] Sonelgaz n.d. <https://www.sonelgaz.dz/fr/category/historique> (accessed May 29, 2024).
- [3] Documentation du principe fonctionnement générale du SKT n.d.
- [4] Material types used in different sections in an Alstom gas turbine... | Download Scientific Diagram n.d. [https://www.researchgate.net/figure/Material-types-used-in-different-sections-in-an-Alstom-gas-turbine-engine-Re-drawn-from\\_fig3\\_326226200](https://www.researchgate.net/figure/Material-types-used-in-different-sections-in-an-Alstom-gas-turbine-engine-Re-drawn-from_fig3_326226200) (accessed June 16, 2024).
- [5] Maintenance Strategies for Steam Turbines n.d. <https://www.linkedin.com/pulse/maintenance-strategies-steam-turbines-engineering-updates> (accessed June 16, 2024).
- [6] gestion-risque- le gouvernement du grand duche de luxembourg ministère de la sante\_version7\2013.
  
- [7] Les risques industriels : types, effets et gestion. Boplan 2022. <https://www.boplan.com/fr/les-risques-industriels-types-effets-et-gestion> (accessed April 18, 2024).
- [8] TWI Middle East FZ-LLC, 2012. Principles of Health & Safety Management. NEBOSH International Diploma, Unit IA4..
- [9] Rommel Mangilit- Risk Assessment & Job Safety Analysis 21\07\2012
- [10] DPM. 7 Steps in Privacy Risk Management. Data Priv Manag 2022. <https://dataprivacymanager.net/7-steps-and-elements-of-privacy-risk-management/> (accessed April 25, 2024).
  
- [11] Picovschi A. Dommage corporel et risque industriel : quelle indemnisation ? - Droit des affaires - Cabinet Avocats Picovschi. Avocats Picovschi 2024. <https://www.avocats-picovschi.com/> (accessed May 24, 2024).
  
- [12] Managing risks and risk assessment at work – Overview -HSE <https://www.hse.gov.uk/index.htm>
- [13] TWI Middle East FZ-LLC, 2012. Principles of Health & Safety Management. NEBOSH International Diploma, Unit IA1
- [14] DPM. 7 Steps in Privacy Risk Management. Data Priv Manag 2022. <https://dataprivacymanager.net/7-steps-and-elements-of-privacy-risk-management/> (accessed April 25, 2024).
- [15] Gérer le risque n.d. <https://www.infoentrepreneurs.org/en/guides/manage-risk/> (accessed April 21, 2024).
- [16] DPM. 7 Steps in Privacy Risk Management. Data Priv Manag 2022. <https://dataprivacymanager.net/7-steps-and-elements-of-privacy-risk-management/> (accessed May 28, 2024).
- [17] ISO/CEI Guide 51:1999(fr), Aspects liés à la sécurité — Principes directeurs pour les inclure dans les normes n.d. <https://www.iso.org/obp/ui/fr/#iso:std:iso-iec:guide:51:ed-2:v1:fr> (accessed May 27, 2024).
- [18] Villemeur A. Sûreté de fonctionnement des systèmes industriels: fiabilité, facteurs humains, informatisation. Eyrolles; 1988.
- [19] Rapport d'Etude 13\10\2006 Organisation internationale de normalisation. Rapport Omega 7-2
- [20] Development of a The BowTie Method. Site Saf Inc n.d. <https://sitesafety.ca/risk-management-solutions/the-bowtie-method/> (accessed June 13, 2024).
- [21] Energies | Free Full-Text | Classical Failure Modes and Effects Analysis in the Context of Smart Grid Cyber-Physical Systems n.d. <https://www.mdpi.com/1996-1073/13/5/1215#> (accessed June 13, 2024).
- [22] davidhoudusse. Quelles sécurités contre les chutes en hauteur ? - Pixela. Pixela Constr Haut Gamme En KIT 2021. <https://www.pixela.fr/quelles-securites-contre-les-chutes-en-hauteur/> (accessed June 13, 2024).
- [23] Lucky. Planning Lifting Operations. EntirelySafeCom 2022. <https://entirelysafe.com/planning-lifting-operations/> (accessed June 13, 2024).

- [24] Back to Basics: Confined Spaces. EHS Dly Advis 2022. <https://ehsdailyadvisor.blr.com/2022/09/back-to-basics-confined-spaces/> (accessed June 13, 2024).
- [25] Proper Lifting Techniques Diagram n.d. <https://mungfali.com/explore/Proper-Lifting-Techniques-Diagram> (accessed June 13, 2024).
- [26] Welder. Trade Manit n.d. <https://tradeupmanitoba.com/index.php/explore-careers/welder/> (accessed June 13, 2024).
- [27] Deluge System. Flamex Inc n.d. <https://www.sparkdetection.com/fire-protection/deluge-system/> (accessed June 12, 2024).
- [28] Comment utiliser un extincteur: 14 étapes (avec images). wikiHow n.d. <https://fr.wikihow.com/utiliser-un-extincteur> (accessed June 13, 2024).
- [29] SolarFire Systems. SolarFire Syst 2020. <https://solarfiresystems.com/news/what-are-fire-suppression-systems> (accessed June 12, 2024).
- [30] Importance of Electrical PPE for Work Safety. SafetyCulture 2023. <https://safetyculture.com/topics/ppe-safety/electrical-ppe/> (accessed June 13, 2024).
- [31] Explosive Material Hazard (ISO Triangle Hazard Symbol). InkAce n.d. <https://www.inkace.com/explosive-material-hazard-iso-symbol/> (accessed June 13, 2024).
- [32] Chemical Hazard Assessment and Prioritization - Toronto Metropolitan University n.d. <https://www.torontomu.ca/chemical-hazard-assessment-prioritization/> (accessed June 13, 2024).
- [33] FMECA | Failure Mode, Effects & Criticality Analysis | Quality-One 2018. <https://quality-one.com/fmeca/> (accessed June 4, 2024).